



# BALL BEARING UNITS

Housings		Case Iron Housings						Pressed Steel Plate Housings			
Bearings		P,P2M,PK,LP	PA,PG,PA2A	F,FX,FU FS	FL,FLU FLX,LF,FD	FC	T,ST	PP	PFL	PF	PFT
Setscrew Type	 UC2	UCP2 UCP2M UCPK2	UCPA2 UCPA2A UCPG2	UCF2 UCFU2	UCFL2 UCFLU2	UCFC2	UCT2 UCST2				
	C-1	B-2,B-3,B-10	B18-20	B-22,B-28	B-37,B-43	B-55	B-60,B-62				
	 UCX	UCPX		UCFX	UCFLX						
	C-3	B-12		B-27	B-40						
	 UC3	UCP3		UCF3 UCFS3	UCFL3		UCT3				
	C-4	B-13		B-31,B-34	B-46		B-61				
SB2,SB2G	 SB2,SB2G	SBP2G SBLP2G		SBF2G	SBFL2G SBLF2G SBFD2G			SBPP2	SBPFL2	SBPF2	SBPFT2
	C-13	B-8,B-16			B-42,B-49,B-51			B-21	B-54	B-58	B-59
Eccentric Locking Collar Type	 NA2	NAP2 NAP2M NAPK2		NAF2 NAFU2	NAFL2 NAFLU2	NAFC2	NAT2				
	C-5	B-4,B-5,B-11		B-23,B-29	B-38,B-44	B-56	B-63				
	 NA3	NAP3		NAF3 NAFS3	NAFL3		NAT3				
	C-6	B14		B-32,B-35	B-47		B-64				
SA2,SA2G	 SA2,SA2G	SAP2G SALP2G		SAF2G SAFU2G	SAFL2G SAFLU2G SALF2G SAFD2G			SAPP2	SAPFL2	SAPF2	SAPFT2
	C-12	B9,B-16		B-25,B-30	B-41,B-45,B-49,B-51			B-21	B-54	B-58	B-59
Adapter Type	 UK2	UK2P+H UKP2M+H		UKF2+H	UKFL2+H	UKFC2+H	UKT2+H				
	C-7	B6-7		B-24	B-39	B-57	B-65				
	 UK3	UKP3+H		UKF3+H UKFS3+H	UKFL3+H		UKT3+H				
C-8	B-15		B-33,B-36	B-48		B-66					

## Others

 UCPH2	 SALFTC2G SBLFTC2G	 SAPFTD2G SBPFTD2G	 SAFCT2G SBFCT2G	 UCC2 UCC3	 UCFB2	 UCFA2	 UCHA2	 Pressed Housing Agricultural Disk Bearings	Farm Implement Bearings		
B-17	B-50	B-52	B-53	B67-68	B-69	B-70	B-71	B-72		C-17,C-18,C-19	
 UC2T	 HC2	 RB2	 ER2 SER2	 ER2T	 GRA2 SA0	 CSB2	 CSA0 CSA2 RA2	 CS2 ORAE	 NAA3	Eccentric Locking Collar A200 A300	Adapter Steeve Locking H2300
C-2	C-5	C-1	C-9,C-11	C-10	C-14,C-15	C-13	C-12,C-14,C-15	C-16	C-15	C-20,C-21	C-22



## Contents

1. Features of TR Ball Bearing Units .....	A-2
2. Structure of Pillow Blocks .....	A-3
3. Types of Ball Bearing Units .....	A-4
4. Ball Bearing Inserts .....	A-7
4.1. Material of Bearing Rings and Balls .....	A-7
4.2. Bearing Tolerances .....	A-8
4.2.1 Outer Rings Tolerance .....	A-8
4.2.2 Inner Rings Tolerance .....	A-8
4.2.3 Tolerance for Distance "S" From Center Line of Outer Ring to Side of Inner Ring .....	A-9
4.3. Radial Internal Clearance of Bearings .....	A-10
5. Bearing Housings .....	A-11
5.1. Material for Cast Iron Housings .....	A-11
5.2. Tolerances for Housings .....	A-11
5.2.1. Tolerances for Housing Bores .....	A-11
5.2.2. Tolerances for Pillow Block Housings .....	A-11
5.2.3. Tolerances for Flange Type Housings .....	A-12
5.2.4. Tolerances for Cartridge Type Housings .....	A-14
5.2.5. Tolerances for Take-up Type Housings .....	A-14
5.3. Pressed Housings .....	A-15
5.3.1. Tolerances for Pressed Pillow Type Housings .....	A-15
5.3.2. Tolerances for Pressed Round and Oval Flange Type Housings .....	A-15
6. Selection of Ball Bearing Units .....	A-16
6.1. Basic Load Rating and Life .....	A-16
6.2. Bearings Selection According to Basic Dynamic Load Rating .....	A-17
6.2.1. Basic Rating Life .....	A-17
6.2.2. Anticipated Bearing Service Life .....	A-19
6.2.3. Calculation Method of Equivalent Dynamic Bearing Load P .....	A-19
6.3. Example of Bearing Size Selection .....	A-21
6.4. Adjusted Rating Life Equation .....	A-22
7. Lubrication and Operating Temperature .....	A-23
7.1. Lubricants .....	A-23
7.2. Operating Temperatures .....	A-23
7.3. Relubrication Period .....	A-23
7.4. Grease Fittings .....	A-25
8. Limiting Speed .....	A-26
9. Shafts Design .....	A-27
10. Mounting of Bearings on Shafts .....	A-29
10.1. Setscrews Locking Type Bearing .....	A-29
10.2. Adapter Sleeve Locking Type Bearings .....	A-30
10.3. Eccentric Locking Collar Type Bearings .....	A-30
10.4. Mounting Method of Housings .....	A-30
10.5. Mounting Method of Take-up Units .....	A-31
11. Bearing Inserts-Life Estimation for Different Speeds and Cr/Pr Ratios .....	A-32
Contents of Ball Bearing Units and Insert Bearings .....	B-1

## 1 .Features of TR Ball Bearing Units

Spherical outside surface ball bearing units consist of inserts and housings, based on the methods of mounting the units to shafts, they can be divided into three types: the setscrews type, the adapter sleeve locking type and the eccentric locking collar type.

The housings have two types: Grey or Ductile Cast iron housings and pressed steel plate housings.

Spherical outside surface self-aligning ball bearing units are compact in design with perfect sealing devices.

All TR ball bearing units have contact-type seals at both sides. The seals will vary according to the different types of bearings. By selecting the sealing devices, which is most suitable to the application condition, long bearing life can be guaranteed.

Sealing Devices:

Table 1.

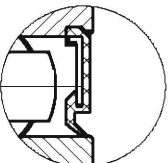
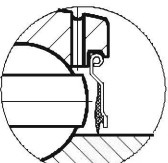
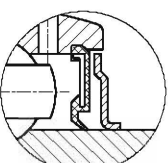
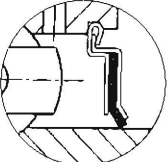
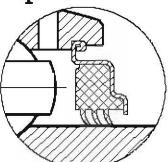

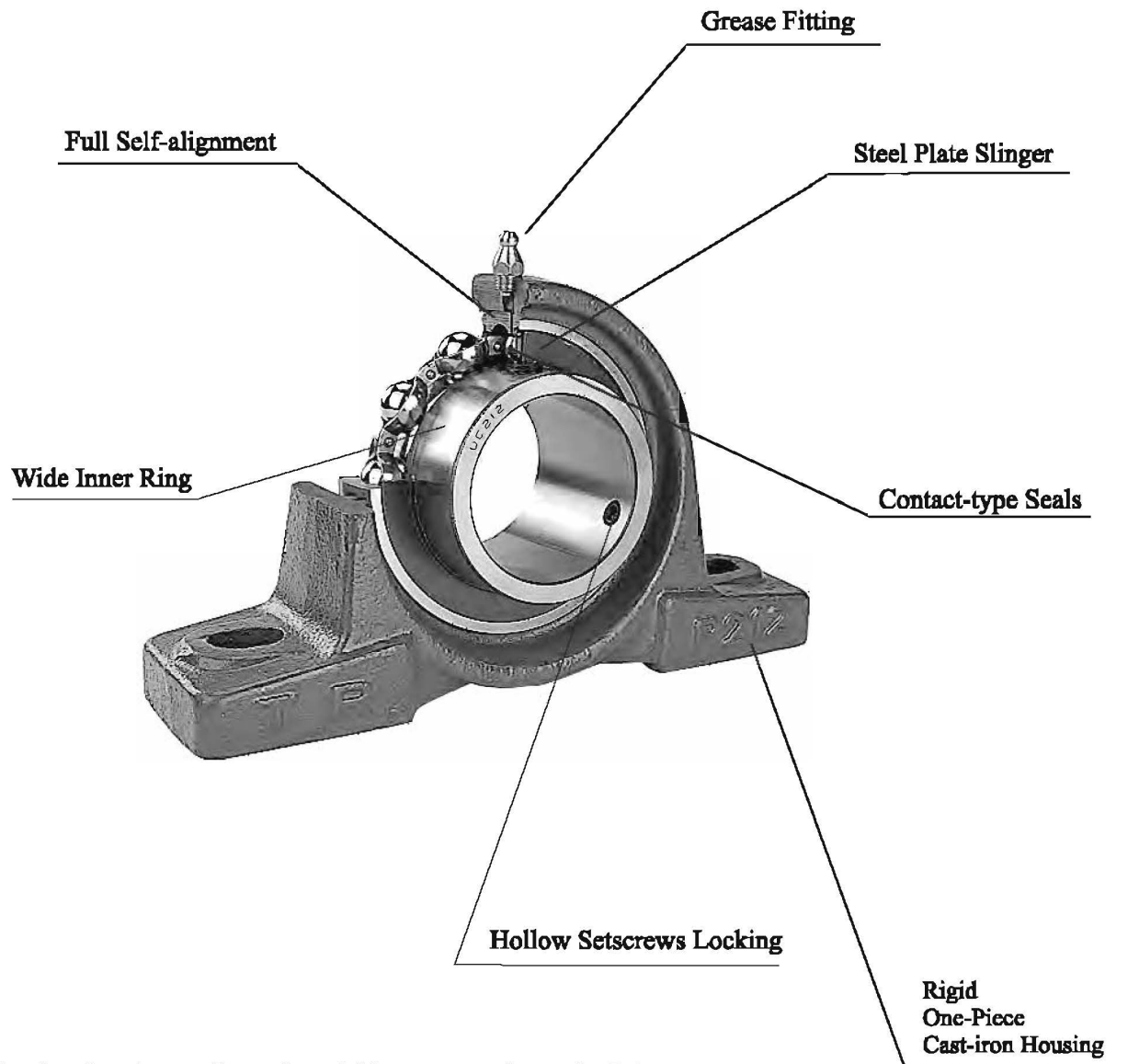

<p>Single-layer seal</p> 	<p>Synthetic rubber is baked to the core piece. It is inserted into the groove of the outer ring and then fitted on the inner ring outer diameter, thus it has low friction, high property in oil resistance and good mechanical stability.</p>
<p>Single-layer seal</p> 	<p>This consists of a pressed steel seal with a vulcanized synthetic rubber sealing lip baked inside. The seal forms a tiny clearance with the outer diameter of the inner ring, thus can provide efficient protection against the dust, sand or other contaminants.</p>
<p>Dual seals</p> 	<p>Oil seal is fixed in the outer ring inner diameter groove, and the slinger is set at the inner ring outer surface. In addition, the simultaneous revolution with inner ring generates the wind pressure for dust-proof property. This constitutes the ideal labyrinth, so effective dust-proof property can be guaranteed.</p>
<p>F Seal</p> 	<p>This type encloses a synthetic rubber washer between two metal caps. Due to the three pieces design with protective outer shroud ,the sealing is excellent.</p>
<p>Triple-lid seal</p> 	<p>This type consists of a metal cap and synthetic rubber seal, which are baked together to form a single seal. Seal lips have enough tightening allowance. In addition, the lip layers are of triple construction and outside matters, such as dust, water, etc., are shut out. This sealing system shows its outstanding function under bad conditions.</p>







## 2. Structure of Pillow Blocks







- Cast iron housing ... of one-piece rigid structure and easy for fixing.
- Wide inner ring ... for rigidity and more effective setscrews locking.
- Hollow setscrews ... two hollow setscrews 120° apart on the inner ring ensure easy and firm mounting on a shaft. Inner ring has been treated through special heat treatment.
- Steel plate slinger ... one on each side of the bearing by which dust can be efficiently excluded.
- Contact-type seals ... at both sides of bearing units.
- Grease fitting ... from which grease can be added .
- Full Self-alignment... when the bearing undergoes inevitable deformations or proper alignment can not be achieved during mounting.

### 3. Types of Ball Bearing Units:

	<p><b>1. Pillow blocks</b></p> <p>UCP2,NAP2,UKP2+H,SBP2G,SAP2G UCP2M,NAP2M,UKP2M+H UCPK2,NAPK2 UCPX,SALP2G,SBLP2G UCP3,NAP3,UKP3+H</p> <p>There are various series of pillow blocks:P200, P200M, P300, PK200, PX00, LP200</p> <p>They can be mounted with different kinds of bearings, making them the most extensively used among ball bearing units.</p>
	<p><b>2. High center height pillow blocks</b></p> <p>UCPH2,NAPH2,UKPH2+H</p> <p>It is one type of pillow blocks with a higher center height.</p>
	<p><b>3 Tapped-base pillow blocks</b></p> <p>UCPA2,NAPA2,UKPA2+H UCPA2A UCPG2</p> <p>It has compact structure, saving mounting space. It can be fitted with bolts from the underneath of the base.</p>
	<p><b>4. Square flange units</b></p> <p>UCF2, NAF2, NKF2+H, SAF2G UCFX, SBF2G, UCFU2, NAFU2, SAPU2G UCF3, NAF3, UKF3+H</p> <p>These bearing units are designed to fix at the sides of the machine which are vertical to the center of the shafts by means of 4 bolts. The mounting method is widely used in the machines. The setscrews, the eccentric locking collar and the adaptor sleeve bearings have the same mounting method as the P housings do.</p> <p>Series:F200,FX00,FU200 Square flange cartridge units</p> <p>UCFS3, NAFS3, UKFS3+H</p> <p>These bearing units are installed in the holes on the side of the places where concentricity is demanded</p>
	<p><b>5. Round flanged cartridge units</b></p> <p>UCFC2,NAFC2,UKFC2+H</p> <p>These bearing units are installed in the holes on the side of the places where <b>concentricity</b> is demanded.</p>

	<p>6. Oval flange units      UCFL2,NAFL2,UCFLX,SAFL2G,UCFLU2,NAFLU2 SAFLU2G,UKFL2+H,SBFL2G UCFL3,NAFL3,UKFL3+H</p> <p>Series: FL200, FL300, FLU200, FLX00</p>
	<p>7. LF,LFTC,FD,PFTD and PFTD-G type two-bolt flange units are for use with SB (or SB-G) and SA (or SA-G) type inserts only</p> <p>SALF2G,SBLF2G,SALFTC2G,SBLFTC2G SAFD2G,SBFD2G SAPFTD2,SBPFTD2,or SAPFTD2G,SBPFTD2G SAFCT2,SBFCT2,or SAFCT2G,SBFCT2G</p> <p>LF,LFTC,FD      Material:      Bolt PFTD,FCT      Grey iron      Configuration:                       Ductile iron      Round hole     Square hole</p>
	<p>8. Flange bracket units      UCFB2</p> <p>This type has three set holes on only one side of the flange. This type of bearing unit is used where the mounting space is limited, and the housing can be fixed on only one side.</p>
	<p>9. Adjustable flange units      UCFA2</p> <p>This type has a two-bolt base with one side adjustable, enabling distance from center of shaft to be varied</p>
	<p>10. Take up units      UCT2,NAT2 UCST2 UCT3,NAT3</p> <p>It can slide on a fixed track, enabling free alignment of the center of the shaft. With different grooves, there are two series: T200, ST200.</p>
	<p>11. Circular flange units      UCC2 UCC3</p> <p>This type has a cylinder surface that meets tolerance demands. It can be used for non-bearing orientational support or central positioning for long shafts.</p>
	<p>12. Hanging flange units      UCHA2</p> <p>This type is applied to conveying machines connected by pipe threads.</p>

	<p><b>13.Pressed housing pillow blocks</b></p> <p style="text-align: right;"><b>SAPP2, SBPP2</b></p> <p>Pressed housings are with light weight and simple structure and consists of two pieces of pressed steel plates. This type is applied to the machine whose rotating speed is lower or medium, or the machine with light load. The inserts for the pressed housings are usually SA or SB series.</p>
	<p><b>14.Pressed housing round flange units</b></p> <p style="text-align: right;"><b>SAPF2, SBPF2</b></p> <p>This type consists of two pieces of pressed steel plates, mounted with SA2 or SB2. It has light weight and simple structure, which is applied to the machine of which the rotating speed is low or medium, or the machine load is light .</p>
	<p><b>15.Pressed housing flange units</b></p> <p style="text-align: right;"><b>SAPFT2, SBPFT2</b></p> <p>This type has the same function as the pressed round flange housing. It can be used where the mounting space is limited, because it takes smaller space.</p>
	<p><b>16.Pressed housing oval flange units</b></p> <p style="text-align: right;"><b>SAPFL2, SBPFL2</b></p> <p>This type has only two bolt holes. It needs much smaller mounting space. Its function is the same as the above-mentioned pressed flange housings.</p>
	<p><b>17.Pressed housing agricultural disk bearings</b></p> <p style="text-align: right;"> <b>ST491A,ST491B,DHU45R-209,ST209-1 <math>\frac{1}{8}</math></b>  <b>DHU55R-211,DHU40S-211,FD211-1 <math>\frac{1}{2}</math></b>  <b>ST211-1 <math>\frac{3}{4}</math></b>  <b>ST211-2 <math>\frac{3}{16}</math></b> </p> <p>This type consists of a housing made of high-quality carbon structural steel plates through pressing, and an agricultural disk bearing with triple seals. It can be used under adverse circumstances. It can be relubricated through the grease nipple.</p>

4. Ball Bearing Inserts

The spherical outside ball bearing inserts are sealed at both sides. The internal structure dimensions, chromium bearing steel balls and retainers are same as those of the deep groove ball bearings.

4.1 Material of Bearing Rings and Balls.

The bearing rings and balls are made of GCr15 chromium bearing steel of which the chemical composition are shown in table 2.

Table 2. (%)

C	Cr	Si	Mn	S	P
0.95-1.05	1.30-1.65	0.15-0.35	0.20-0.40	≤0.020	≤0.027

The hardness of the bearing ring is 59HRC~64HRC, of the ball is 61HRC~66HRC, with high wear resistance and contact fatigue strength.

The inner rings of setscrew type bearings(US,RB,SB,CSB,ER,SER series)are special heat treated .Therefore,the raceway of the inner ring is hardened completely through the ring,while the setscrews hole zone on the extended ends of the inner rings are softened ,so that the setscrew hole zone would not break under high torque.

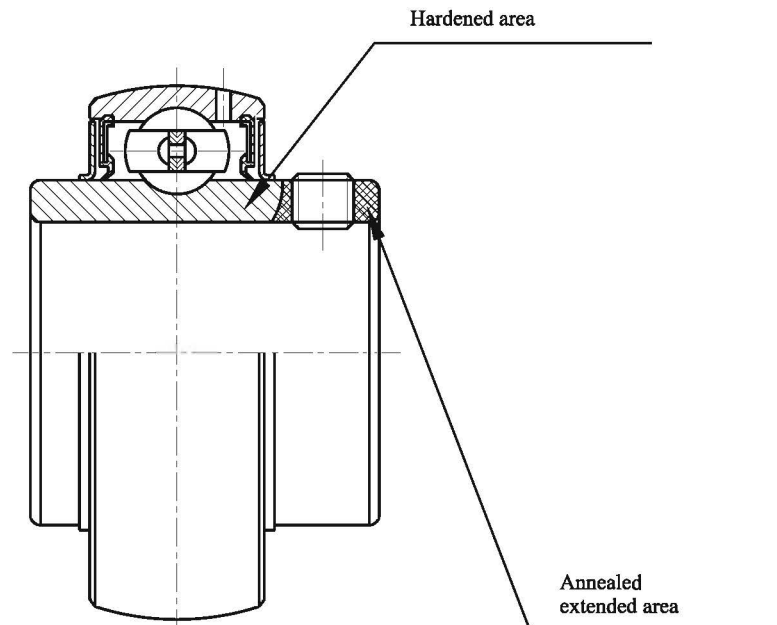



## 4.2 Bearings Tolerances

### 4.2.1 Outer Rings Tolerances

The outer rings tolerances, which are shown in Table 3 , are the same as those for deep groove bearings.

**Table 3. Outer rings tolerances (  $\mu\text{m}$  )**

D ( mm )		$\Delta D_{mp}$		$K_{ca}$
over	incl.	high	low	max.
30	50	0	-11	20
50	80	0	-13	25
80	120	0	-15	35
120	150	0	-18	40
150	180	0	-25	45
180	250	0	-30	50

Notes: (1)  $\Delta D_{mp}$  = the deviation of a single plane mean

outside diameter of the outer ring.

(2)  $K_{ca}$  = Radial runout of assembled bearing outer ring.

(3) D = Nominal outer ring outside diameter.

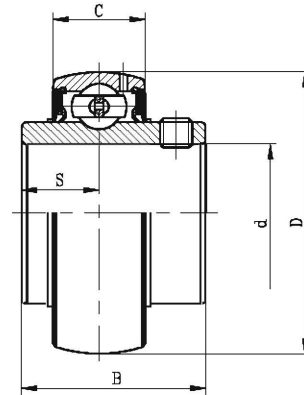

### 4.2.2 Inner Rings Tolerances

The inner rings tolerances are different from those of deep groove bearings. The values are shown in Table 4 and Table 5.

#### 1) Tolerances for cylindrical bore bearing inner rings

**Table 4. Cylindrical bore inner rings tolerances (  $\mu\text{m}$  )**

d (mm)		$\Delta d_{mp}$		$K_{ia}$	$\Delta B_s$	
over	incl.	high	low	max.	high	low
10	18	+18	0	12	0	-120
18	30	+21	0	15	0	-120
30	50	+25	0	18	0	-120
50	80	+30	0	22	0	-150
80	120	+35	0	28	0	-200
120	180	+40	0	35	0	-250

Notes: (1) d = Nominal bore diameter

(2)  $\Delta d_{mp}$  = The deviation of a single plane mean bore diameter of the inner rings

(3)  $K_{ia}$  = Radial runout of assembled bearing inner ring

(4)  $\Delta B_s$  = The deviation of a single width of inner ring

**2) Tapered Bore Inner Rings Tolerances**
**Table 5. Tolerances on inner rings of tapered bore bearings (μm)**

d (mm)		Δ dmp		Δ d <sub>imp</sub> - Δ dmp	
>	≤	high	low	max.	min.
18	30	+33	0	+21	0
30	50	+39	0	+25	0
50	80	+46	0	+30	0
80	120	+54	0	+35	0
120	180	+63	0	+40	0

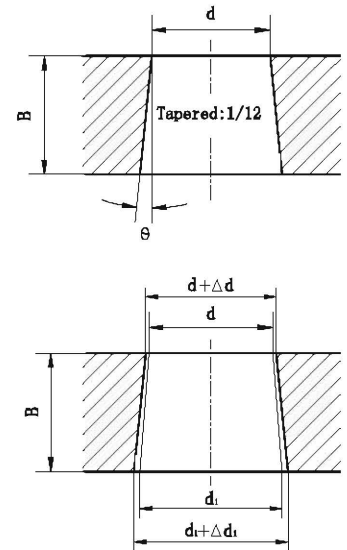

Notes: (1) d = Nominal bore diameter

(2) d<sub>1</sub> = Theoretical diameter of larger end of tapered bore

d<sub>1</sub> is obtained by following formula:

$$d_1 = d + 0.083333 B$$

(3) B = Nominal inner ring width

(4) θ = The nominal taper angle = 2° 23' 9.4" = 2.38594°

(5) Δ d<sub>mp</sub> = Single plane mean bore diameter deviation

in theoretical diameter of smaller end of bore

(6) Δ d<sub>imp</sub> = Single plane mean bore diameter deviation in

theoretical diameter of larger end of bore

**4.2.3 Tolerances for Distance "S" From Center Line of Outer Ring to Side of Inner Ring**

Tolerances for distance "S" between the radial plane passing through center of spherical surface of outer ring and a side of inner ring are shown in table 6.

**Table 6. (μm)**

Nominal bore diameter d(mm)		Deviation ΔS
>	≤	
10	50	± 200
50	80	± 250
80	120	± 300
120	180	± 350

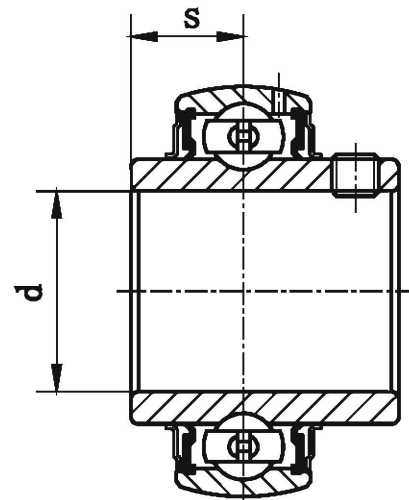

### 4.3 Radial Internal Clearance of Bearings

The radial internal clearance for the spherical outside surface ball bearings is usually greater than that of the same sizes of deep groove ball bearings. The clearance for the cylindrical bore bearings is shown in Table 7, (basic group which is equivalent to ISO9628:1992.) While the clearance for the taper bore bearings is shown in Table 8.

**Table 7. Radial internal clearance of cylindrical bore bearings** ( $\mu\text{m}$ )

Nominal bore diameter d (mm)		Clearance (with setscrews or eccentric locking collars)					
		Group 2		Basic group		Group 3	
>	$\leq$	min.	max.	min.	max.	min.	max.
10	18	3	18	10	25	18	33
18	24	5	20	12	28	20	36
24	30	5	20	12	28	23	41
30	40	6	20	13	33	28	46
40	50	6	23	14	36	30	51
50	65	8	28	18	43	38	61
65	80	10	30	20	51	46	71
80	100	12	36	24	58	53	84
100	120	15	41	28	66	61	97
120	140	18	48	33	81	71	114

**Table 8. Radial internal clearance of tapered bore bearings** ( $\mu\text{m}$ )

Nominal bore diameter d (mm)		Clearance with tapered bore (UK200, UK300)					
		Group 2		Basic group		Group 3	
>	$\leq$	min.	max.	min.	max.	min.	max.
10	18	10	25	18	33	25	45
18	24	12	28	20	36	28	48
24	30	12	28	23	41	30	53
30	40	13	33	28	46	40	64
40	50	14	36	30	51	45	73
50	65	18	43	38	61	55	90
65	80	20	51	46	71	65	105
80	100	24	58	53	84	75	120
100	120	28	66	61	97	90	140
120	140	33	81	71	<b>114</b>	105	160

Notes: When the internal clearance of a bearing is measured, deformation occurs under loading. Therefore, to obtain the measuring value clearance, add the below correction clearance to the radial clearance above.

**Table 9.**

Bore dia. d (mm)		Measuring load (N)	Radial clearance correction amount ( $\mu\text{m}$ )		
>	<		C <sub>2</sub>	Normal	C <sub>3</sub>
10	18	25	4	4	5
18	30	50	5	5	6
30	50	50	4	4	5
50	80	100	6	7	7
80	100	150	8	8	9

## 5. Bearing Housings

### 5.1 Material for Cast Iron Housings

The material for cast iron housings are HT200(grey cast iron) and QT450-10(ductile cast iron). Ductile cast iron housings are only applied to PFTD2 and FCT2 series. The material for pressed housings is 08 or 10 cold-rolled steel plate.

### 5.2. Tolerances for Housings

#### 5.2.1 Tolerances for Housing Bores

Table 10.

Nominal bore diameter Da(mm)		Deviation of bore diameter $\Delta D_{am}$					
		Tolerance range level H7		Tolerance range level J7		Tolerance range level K7	
>	$\leq$	high	low	high	low	high	low
30	50	+25	0	+14	-11	+7	-18
50	80	+30	0	+18	-12	+9	-21
80	120	+35	0	+22	-13	--	--
120	180	+40	0	+26	-14	--	--
180	250	+46	0	+30	-16	--	--
250	315	+52	0	+36	-16	--	--

Notes: For TR standard products 201 to 209, X05 to X08, 305 to 309 and 321 to 328 please refer to level H7. 210 to 220, X09 to X20 and 310 to 320 please refer to level J7.

#### 5.2.2 Tolerances for Pillow Block Housings

Tolerances for pillow block housings are shown in Table 11.

Table 11.

Housings No. P, PK, AK, LP, PH, PA, PA2A, PG	Deviations $\Delta H$	(mm)	
		Housings No.	Deviations $\Delta H$
P203-210, PX05-X09, P305-310, P204M-210M PK203-210, LP201-208, PH203-210 PK203-210, LP204A-210A, PG204-208	$\pm 0.15$	PA203-210 PA204A-210A PG204-208	$\pm 0.70$
P211-218, PX10-X18, P311-319, P211M-214M PK211-213, PH211-215, PA211-213	$\pm 0.20$	PA211-213	$\pm 1.00$
P220, PX20, P320-328	$\pm 0.30$		

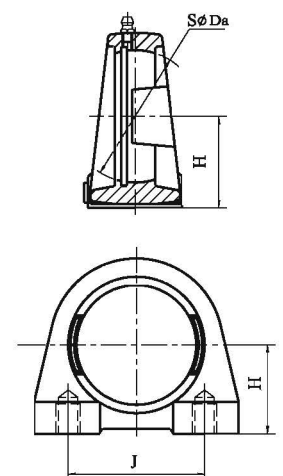

5.2.3 Tolerances for Flange Type Housings are shown in Table 12.

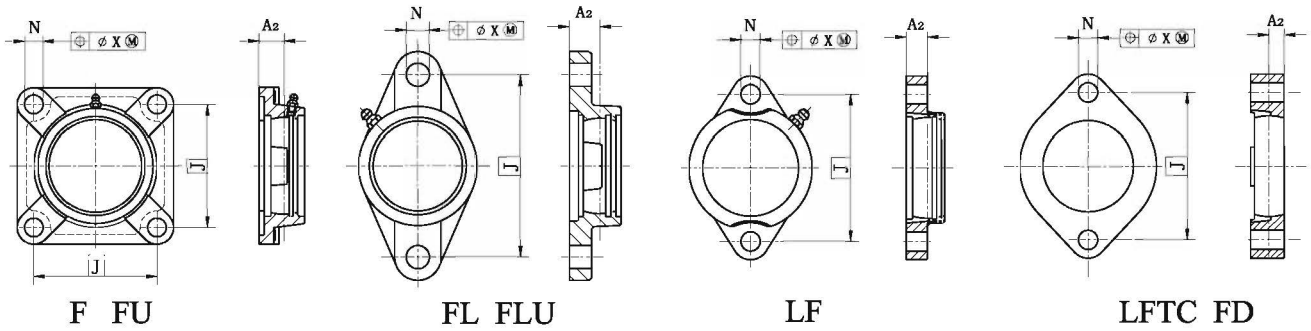

Table 12.

(mm)

Housings No.							Deviations $\Delta A_2$		Tolerances of position for mounting bolt holes
F, FU	F, FL	FL,FLU	FX,FLX	LF	LFTC	FD	high	low	$X \leq$
---	---	---	---	203	---	---			
204	---	204	---	204	20	204			
205	305	205	X05	205	25	205			
206	306	206	X06	206	30	206	+0.5	-0.5	0.7
207	307	207	X07	207	35	207			
208	308	208	X08	---	40	---			
209	309	209	X09						
210	310	210	X10						
211	311	211	X11						
212	312	212	X12						
213	313	213	X13						
214	314	214	X14						
215	315	215	X15						
216	316	216	X16						
217	317	217	X17				+0.80	-0.80	1.0
218	318	218	X18						
--	319	--	--						
	320		X20						
	322								
	324								
	326								
	328								

PFTD,FCT

\*Re-lub. Type PFTD,FCT Housings

Available too.

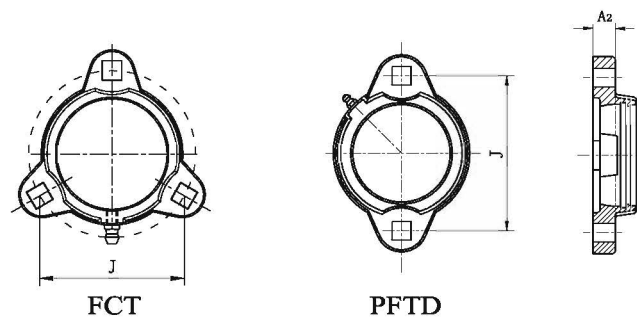

Table 13.

(mm)

PFTD203~PFTD207 FCT203~FCT207	$+0.50 \geq \Delta A_2 \geq -0.50$	$+1.0 \geq \Delta J \geq -1.0$
----------------------------------	------------------------------------	--------------------------------

Tolerances for round flange type housings are shown in Table 14.

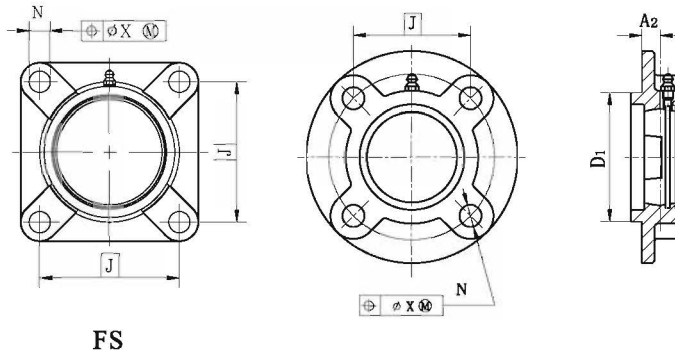

Table 14. (mm)

Housings No.	Deviation $\Delta A_2$		Deviation $\Delta D_1$		Radial runout of spigot joint	Tolerance of position for mounting bolt holes X
	high	low	high	low	max	max
FC203-FC206 FS305	+0.50	-0.50	0	-0.046	0.2	0.7
FC207-FC210 FS306-FS308			0	-0.054		
FS309-FS310			0	-0.063		
FC211-FC217 FS311-FS313	+0.80	-0.80	0	-0.072	0.3	1.0
FC218 FS314-FS318			0	-0.081	0.4	
FS320-FS322			0	-0.089		
FS324-FS328			0	-0.089		

Tolerances for special type flange units are shown in Table 15.

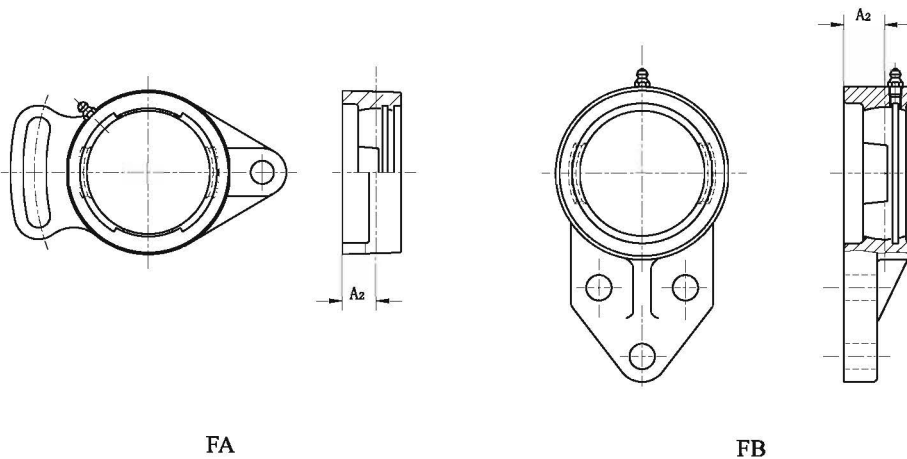

Table 15. (mm)

Housings No.		Deviation $\Delta A_2$	
		high	low
FA203-FA210	FB203-FB210	+0.50	-0.50
FA211-FA213	FB211-FB213	+0.80	-0.80

**5.2.4 Tolerances for Cartridge Type Housings**

Tolerances for Cartridge type housings are shown in Table 16.

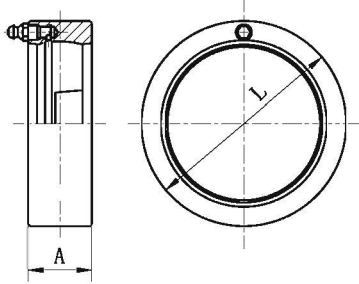

Table 16.

(um)

Hosing No	Deviation of outside diameter $\Delta L$		Radial runout of spjgot joint max.	Deviation $\Delta A$	
	C2 series(Hs)	C3 series(Hs)		high	low
	high	low			
C203-C205	0	-0.030	0.2	+0.2	-0.2
C206-C210 C305-C308	0	-0.035			
C309-C310	0	-0.040	0.3	+0.25	-0.25
C211-C216 C311-C314					
C315-C318	0	-0.046			
C319	0	-0.052	0.4	+0.3	-0.3
C320-C322	0	-0.057			
C324-C328	0	-0.057			

**5.2.5 Tolerances for Take-up Type Housings**

Tolerances for Take-up type housings are shown in Table 17.

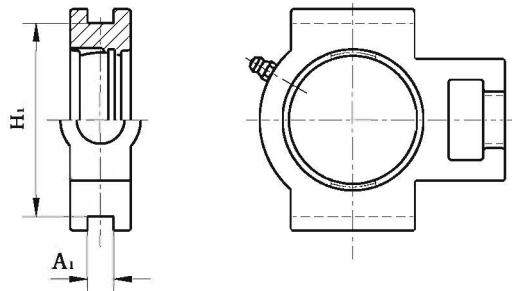

Table 17.

(mm)

Hosing No	Deviations $\Delta A1$		Deviations $\Delta H1$		Parallelism of H1 sliding slot max.
	high	low	high	low	
T203-T210 T305-T310	+0.2	0	0	-0.5	0.5
T211-T218 T311-T318	+0.3	0	0	-0.8	0.6
T319-T322	+0.3	0	0	-0.8	0.7
T324-T328	+0.3	0	0	-0.8	0.8
ST204-ST210	+0.5	-0.25	+0.25	-0.25	0.5
ST211-ST212	+1.0	-0.25	+0.4	-0.4	0.6

### 5.3. Pressed Housings.

#### 5.3.1. Tolerances for Pressed Pillow Type Housings.

Table 18. (mm)

Housings No.	Deviation of mounting bolt hole diameter $\Delta N$	
	high	low
PP203-PP207	+0.25	-0.25

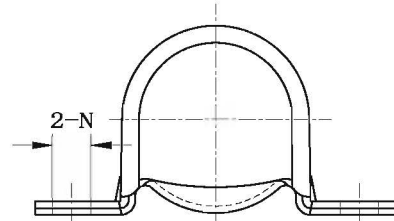

#### 5.3.2 .Tolerances for Pressed Round and Oval Flange Type Housings.

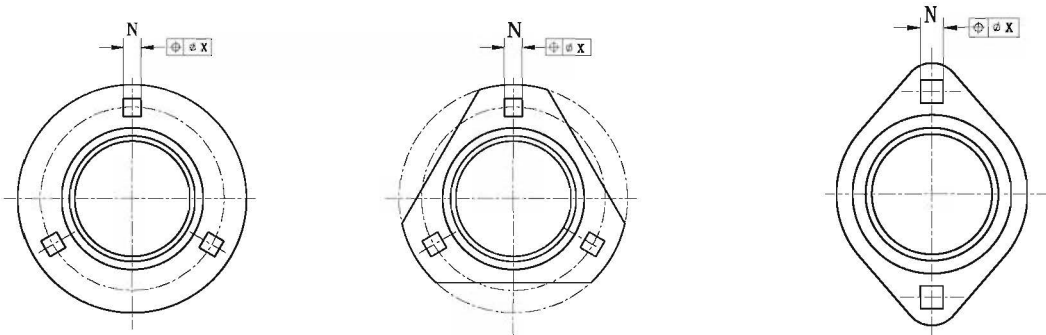

Table 19. (mm)

Housings No.	Deviation of length of square for mounting bolt hole $\Delta N$		Tolerances of position for mounting bolt holes X
	high	low	
PF203~PF208 PFT203~PFT208 PFL203~PFL208	+0.25	-0.25	0.4



## 6. Selection of Ball Bearing Units

The bearing size is usually selected according to the load applied to the bearing, the required bearing life and reliability. As a technical index of the bearing capacity, there are two types of basic load rating: basic dynamic load rating and basic static load rating.

The load applied to the bearing when operating under rapid rotation ( $n > 10r/\text{min}$ ) is defined as basic dynamic load rating  $C$ , while the load applied to the bearing when operating under static circumstances, slow rotation or oscillation ( $n \leq 10n/\text{min}$ ) is defined as basic static load rating  $C_0$ .

Ball bearings are classified as concentric bearings because they mainly bear radial force. Therefore, the load applied to the bearing is called radial basic dynamic load rating  $C_r$ , or radial basic static load rating  $C_{0r}$ .

The above two load ratings  $C_r$  and  $C_{0r}$  are shown in the bearing tables (page C-1~C-19).

Normally, the life of a rolling bearing is an important element of selecting bearings. Here the usually said bearing life refers to the bearing fatigue life. If the bearing operates properly (with suitable load, correct mounting and fine lubrication), the main damage would be fatigue flaking due to the repeating action of variable load charged on the contact area, which is inevitable. However, with different applications and demands, damages can also come from increasing noise and vibration, inaccuracy caused by abrasion, and lubricating grease aging after some time's operation. The bearing will be disabled or fail to meet a specific kind of mechanical demand under such damages. The life before disability is defined respectively as noise life, abrasion life, and lubricating grease life.

Beside the above lives, the bearing can also be disabled by sintering, breakage or cracking, sealing failure, etc. These should be defined as bearing failure. It can be caused by inappropriate choice of bearings, faulty design, mounting, operation and maintenance, which should be distinguished from the bearing life.

### 6.1 Basic Load Rating and Life

**Basic dynamic load rating:** The basic dynamic load rating is defined as the constant load applied to a bearings with stationary outer rings that the inner rings can endure for a rating life of one million revolutions ( $10^6$  rev.).

**Life:** The life of a rolling bearing is defined as the total number of revolutions which the bearing is capable of enduring before the first evidence of fatigue flaking develops on any one of the rings or rolling elements.

**Reliability :** The reliability is the percentage of the bearing of a group of apparently identical bearings operating under identical conditions which can expect to attain or exceed a certain defined life. The reliability of an individual bearing is the probability of the bearing to attain or exceed a defined life.

**Basic rating life  $L_{10}$  :** For a group of apparently identical rolling bearings operating under identical conditions, the basic rating life is defined as the total number of revolutions that 90% of the bearings can be expected to complete or exceed.

The basic rating life  $L_{10}$  estimation for ball bearings with different speeds and  $\frac{C_r}{P_r}$  ratios is shown in page A-32.

## 6.2 Bearings Selection According to Basic Dynamic Load Rating

### 6.2.1 Basic Rating Life

The fatigue rating of deep groove ball bearings is calculated by following formula:

$$L_{10} = \left( \frac{C}{P} \right)^3$$

$$\text{or } \frac{C}{P} = L_{10}^{1/3}$$

Where  $L_{10}$  = basic rating life ( $10^6$  r )

$C$  = basic dynamic load rating (N)

$P$  = equivalent dynamic bearing load (N)

The basic dynamic load rating  $C$  is a hypothetical constant load with a fixed direction under which the bearing can attain a basic rating life of one million revolutions. For radial bearing, the load refers to the radial load.

The equivalent dynamic bearing load  $P$  is a constant load with a fixed direction under which the bearing life is identical to that of the bearing operating under actual load.

For a bearing operating with a constant rotation speed ,  
the basic rating life can be expressed in terms of operating hours:

$$L_{10h} = \frac{10^6}{60n} \left( \frac{C}{P} \right)^3$$

OR

$$L_{10h} = \frac{10^6}{60n} L_{10}$$

$$\frac{16666}{n} \left( \frac{C}{P} \right)^3$$

Where  $L_{10h}$  = basic rating life (h)

$n$  = bearing operating speed of rotation (r/min)

For easier calculation, 500 hours as base of rating life is taken,  
and the speed factor  $f_n$  and the life factor  $f_h$  is introduced :

$$f_n = \left( \frac{33\frac{1}{3}}{n} \right)^{1/3}$$

$$f_h = \left( \frac{L_{10h}}{500} \right)^{1/3}$$

In this way, the formula is simplified to

$$C = \frac{f_h}{f_n} P$$

The values of  $f_n$  and  $f_h$  can be found in Fig.1 by referring to the operation speed  $n$  and the anticipated bearing service life  $L_{10h}$ . Then, with the radial load (or the equivalent dynamic bearing load ), the basic dynamic load rating can be determined. By this way, the bearing size can be determined according to the basic dynamic load rating value in the bearings Table.(Please refer to page C-1~C-19).

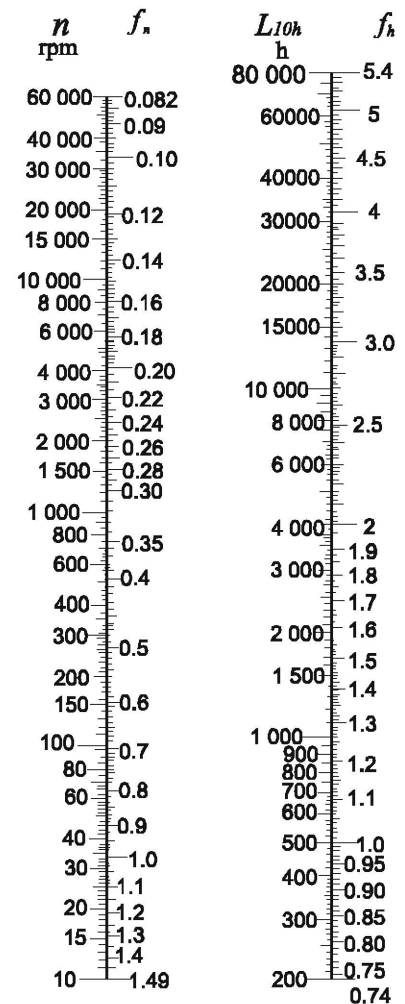

Fig.1

If the bearing operates under indeterminate loads and rotation speed, the following formula should be applied when calculating the bearing life:

$$P_m = \sqrt[3]{\frac{1}{N} \int_0^N P^3 dN}$$

Where  $P_m$  = mean equivalent dynamic bearing load (N)

$P$  = equivalent dynamic bearing load (N)

$N$  = total revolution numbers within one load changing cycle ( r )

### 6.2.2 Anticipated Bearing Service Life

When selecting a bearing, one should usually predetermine an appropriate service life according to the relevant machine type, operating conditions and reliability requirement. Generally speaking, the anticipated bearing service life can be determined by referring to the maintenance period of a machine.

### 6.2.3 Calculation Method of Equivalent Dynamic Bearing Load P

The basic equivalent dynamic bearing load is determined under a hypothetical condition. When calculating the bearing life, the actual load has to be converted into equivalent dynamic bearing load which is in conformity with the load condition determining the equivalent dynamic load rating.

General equation for calculating the equivalent dynamic bearing load:

$$P = X F_r + Y F_a$$

Where:  $P$  = equivalent dynamic bearing load (N)

$F_r$  = actual radial load (N)

$F_a$  = actual axial load (N)

$X$  = radial factor

$Y$  = thrust factor

The values of X and Y are determined by the ratio between the applied axial load  $F_a$  and the basic static load rating  $C_0$ . The axial load which the spherical outside surface bearings can carry is determined by the mounting method of the bearings on the shafts.

For the setscrews locking type or eccentric locking collar type bearings, if flexible shafts are applied and the setscrews are tightened enough (See Table 34 for reference torque), the axial load  $F_a$  which the bearing can carry must not surpass 20% of the radial load  $F_r$ .

For the adapter sleeve locking type bearing, if the nuts are properly tightened, the axial load  $F_a$  can be maximum 15% to 20% of the radial load.

The values of radial and thrust factors X and Y for spherical outside surface ball bearings can be obtained from the following table:

Table 20.

$\frac{F_a}{C_0}$	$\frac{F_a}{F_r} \leq e$ $p = F_r$		Clearance for group 2			Clearance for normal group			Clearance for group 3		
			$\frac{F_a}{F_r} > e$		e	$\frac{F_a}{F_r} > e$		e	$\frac{F_a}{F_r} > e$		e
	X	Y	X	Y		X	Y		X	Y	
0.025	1	0	0.56	2.0	0.22	0.46	1.75	0.31	0.44	1.42	0.4
0.04	1	0	0.56	1.8	0.24	0.46	0.62	0.33	0.44	1.36	0.42
0.07	1	0	0.56	1.6	0.27	0.46	1.46	0.36	0.44	1.27	0.44
0.13	1	0	0.56	1.4	0.31	0.46	1.30	0.41	0.44	1.16	0.48
0.25	1	0	0.56	1.2	0.37	0.46	1.14	0.46	0.44	1.05	0.53
0.5	1	0	0.56	1	0.44	0.46	1	0.54	0.44	1	0.56

When twist load is applied to the bearings, the equivalent dynamic bearing load is calculated by:

$$P_m = f_m \cdot P$$

Where  $P_m$  = equivalent dynamic bearing load when considering twist load

$f_m$  = twist load factor, which is defined as follows:

when the twist load is small:  $f_m = 1.5$

when the twist load is big:  $f_m = 2$

When shocking load is applied to the bearings, the equivalent dynamic bearing load can be calculated by the following equation:

$$P_d = f_d \cdot P$$

Where  $P_d$  = equivalent dynamic bearing load when considering shocking load

$f_d$  = shocking load factor, which is defined as follows:

When no shocking load or minor shocking load is applied:

$$f_d = 1 \sim 1.2$$

When adequate shocking load is applied:

$$f_d = 1.2 \sim 1.8$$

### 6.3 Example of Bearing Size Selection

One ball bearing is to operate at a rotation speed of 1000 r/min under only a radial load of  $F_r = 3000$  N, with a basic rating life of at least 20000 hours, select the bearing size.

From the required rotation speed, it can be found that:

$$f_n = 0.322 \text{ ( Fig 1. shows about 0.32 )}$$

From the required basic rating life (anticipated service life), at least 20000 hours, it can be found that:

$$f_h = 3.42 \text{ (Fig 1. shows about 3.4)}$$

Under only a radial load, i.e.,

$$P = F_r = 3000 \text{ (N)}$$

Therefore,

$$C = \frac{f_h}{f_n} P = \frac{3.42}{0.322} \times 3000 = 31863 \text{ (N)}$$

A simplified way to calculate the bearing life can be applied by using Fig 2.

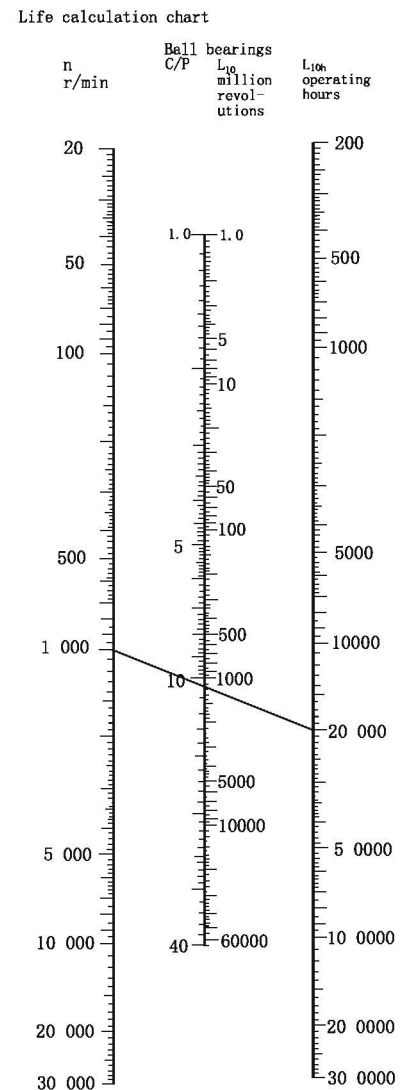

Fig.2

By connecting  $n(1000r/min)$  and the required basic rating life  $L_{10h}$  (20000 hours) with a straight line, it can be found that  $C/P$  value is 10.6, As is known,  $P = F_r = 3000 \text{ N}$ , thus the required basic dynamic load rating is:

$$\begin{aligned} \frac{C}{P} &= 10.6 \\ C &= 10.6P \\ &= 10.6 \times 3000 = 31800 \text{ (N)} \end{aligned}$$

In this way, we can select the bearing from the bearing table. (Please refer to page C-1 ~ C-19)

#### 6.4 Adjusted Rating Life Equation

The basic rating life  $L_{10}$  calculated with the bearing life calculation formula can be applied to calculate the rating life of bearings made of ordinary bearings steel ( i.e., bearing life with reliability of 90%.)

But some occasions may require a more accurate and reliable life calculation, taking the bearing's quality and operating conditions into consideration. In this case, the adjusted rating life  $L_{nm}$  can be applied.

The adjusted rating life  $L_{nm}$  equation is as follows:

$$L_{nm} = a_1 a_{iso} L_{10}$$

Life adjustment factor for reliability  $a_1$  is shown in Table 21.

Table 21.

Reliability	$L_{nm}$	$A_1$
90	$L_{10m}$	1
95	$L_{5m}$	0.64
96	$L_{4m}$	0.55
97	$L_{3m}$	0.47
98	$L_{2m}$	0.37
99	$L_{1m}$	0.25

Life adjustment factor for system approaches  $a_{iso}$  is defined by the following factors:

- Material (such as cleanliness, hardness, surface structure, fatigue limit, temperature response);
- Lubrication (such as viscosity, bearing rotation, bearing size, type of lubricant, additive);
- Environment (such as pollution level, humidity);
- Impurity (such as hardness, size, shape, material);
- Internal stress in the ring (during production or ring interference after mounting);
- Mounting (such as assembling and disassembling damage, non-concentricity);
- Bearing load.

It means that any changes of the above factors will affect the bearing life directly. So when selecting bearings, all kinds of factors should be taken into consideration to calculate a proper factor, so that the chosen bearing can fulfill an expected need.

## 7. Lubrication and Operating Temperature

### 7.1 Lubricants

The bearings are filled with the lubricating grease (lithium grease NO.2) that is used in large-medium size of motor bearings. Its physical and chemical properties are shown in Table 22.

Table 22.

Density (1/10mm)	Without operation	265~295
Dropping point ( °C )		≥175
Mechanical impurities (pc/cm <sup>3</sup> )	10-25 μ m 25-75 μ m 25~125 μ m above 125 μ m	Within 5000 Within 3000 Within 500 0

### 7.2 Operating Temperature.

The bearings usually operate below the temperature of 120°C (the measuring temperature of the outer ring is 100°C ). Grease life reduction has to be taken into account when the bearings continue to operate at a temperature above 70°C.

The lowest operating temperature should not be lower than -20°C.

For higher or lower temperature application, please consult us for further information.

### 7.3 Relubricate Period

Under normal operating condition, the grease should conform to the life of the bearings. Relubricatable type bearing units must be periodically greased to assure long life.

The greasing interval is dependent on the bearing running speed, operating temperatures and ambient conditions.

The following table shows the standard relubrication period.(Table 23)

Table 23.

dn Value	Cleanliness	Temperature		Greasing interval
		°C	°F	
40,000 and below	Clean	-15~65 Up to 65~100	+5~150 Up to 150~210	6 to 12 month 2 to 6 month
Up to 40,000 ~70,000 and below	Clean	-15~65 Up to 65~100	+5~150 Up to 150~210	2 to 6 month 1 month
Any dn value	Dirty	Up to 65 Over 65	Up to 150 Over 150	1 wk.to 1 month 1 day to 2 wk.
Any dn value	Very Dirty	Any temp	Any temp	1 day to 1 wk.
Any dn value	Exposed to water splashes	Any temp	Any temp	Every day



The amount of filling grease during relubrication please refer to Table 24.

Table 24.

Bearing No.	Filling grease amount (g)	Bearing No.	Filling grease amount(g)
UC201S~203S, NA201S~203S	1.0	UC305, NA305,UK305	4.1
UC201~204, NA201~204	1.4	UC306, NA306,UK306	5.5
UC205, NA205, UK205	1.7	UC307, NA307,UK307	7.8
UC206, NA206, UK206, UCX05	2.9	UC305, NA305,UK305	10.0
UC207, NA207, UK207, UCX06	3.9	UC308, NA308,UK308	14.7
UC208, NA208, UK208 , UCX07	5.0	UC309, NA309,UK309	18.1
UC209, NA209, UK209, UCX08	6.0	UC311, NA311,UK311	23
UC210, NA210, UK210, UCX09	6.9	UC312, NA312,UK312	28
UC211, NA211, UK211, UCX 10	9.4	UC313, NA313,UK313	36
UC212, NA212, UK212, UCX11	12.6	UC314, NA314,UK314	43
UC213, NA213, NUK213,UCX 12	15.5	UC315, NA315,UK315	53
UC214, NA214, UK214, UCX13	19.3	UC316, NA316,UK316	60
UC215, NA215, UK215, UCX14	19.5	UC317, NA317,UK317	72
UC216, NA216, UK216, UCX15	26	UC318, NA318,UK317	86
UC217, NA217, UK217, UCX16	31	UC319, NA319,UK319	105
UC218, NA218, UK218, UCX17	40	UC320, NA320,UK320	126
UC220, NA220, UCX18	48	UC322, UK322	178
UCX20	67	UC324, UK324	227
		UC306, UK326	278
		UC328, UK328	342

Notes:

- (1)For TR bearings,the original amount of grease accounts for 30~40% ofthe bearing’s available volume. It is suggested that the amount of filling grease should refer to the original amount to avoid abnormal heat or lubricating grease leak caused by excessive filling grease.
- (2)The amount of filling grease for bearings with triple seals is 1.5 times as much as the figures in the table.
- (3)For bearings operating in a low speed, to improve their dust proof capacity,the amount of filling grease can be 2 times as much as the figures in the table.

#### 7.4. Grease Fittings

TR bearing units are , as a general rule, provided with a grease fitting made of bronze or steel, as shown in Table 25.

Grease fitting dimensions and designation of applicable bearing units are given in Table 26.

Table 25.

Housings No.	Grease fitting type and dimension
203~210 ,305~307,X05~X09	A,Type,M6x1
P204M~P207M,C203~C216, C305~C316	
211~210,308~328, X10~X20,C317~C328	A,Type,M8x1
P208M~P214M	A,Type,G1/8

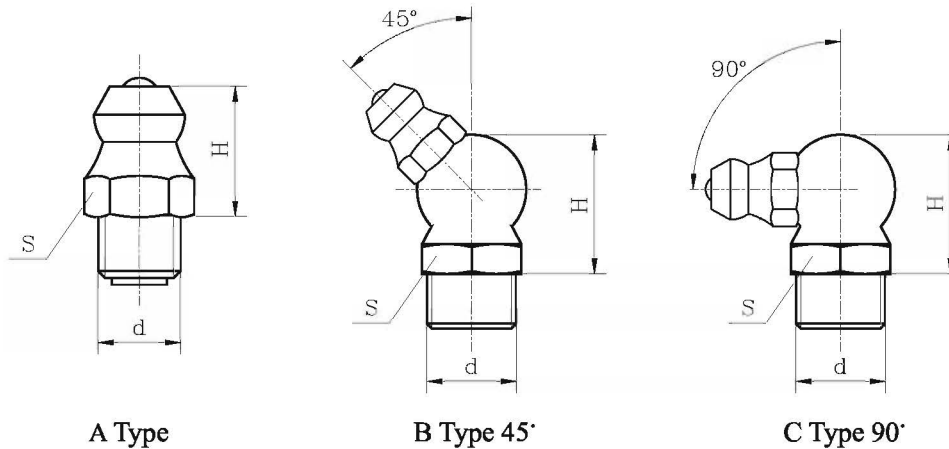

Table 26. Grease nipple dimensions and designations of applicable bearing units

Grease fitting Type	d	H(mm)	S(mm)
A Type	M6X1	8.5	7
	M8X1	10.5	10
	1/4-28UNF	8.5	7
	1/8-27NPT	9.5	11
	G1/8	10.5	11
B Type 45°	M6X1	15	10
	M8X1	15	10
	1/4-28UNF	15	10
	1/8-27NPT	15	10
B Type 90°	M6X1	15	10
	M8X1	15	10
	1/4-28UNF	15	10
	1/8-27NPT	14.5	10

### 8. Limiting Speed

The limiting speed of the ball bearing units are mainly determined by the fit between the bearings and the shafts. Under normal conditions, the fit for the setscrews type and eccentric locking collar type bearing unit is h7. h8 or h9 fit is applied when with light load and slow speed, while tighter fit j7 is applied when with heavy load and high speed. The shaft applied to the adapter sleeve bearing is h9 class, with IT5 class tolerances.

The speed ratings for ball bearing of series CS2(00)-2RS and CS3(00)-2RS are the same as deep groove ball bearings which are shown in Table 27.

The limiting speeds for the ball bearing units with different fits are shown in Table 29.

**Table 27. Limiting Speed (r/min)**

d (mm)	200 Series				300 Series				CS200 CS300	
	Shaft Tolerances				Shaft Tolerances				200Series	300Series
	j7(h9/IT5)	h7	h8	h9	j7(h9/IT5)	h7	h8	h9		
12	6700	5300	3800	1400	--	--	--	--	--	--
15	6700	5300	3800	1400	--	--	--	--	11000	--
17	6700	5300	3800	1400	--	--	--	--	10000	--
20	6000	4800	3400	1200	--	--	--	--	9000	--
25	5600	4000	3000	1000	5000	3600	2600	900	8000	7000
30	4500	3400	2400	850	4300	3000	2200	800	6700	6300
35	4000	3000	2000	750	3800	2800	2000	700	6000	5600
40	3600	2600	1900	670	3400	2400	1700	630	5600	5000
45	3200	2400	1700	600	3000	2200	1500	560	5000	4500
50	3000	2200	1600	560	2600	2000	1400	500	4800	4300
55	2600	2000	1400	500	2400	1800	1300	450	--	--
60	2400	1800	1200	450	2200	1700	1100	430	--	--
65	2200	1700	1100	430	2000	1500	1100	400	--	--
70	2200	1600	1100	400	1900	1400	1000	360	--	--
75	2000	1500	1000	380	1800	1300	900	340	--	--
80	1900	1400	950	340	1700	1200	850	320	--	--
85	1800	1300	900	320	1600	1100	800	300	--	--
90	1700	1200	800	300	1500	1100	750	280	--	--
95	--	--	--	--	1400	1000	700	260	--	--
100	--	--	--	--	1300	950	670	240	--	--
105	--	--	--	--	1200	900	630	220	--	--
110	--	--	--	--	1200	800	600	200	--	--
120	--	--	--	--	1100	750	530	190	--	--
130	--	--	--	--	1000	670	480	180	--	--
140	--	--	--	--	900	600	430	160	--	--

Note: 1. The h9/IT5 column fit for adapter sleeve type ball bearing units, and the rest j7~h9 column fit for the setscrews type and eccentric locking collar type ball bearing units.

2. The limiting speeds of ball bearings units with triple seals are 20% to 25% of the above figures.

### 9. Shafts Design

The ball bearing units are provided with hexagonal setscrews to fix the shafts. Under normal operating conditions, the inner rings are mounted on shafts by means of a loose fit to ensure convenience of shaft installation. In this case, the dimensional accuracy of the shafts is shown in Table 28.

**Table 28. Dimensional accuracy of the shafts to be used in the cylindrical bore bearings (Loose fit) ( $\mu$  m)**

Shafts Diameter (mm)		Deviation of tolerance in shaft									
		for lower speed		for medium speed		for rather high speed		for high speed			
		h9		h8		h7		j6		h6	
over	Incl.	max.	min.	max.	min.	max.	min.	max.	min.	max.	min.
10	18	0	-43	0	-27	0	-18	+8	-3	0	-11
18	30	0	-52	0	-33	0	-21	+9	-4	0	-13
30	50	0	-62	0	-39	0	-25	+11	-5	0	-16
50	80	0	-74	0	-46	0	-30	+12	-7	0	-19
80	120	0	-87	0	-54	0	-35	+13	-9	0	-22

When the ball bearing units are used at a high speed or under heavy load, the inner rings of the ball bearings should be mounted to the shafts by means of a tight fit. As shown in Table 29.

**Table 29. Dimensional accuracy of the shafts to be used in the cylindrical bore bearings (Tight fit) ( $\mu$  m)**

Shaft Diameter (mm)		Deviation of tolerance in shaft							
		higher speed		rather heavy load		highest speed		heavy load	
		m6		m7		n6		n7	
over	Incl.	max.	min.	max.	min.	max.	min.	max.	min.
10	18	+18	+7	+25	+7	+23	+12	+30	+12
18	30	+21	+8	+29	+8	+28	+15	+36	+15
30	50	+25	+9	+34	+9	+33	+17	+42	+17
50	80	+30	+11	+41	+11	+39	+20	+50	+20
80	120	+35	+13	+48	+13	+45	+23	+58	+23

Some bearings can be installed to the shafts by means of adapter sleeves. In this method, the bearing bore is made of 1:12 taper and the corresponding tapered adapter sleeves are applied. This is a convenient method that can be used as the intermediate bearings of a long shaft. In this case, the dimensional accuracy of shafts is shown in Table 30.



**Table 30 Dimensional accuracy of shafts to be used in tapered bore bearings. (um)**

Shafts Diameter (mm)		Deviation of tolerance <b>for shafts</b>			
		for short shafts		for long shafts	
		h9		h10	
over	incl.	max.	min.	max.	min.
10	18	0	-43	0	-70
18	30	0	-52	0	-84
30	50	0	-62	0	-100
50	80	0	-74	0	-120
80	120	0	-87	0	-140
120	180	0	-100	0	-160

Most industrial fans operate at high speeds. The inner ring of the ball bearing units should be mounted to the shafts by means of h5 or j5 fit. As shown in following table.

**Table 31 Dimensional accuracy of shafts to fans used in bearing units (um)**

Shaft diameter (mm)		Deviation of tolerance in shaft			
		h5		j5	
		max.	min.	max.	min.
over	Incl.				
18	30	0	-9	+5	-4
30	50	0	-11	+6	-5
50	80	0	-13	+6	-7
80	100	0	-15	+6	-9

## 10. Mounting of Bearings on Shafts

### 10.1 Setscrews Locking Type Bearings

There are two setscrews located at two places on one side of the wide inner ring 120° apart with which the bearings can be mounted to the shafts. When mounting the bearings to the shafts, the torque shown in the following table is recommended to tighten the setscrews to shafts.

Table 32. Proper tightening torque of setscrews

Bearings No.		Setscrews		Tightening torque	
		(mm)	(in.)	(N m)	(lbf in.)
UC201~UC203	SB201~SB203	M5X0.8	3.9	10-32UNF	32
UC204~UC206	UC305~UC306 SB204~SB207	M6X1	4.9	1/4-28UNF	43
UC207~UC209	UC307 SB208~SB211	M8X1	8.0	5/16-24UNF	70.5
UC210~UC212	UC308~UC309 SB212	M10X1.25	16.8	3/8-24UNF	148
UC213		M12X1.25	27.1	3/8-24UNF	148
UC214~UC217	UC310~UC314	M12X1.25	29.4	7/16-20UNF	235
UC218		M12X1.25	34.3	1/2-20UNF	260
	UC315~UC326	M14X1.5	54.2	1/2-20UNF	300
	UC317~UC319	M16X1.5	58.0	5/8-18UNF	478
	UC320~UC324	M18X1.5	78.0	5/8-18UNF	496
	UC326~UC328	M20X1.5			

In case of either the vibration is caused to the bearing; or 1) the alternating movement takes place, 2) the load applied to the bearings is large, 3) The shafts rotation speed is rapid, it is desired to provide with the filed seat or concave section at the part where the setscrews contact with the shafts. If large thrust load is charged, it is recommended that joggling tightened with nuts be used to install the bearings most effectively to the shafts. As shown in Fig. 3.

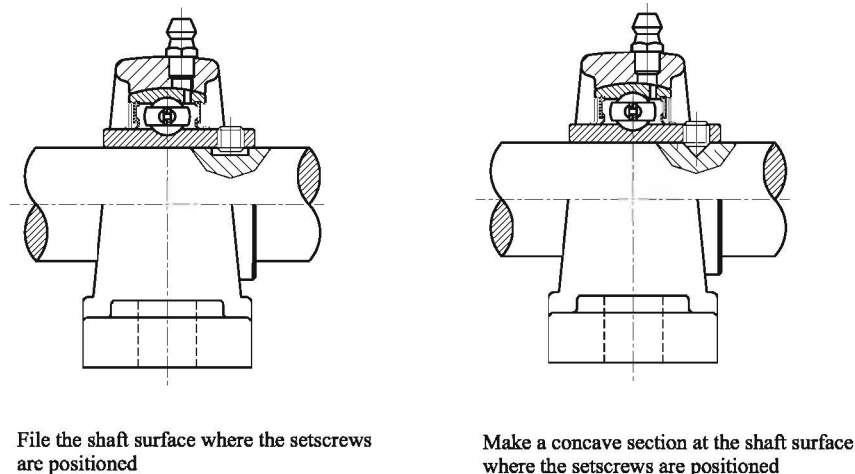

Fig.3

## 10.2 Adapter Sleeves Locking Type Bearings

The inner ring bore of this type of bearings has a taper of 1:12. The sleeves are installed to an arbitrary position. After the shake proof washers are inserted, the correct nuts tightening condition can be obtained if they are tightened enough by hand and then rotated by 2/5 to 3/5 revolution with a spanner.

After tightening the nuts, bend the shake proof washers within the slots. Otherwise, the nuts may loosen and creep may happen between the shaft and sleeves.

It is necessary to ensure that the nuts are not over tightened. As shown in Fig. 4.

## 10.3 Eccentric Locking Collar Type Bearings

The eccentric part of the collars mates with the inner rings of the bearings which is made eccentric with the collars. When locked to the shafts by hand in direction of the shafts rotation, the eccentric locking collars tighten automatically to the shafts by force of working radial loads. Then, lock the setscrews provided on the collar to fix the eccentric collars to the shafts.

## 10.4 Mounting Method of Housings

The desired installation order is: first install the housing, then the shaft and bearing. The bearing units can be easily installed, in principle, at any place. However, in order to have a long service life, it is desired that the mounting base is flat and rigid.

The pillow block type and flange type housings are desired that the angle between the surface on which the housing is mounted and the shaft be maintained to a tolerance of  $\pm 2^\circ$  (Fig.5).

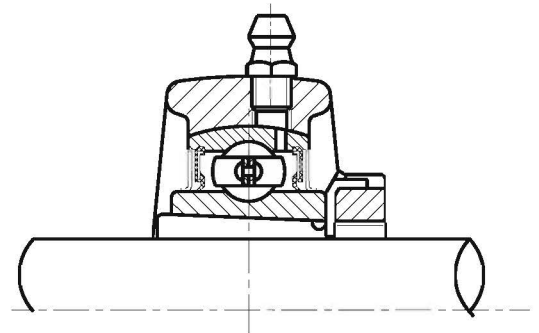

Fig.4.

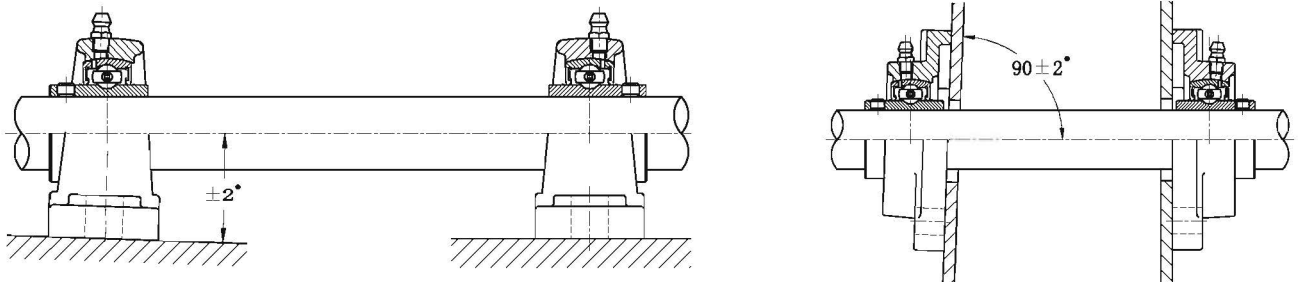

Fig.5.

### 10.5 Mounting Method of Take-up Units

The Take-up units are mounted on two parallel slides, bearing centers to be adjusted by adjustable bolts. The relevant parts dimensions are shown as Fig.6.

Mounting tolerances are shown in Table 33. Table 34. and Table 35.

Table 33. (mm)

Take-up No.	H' ±0.5	A'	d	D	N
T204	77	11	16	28	12
T205	77	11	16	28	12
T206	90	11	18	32	12
T207	90	11	18	32	12
T208	103	15	24	42	14
T209	103	15	24	42	14
T210	103	15	24	42	14
T211	131	20	30	56	20
T212	131	20	30	56	26
T213	152	24	36	60	26
T214	152	24	36	60	26
T215	152	24	36	60	26
T216	167	24	36	60	26
T217	175	28	42	65	30

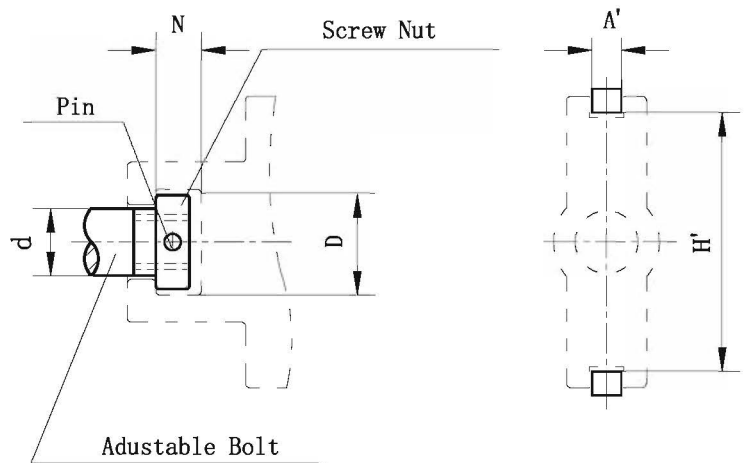

Fig.6

Table 34. (mm)

Take-up No.	H' ±0.5	A'	d	D	N
ST204	77	12.5	16	28	12
ST205	77	12.5	16	28	12
ST206	90	12.5	18	32	12
ST207	90	12.5	18	32	12
ST208	103	16.5	24	42	14
ST209	103	16.5	24	42	14
ST210	103	16.5	24	42	14
ST211	131	25	30	56	20
ST212	131	25	30	56	26

Table 35. (mm)

Take-up No.	H' ±0.5	A'	d	D	N
T305	81	11	22	32	12
T306	91	15	24	38	14
T307	101	15	26	40	16
T308	103	16	28	46	18
T309	113	16	30	50	20
T310	126	18	32	55	22
T311	141	20	34	60	24
T312	151	20	36	64	24
T313	161	24	38	64	26
T314	172	24	42	75	28
T315	182	24	42	75	28
T316	194	28	46	90	34
T317	206	30	46	90	34
T318	216	30	46	90	34
T319	230	32	50	95	38
T320	242	32	50	95	38
T322	262	36	52	100	38
T324	287	42	55	110	42
T326	322	46	60	120	48
T328	352	46	65	130	52
T328	382	46	70	140	56





11. Bearing Inserts — Life Estimation for Different Speeds and  $\frac{C_r}{P_r}$  Ratios.

Table 36.

$L_{10h}$ (hours)	$C_r/P_r$ when speed n=															
	(r/min)															
	50	100	200	300	500	750	900	1000	1500	1800	2000	2500	3000	4000	5000	6000
500	1.14	1.45	1.82	2.08	2.47	2.82	3.00	3.11	3.56	3.78	3.91	4.22	4.48	4.93	5.32	5.65
1000	1.44	1.82	2.29	2.62	3.11	3.56	3.78	3.91	4.48	4.76	4.93	5.31	5.65	6.21	6.70	7.11
1500	1.65	2.08	2.62	3.00	3.56	4.08	4.31	4.48	5.13	5.45	5.65	6.10	6.46	7.11	7.65	8.15
2000	1.82	2.29	2.88	3.30	3.91	4.48	4.76	4.93	5.65	6.00	6.21	6.69	7.11	7.81	8.43	8.96
3000	2.08	2.62	3.30	3.78	4.48	5.13	5.42	5.65	6.46	6.85	7.11	7.66	8.14	8.96	9.65	10.3
5000	2.47	3.11	3.91	4.48	5.32	6.08	6.46	6.70	7.66	8.14	8.43	9.09	9.65	10.6	11.5	12.2
7500	2.82	3.56	4.48	5.13	6.06	6.96	7.37	7.66	8.77	9.32	9.65	10.4	11.1	12.2	13.1	13.9
10000	3.11	3.91	4.93	5.65	6.70	7.66	8.14	8.43	9.65	10.3	10.6	11.4	12.2	13.4	14.5	15.3
15000	3.56	4.48	5.65	6.46	7.66	8.77	9.28	9.65	11.1	11.7	12.2	13.1	13.9	15.3	16.5	17.5
20000	3.91	4.93	6.21	7.11	8.43	9.65	10.3	10.6	12.2	12.9	13.4	14.4	15.3	16.8	18.2	19.3
30000	4.48	5.65	7.11	8.14	9.65	11.1	11.7	12.2	13.9	14.8	15.3	16.5	17.5	19.3	20.8	22.1
40000	4.93	6.21	7.81	8.96	10.6	12.2	12.9	13.4	15.3	16.3	16.8	18.2	19.3	21.2	22.9	24.3
60000	5.65	7.11	8.96	10.3	12.2	13.9	14.8	15.3	17.5	18.6	19.3	20.8	22.1	24.3	26.2	27.8
80000	6.21	7.81	9.83	11.3	13.4	15.3	16.3	16.8	19.3	20.5	21.2	22.9	24.3	26.7	28.8	30.7

Life estimation for UC212 insert bearing with steady radial load  $F_r = 3250$  N at a speed of 1500 r/min.

The dynamic load rating  $C_r$  of the inset bearing UC212 from page C-1 is 47800 N.

Since the bearing is not subject to axial load, the equivalent load  $P_r = F_r \times f_d = 3250$  N  $\times$  1.2 = 3900 N (When no shocking load or minor shocking load, shocking load factor  $f_d = 1 \sim 1.2$ ).

Using the load ratio tables, an approximate life can be obtained by locating the nearest  $C_r/P_r$  value in the appropriate r/min column.

$$\text{Therefore for } C_r/P_r = \frac{47800}{3900} = 12.256$$

Under the  $n = 1500$  r/min column, the nearest  $C_r/P_r$  value is 12.2 with give an approximate life of 20000 hours.



# DIMENSION TABLE

## Contents of ball bearing units and insert Bearings

### Pillow blocks

UCP2 .....	B-2
UCP2M .....	B-3
NAP2 .....	B-4
NAP2M .....	B-5
UKP2+H .....	B-6
UKP2M+H .....	B-7
SBP2G .....	B-8
SAP2G .....	B-9
UCPK2 .....	B-10
NAPK2 .....	B-11
UCPX .....	B-12
UCP3 .....	B-13
NAP3 .....	B-14
UKP3+H .....	B-15
SALP2G,SBLP2G .....	B-16
UCPH2 .....	B-17
UCPA2 .....	B-18
UCPA2A .....	B-19
UCPG2 .....	B-20
SAPP2,SBPP2 .....	B-21

### Square flange units

UCF2 .....	B-22
NAF2 .....	B-23
UKF2+H .....	B-24
SAF2G .....	B-25
SBF2G .....	B-26
UCFX .....	B-27
UCFU2 .....	B-28
NAFU2 .....	B-29
SAFU2G .....	B-30
UCF3 .....	B-31
NAF3 .....	B-32
UKF3+H .....	B-33
UCFS3 .....	B-34
NAFS3 .....	B-35
UKFS3+H .....	B-36

### Oval flange units

UCFL2 .....	B-37
NAFL2 .....	B-38
UKFL2+H .....	B-39
UCFLX .....	B-40
SAFL2G .....	B-41
SBFL2G .....	B-42
UCFLU2 .....	B-43
NAFLU2 .....	B-44
SAFLU2G .....	B-45
UCFL3 .....	B-46
NAFL3 .....	B-47
UKFL3+H .....	B-48
SALF2G,SBLF2G .....	B-49
SALFTC2G,SBLFTC2G .....	B-50
SAFD2G,SBFD2G .....	B-51
SBPFTD2G,SAPFTD2G .....	B-52
SAFCT2G,SBFCT2G .....	B-53
SBPFL2,SAPFL2 .....	B-54

### Round flange units

UCFC2 .....	B-55
NAFC2 .....	B-56
UKFC2+H .....	B-57
SBPF2,SAPF2 .....	B-58
SBPFT2,SAPFT2 .....	B-59

### Take-up units

UCT2 .....	B-60
UCT3 .....	B-61
UCST2 .....	B-62
NAT2 .....	B-63
NAT3 .....	B-64
UKT2+H .....	B-65
UKT3+H .....	B-66

### Other

UCC2 .....	B-67
UCC3 .....	B-68
UCFB2 .....	B-69
UCFA2 .....	B-70
UCHA2 .....	B-71
Pressed Housing Agricultural Disk Bearings .....	B-72

### Insert Bearings

UC2,RB2 .....	C-1
UC2T .....	C-2
UCX .....	C-3
UC3 .....	C-4
NA2,HC2 .....	C-5
NA3 .....	C-6
UK2 .....	C-7
UK3 .....	C-8
ER2 .....	C-9
ER2T .....	C-10
SER2 .....	C-11
SA2,SA2G,CSA1,CSA2 .....	C-12
SB2,SB2G,CSB2 .....	C-13
GRA2,GRA2G,RA2 .....	C-14
SA0,CSA0 .....	C-15
NAA3 .....	C-15
CS2 .....	C-16
ORAE .....	C-16

Disc Bearings For Agricultural Machinery .....	C-17
--	------

Disc Bearings For Agricultural Machinery .....	C-18
--	------

Hex-bore Ball Bearing .....	C-19
-----------------------------	------

### Eccentric Locking Collars

A200 .....	C-20
A300 .....	C-21

### Adapters

H2300 .....	C-22
-------------	------

### Appendices

Conversion factors for British and S.I.Units .....	D-1
Metric-inch conversion table .....	D-1
Inch-mm conversion table .....	D-2
Temperature conversion table .....	D-3
kgf-N conversion table .....	D-4
kg-lb conversion table .....	D-5
A table of mounted units references .....	D-6



# PILLOW BLOCKS

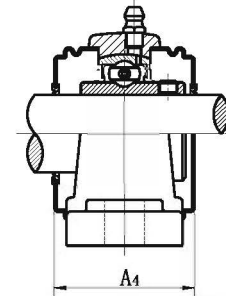
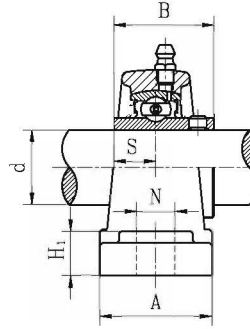
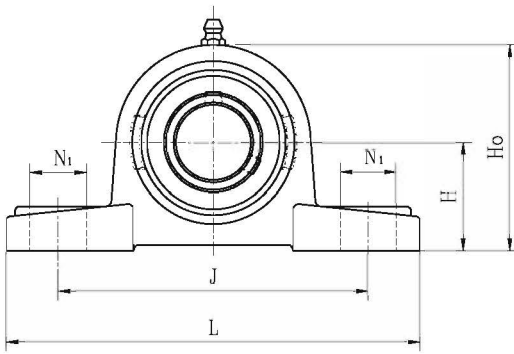

UCP2  
Setscrew type

S-UCP200E1  
SM-UCP200E1  
With end cover

Unit No.	Shaft Dia.		Dimensions(mm).										Bolt Size	Bearing No.	Housing No.	Mass (kg)	Available		
	d (in.)	d (mm)	H	L	J	A	N	N <sub>1</sub>	H <sub>1</sub>	H <sub>0</sub>	S	B					A <sub>4</sub>	N	N <sub>1</sub>
UCP201S 201-8S 202S 202-10S 203S 203-11S	1/2 5/8 11/16	12 15 17	30.2	125	96	32	12	16	13	57	11.5	27.4	--	M10	UC201S 201-8S 202S 202-10S 203S 203-11S	P203S	0.53 0.52 0.51	--	--
UCP201 201-8 202 202-10 203 203-11	1/2 5/8 11/16	12 15 17	30.2	127	96	37	13	19	14	60.7	12.7	31	--	M10	UC201 201-8 202 202-10 203 203-11	P203	0.72 0.70 0.69	--	--
UCP204-12 204	3/4	20	33.3	127	96	37	13	16	14	65	12.7	31	45	M10	UC204-12 204	P204	0.69	13	19
UCP205-14 205-15 205 205-16	7/8 15/16 1	25	36.5	140	105	38	13	19	15	71	14.3	34	48	M10	UC205-14 205-15 205 205-16	P205	0.82	--	--
UCP206-18 206 206-19 206-20	1-1/8 1-3/16 1-1/4	30	42.9	160	121	44	14	19	16	83	15.9	38.1	52	M12	UC206-18 206 206-19 206-20	P206	1.22	17	21
UCP207-20 207-21 207-22 207 207-23	1-1/4 1-5/16 1-3/8 1-7/16	35	47.6	167	126	48	15	19	17	93	17.5	42.9	59	M12	UC207-20 207-21 207-22 207 207-23	P207	1.61	17	21
UCP208-24 208-25 208	1-1/2 1-9/16	40	49.2	180	136	52	15	21	18	100	19	49.2	68	M12	UC208-24 208-25 208	P208	1.99	17	23
UCP209-26 209-27 209-28 209	1-5/8 1-11/16 1-3/4	45	54	190	146	54	15	21	20	108	19	49.2	70	M12	UC209-26 209-27 209-28 209	P209	2.36	17	23
UCP210-30 210-31 210	1-7/8 1-15/16	50	57.2	204	159	57	19	22	21	114	19	51.6	75	M16	UC210-30 210-31 210	P210	2.73	--	--
UCP211-32 211-34 211 211-35	2 2-1/8 2-3/16	55	63.5	217	172	60	19	22	22	126	22.2	55.6	78	M16	UC211-32 211-34 211 211-35	P211	3.42	--	--
UCP212-36 212 212-38 212-39	2-1/4 2-3/8 2-7/16	60	69.9	238	186	66	19	25	24	138	25.4	65.1	91	M16	UC212-36 212 212-38 212-39	P212	4.66	--	--
UCP213-40 213	2-1/2	65	76.2	262	203	70	23	29	26	151	25.4	65.1	98	M20	UC213-40 213	P213	5.95	25	29
UCP214-44 214	2-3/4	70	79.4	266	210	72	23	29	27	157	30.2	74.6	--	M20	UC214-44 214	P214	6.56 7.43	25	29
UCP215 215-48	3	75	82.6	274	217	74	25	29	28	164	33.3	77.8	--	M20	UC215 215-48	P215	7.43	--	--
UCP216		80	88.9	292	232	78	25	30	30	175	33.3	82.6	--	M20	UC216	P216	8.83	--	--
UCP217-52 217	3-1/4	85	95.2	310	247	83	25	30	32	187	34.1	85.7	--	M20	UC217-52 217	P217	10.8	--	--
UCP218-56 218	3-1/2	90	101.6	326	262	88	27	30	33	200	39.7	96	--	M22	UC218-56 218	P218	12.8	27	33
UCP220 220-64	4	100	115	380	305	95	30	36	40	225	42	108	--	M24	UC220 220-64	P220	26.3	--	--

Note: Grease fittings can locate at 45° position of housings front right side.



# PILLOW BLOCKS WITH WEBBED HOUSINGS

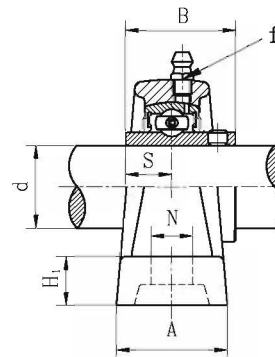
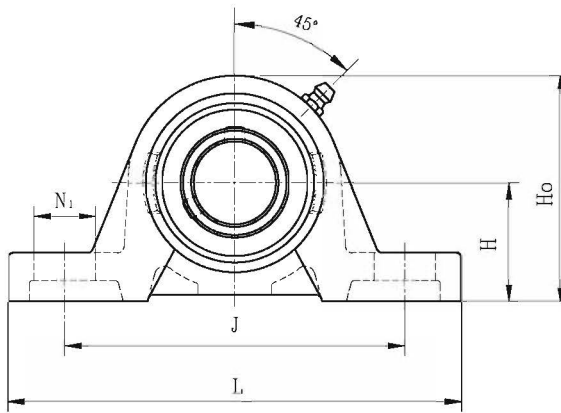

UCP200M  
Setscrew type

Unit No.	Shaft Dia.		Dimensions(mm).											Bolt Size	Bearing No.	Housing No.	Mass (kg)
	d		H	L	J	A	N	N <sub>1</sub>	H <sub>1</sub>	H <sub>0</sub>	S	B	f				
	(in.)	(mm)															
UCP204-12M 204M	3/4	20	33.3	127	97	32	11.5	20.5	14	64	12.7	31	M6	M10	UC204-12 204	P204M	0.62
UCP205-14M 205-15M 205M 205-16M	7/8 15/16 1	25	36.5	130	102	36	11.5	19.5	16	70	14.3	34	M6	M10	UC205-14 205-15 205 205-16	P205M	0.80
UCP206-18M 206M 206-19M 206-20M	1-1/8 1-3/16 1-1/4	30	42.9	152	117.5	40	14	23.5	17	82	15.9	38.1	M6	M12	UC206-18 206 206-19 206-20	P206M	1.17
UCP207-20M 207-21M 207-22M 207M 207-23M	1-1/4 1-5/16 1-3/8 1-7/16	35	47.6	160	126	45	14	21	19	93	17.5	42.9	M6	M12	UC207-20 207-21 207-22 207 207-23	P207M	1.61
UCP208-24M 208-25M 208M	1-1/2 1-9/16	40	49.2	175	135.5	48	14	24.5	19	99	19	49.2	G1/8	M12	UC208-24 208-25 208	P208M	1.89
UCP209-26M 209-27M 209-28M 209M	1-5/8 1-11/16 1-3/4	45	54	187	143.5	48	14	22.5	21	107	19	49.2	G1/8	M12	UC209-26 209-27 209-28 209	P209M	2.26
UCP210-30M 210-31M 210M	1-7/8 1-15/16	50	57.2	203	157	54	18	26	22	114	19	51.6	G1/8	M16	UC210-30 210-31 210	P210M	2.69
UCP211-32M 211-34M 211M 211-35M	2 2-1/8 2-3/16	55	63.5	219	171.5	60	18	27.5	24	125	22.2	55.6	G1/8	M16	UC211-32 211-34 211 211-35	P211M	3.65
UCP212-36M 212M 212-38M 212-39M	2-1/4 2-3/8 2-7/16	60	69.9	240	190.5	60	18	29.5	26.5	137	25.4	65.1	G1/8	M16	UC212-36 212 212-38 212-39	P212M	4.79
UCP213-40M 213M	2-1/2	65	76.2	257	203	65	22	35	29	150	25.4	65.1	G1/8	M20	UC213-40 213	P213M	5.81
UCP214-44M 214M	2-3/4	70	79.4	260	210	65	22	30	29	155	30.2	74.6	G1/8	M20	UC214-44 214	P214M	6.34



# PILLOW BLOCKS

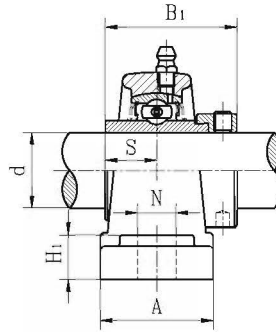
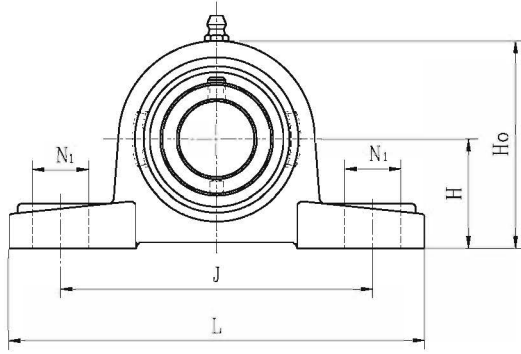

## NAP2 Eccentric Locking Collar type

Unit No.	Shaft Dia.		Dimensions(mm).										Bolt Size	Bearing No.	Housing No.	Mass (kg)	Available	
	d (in.)	d (mm)	H	L	J	A	N	N <sub>1</sub>	H <sub>1</sub>	Ho	S	B <sub>1</sub>					N	N <sub>1</sub>
NAP201S 201-8S 202S 202-10S 203S 203-11S	1/2 5/8 11/16	12 15 17	30.2	125	96	32	12	16	13	57	13.9	37.3	M10	NA201S 201-8S 202S 202-10S 203S 203-11S	P203S	0.64 0.63 0.61	--	--
NAP201 201-8 202 202-10 203 203-11	1/2 5/8 11/16	12 15 17	30.2	127	96	37	13	19	14	60.7	17	43.5	M10	NA201 201-8 202 202-10 203 203-11	P203	0.79 0.76 0.75	--	--
NAP204-12 204	3/4	20	33.3	127	96	37	13	16	14	65	17	43.5	M10	NA204-12 204	P204	0.74	13	19
NAP205-14 205-15 205 205-16	7/8 15/16 1	25	36.5	140	105	38	13	19	15	71	17.4	44.3	M10	NA205-14 205-15 205 205-16	P205	0.87	--	--
NAP206-18 206 206-19 206-20	1-1/8 1-3/16 1-1/4	30	42.9	160	121	44	14	19	16	83	18.2	48.3	M12	NA206-18 206 206-19 206-20	P206	1.29	17	21
NAP207-20 207-21 207-22 207 207-23	1-1/4 1-5/16 1-3/8 1-7/16	35	47.6	167	126	48	15	19	17	93	18.8	51.1	M12	NA207-20 207-21 207-22 207 207-23	P207	1.68	17	21
NAP208-24 208-25 208	1-1/2 1-9/16	40	49.2	180	136	52	15	21	18	100	21.4	56.3	M12	NA208-24 208-25 208	P208	2.10	17	23
NAP209-26 209-27 209-28 209	1-5/8 1-11/16 1-3/4	45	54	189	146	54	15	21	20	108	21.4	56.3	M12	NA209-26 209-27 209-28 209	P209	2.48	17	23
NAP210-30 210-31 210	1-7/8 1-15/16	50	57.2	204	159	57	19	22	21	114	24.6	62.7	M16	NA210-30 210-31 210	P210	2.90	--	--
NAP211-32 211-34 211 211-35	2 2-1/8 2-3/16	55	63.5	217	172	60	19	22	22	126	27.7	71.3	M16	NA211-32 211-34 211 211-35	P211	3.67	--	--
NAP212-36 212 212-38 212-39	2-1/4 2-3/8 2-7/16	60	69.9	238	186	66	19	25	24	138	30.9	77.7	M16	NA212-36 212 212-38 212-39	P212	4.94	--	--
NAP213-40 213	2-1/2	65	76.2	262	203	70	23	29	26	151	34.1	85.7	M20	NA213-40 213	P213	6.34	25	29
NAP214-44 214	2-3/4	70	79.4	266	210	72	23	29	27	157	34.1	85.7	M20	NA214-44 214	P214	6.60	25	29
NAP215 215-48	3	75	82.6	274	217	74	25	29	28	164	37.3	92.1	M20	NA215 215-48	P215	7.89	--	--
NAP216		80	88.9	292	232	78	25	30	30	175	37.3	95.2	M20	NA216	P216	9.45	--	--
NAP217-52 217	3-1/4	85	95.2	310	247	83	25	30	32	187	23.4	73.2	M20	NA217-52 217	P217	11.1	--	--
NAP218-56 218	3-1/2	90	101.6	326	262	88	27	30	33	200	24.5	72.5	M22	NA218-56 218	P218	12.76	27	33
NAP220		100	115	380	305	95	30	36	40	225	50	125.4	M24	NA220	P220	12.76	--	--

Note: Grease fittings can locate at 45° position of housings front right side.



# PILLOW BLOCKS WITH WEBBED HOUSINGS

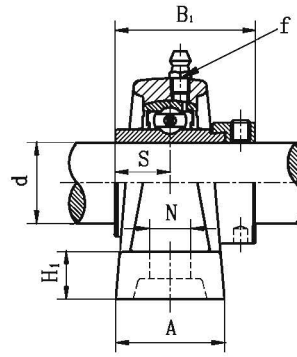
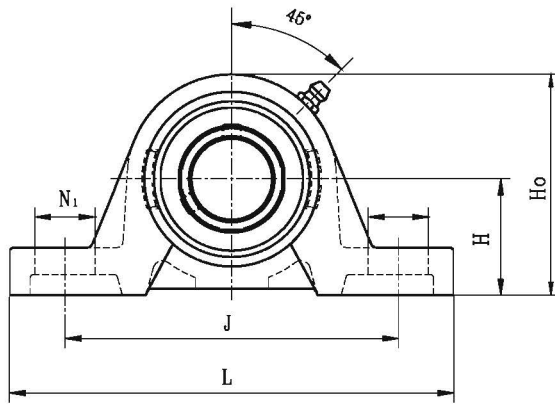

**NAP200M**  
Eccentric Locking Collars Type

Unit No.	Shaft Dia.		Dimensions(mm).											Bolt Size	Bearing No.	Housing No.	Mass (kg)
	d (in.)	(mm)	H	L	J	A	N	N <sub>1</sub>	H <sub>1</sub>	H <sub>0</sub>	S	B <sub>1</sub>	f				
NAP204-12M 204M	3/4	20	33.3	127	97	32	11.5	20.5	14	64	17	43.5	M6	M10	NA204-12 204	P204M	0.67
NAP205-14M 205-15M 205M 205-16M	7/8 15/16 1	25	36.5	130	102	36	11.5	19.5	16	70	17.4	44.3	M6	M10	NA205-14 205-15 205 205-16	P205M	0.85
NAP206-18M 206M 206-19M 206-20M	1-1/8 1-3/16 1-1/4	30	42.9	152	117.5	40	14	23.5	17	82	18.2	48.3	M6	M12	NA206-18 206 206-19 206-20	P206M	1.24
NAP207-20M 207-21M 207-22M 207M 207-23M	1-1/4 1-5/16 1-3/8 1-7/16	35	47.6	160	126	45	14	21	19	93	18.8	51.1	M6	M12	NA207-20 207-21 207-22 207 207-23	P207M	1.68
NAP208-24M 208-25M 208M	1-1/2 1-9/16	40	49.2	175	135.5	48	14	24.5	19	99	21.4	56.3	G1/8	M12	NA208-24 208-25 208	P208M	2.00
NAP209-26M 209-27M 209-28M 209M	1-5/8 1-11/16 1-3/4	45	54	187	143.5	48	14	22.5	21	107	21.4	56.3	G1/8	M12	NA209-26 209-27 209-28 209	P209M	2.38
NAP210-30M 210-31M 210M	1-7/8 1-15/16	50	57.2	203	157	54	18	26	22	114	24.6	62.7	G1/8	M16	NA210-30 210-31 210	P210M	2.86
NAP211-32M 211-34M 211M 211-35M	2 2-1/8 2-3/16	55	63.5	219	171.5	60	18	27.5	24	125	27.7	71.3	G1/8	M16	NA211-32 211-34 211 211-35	P211M	3.90
NAP212-36M 212M 212-38M 212-39M	2-1/4 2-3/8 2-7/16	60	69.9	240	190.5	60	18	29.5	26.5	137	30.9	77.7	G1/8	M16	NA212-36 212 212-38 212-39	P212M	5.07
NAP213-40M 213M	2-1/2	65	76.2	257	203	65	22	35	29	150	34.1	85.7	G1/8	M20	NA213-40 213	P213M	6.20
NAP214-44M 214M	2-3/4	70	79.4	260	210	65	22	30	29	155	34.1	85.7	G1/8	M20	NA214-44 214	P214M	6.38

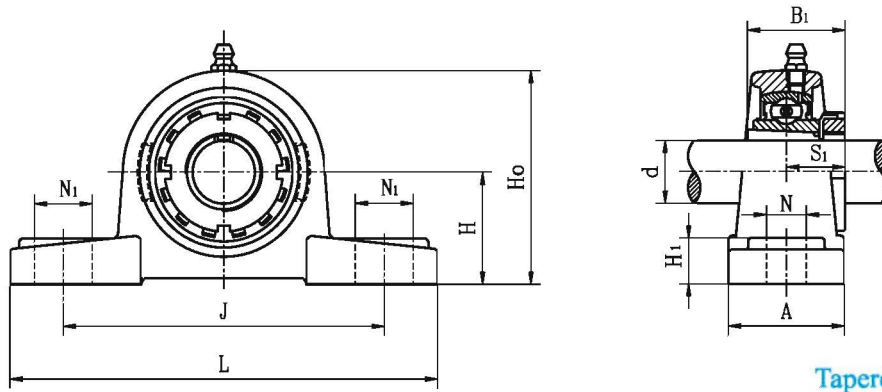

**UKP2+H**  
Tapered bore, adapter type

Unit No.	Shaft Dia.		Dimensions(mm).										Bolt Size	Bearing No.	Housing No.	Adapter No.	Mass (kg)	Available	
	d		H	L	J	A	N	N <sub>1</sub>	H <sub>1</sub>	H <sub>0</sub>	S <sub>1</sub>	B <sub>1</sub>						N	N <sub>1</sub>
	(in.)	(mm)																	
UKP205+HE2305 205+H2305	3/4	20	36.5	140	105	38	13	19	15	71	18.5	35	M10	UK205	P205	HE2305 H2305	0.86	--	--
UKP206+HS2306 206+HA2306 206+H2306 206+HE2306	7/8 15/16 1	25	42.9	160	121	44	14	19	16	83	20.5	38	M12	UK206	P206	HS2306 HA2306 H2306 HE2306	1.29	17	21
UKP207+HS2307 207+H2307 207+HA2307	1-1/8 1-3/16	30	47.6	167	126	48	15	19	17	93	22.5	43	M12	UK207	P207	HS2307 H2307 HA2307	1.66	17	21
UKP208+HE2308 208+HS2308 208+H2308	1-1/4 1-3/8	35	49.2	180	136	52	15	21	18	100	24.5	46	M12	UK208	P208	HE2308 HS2308 H2308	2.05	17	23
UKP209+HA2309 209+HE2309 209+H2309	1-7/16 1-1/2	40	54	190	146	54	15	21	20	108	26	50	M12	UK209	P209	HA2309 HE2309 H2309	2.47	17	23
UKP210+HS2310 210+HA2310 210+HE2310 210+H2310	1-5/8 1-11/16 1-3/4	45	57.2	204	159	57	19	22	21	114	27.5	55	M16	UK210	P210	HS2310 HA2310 HE2310 H2310	2.91	--	--
UKP211+HS2311 211+HA2311 211+H2311 211+HE2311	1-7/8 1-15/16 2	50	63.5	217	172	60	19	22	22	126	28.5	59	M16	UK211	P211	HS2311 HA2311 H2311 HE2311	3.58	--	--
UKP212+HS2312 212+H2312	2-1/8	55	69.9	238	186	66	19	25	24	138	31	62	M16	UK212	P212	HS2312 H2312	4.76	--	--
UKP213+HA2313 213+HE2313 213+H2313 213+HS2313	2-3/16 2-1/4 2-3/8	60	76.2	262	203	70	23	29	26	151	32	65	M20	UK213	P213	HA2313 HE2313 H2313 HS2313	6.03	25	29
UKP215+HA2315 215+HE2315 215+H2315	2-7/16 2-1/2	65	82.6	274	217	74	25	29	28	164	35.5	73	M20	UK215	P215	HA2315 HE2315 H2315	7.8	--	--
UKP216+HA2316 216+HE2316 216+H2316	2-11/16 2-3/4	70	88.9	292	232	78	25	30	30	175	39	78	M20	UK216	P216	HA2316 HE2316 H2316	9.30	--	--
UKP217+H2317		75	95.2	310	247	83	25	30	32	187	40	82	M20	UK217	P217	H2317	11.2	--	--
UKP218+H2318		80	101.6	326	262	88	27	30	33	200	42	86	M22	UK218	P218	H2318	13.1	27	33

Note: Grease fittings can locate at 45° position of housings front right side.



# PILLOW BLOCKS WITH WEBBED HOUSINGS

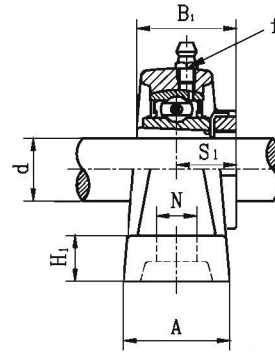
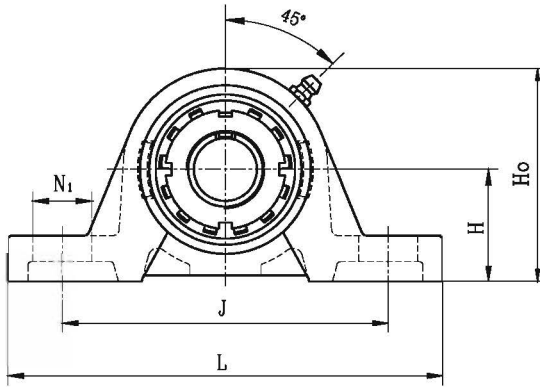

UKP200M+H  
Tapered bore, adapter type

Unit No.	Shaft Dia.		Dimensions(mm).											Bolt Size	Bearing No.	Housing No.	Adapter No.	Mass (kg)
	d (in.)	(mm)	H	L	J	A	N	N <sub>1</sub>	H <sub>1</sub>	H <sub>o</sub>	S <sub>1</sub>	B <sub>1</sub>	f					
UKP205M+HE2305 205M+H2305	3/4	20	36.5	130	102	36	11.5	19.5	16	70	18.5	35	M6	M10	UK205	P205M	HE2305 H2305	0.84
UKP206M+HS2306 206M+HA2306 206M+H2306 206M+HE2306	7/8 15/16 1	25	42.9	152	117.5	40	14	23.5	17	82	20.5	38	M6	M12	UK206	P206M	HS2306 HA2306 H2306 HE2306	1.24
UKP207M+HS2307 207M+H2307 207M+HA2307	1-1/8 1-3/16	30	47.6	160	126	45	14	21	19	93	22.5	43	M6	M12	UK207	P207M	HS2307 H2307 HA2307	1.66
UKP208M+HE2308 208M+HS2308 208M+H2308	1-1/4 1-3/8	35	49.2	175	135.5	48	14	24.5	19	99	24.5	46	G1/8	M12	UK208	P208M	HE2308 HS2308 H2308	1.95
UKP209M+HA2309 209M+HE2309 209M+H2309	1-7/16 1-1/2	40	54	187	143.5	48	14	22.5	21	107	26	50	G1/8	M12	UK209	P209M	HA2309 HE2309 H2309	2.37
UKP210M+HS2310 210M+HA2310 210M+HE2310 210M+H2310	1-5/8 1-11/16 1-3/4	45	57.2	203	157	54	18	26	22	114	27.5	55	G1/8	M16	UK210	P210M	HS2310 HA2310 HE2310 H2310	2.87
UKP211M+HS2311 211M+HA2311 211M+H2311 211M+HE2311	1-7/8 1-15/16 2	50	63.5	219	171.5	60	18	27.5	24	125	28.5	59	G1/8	M16	UK211	P211M	HS2311 HA2311 H2311 HE2311	3.81
UKP212M+HS2312 212M+H2312	2-1/8	55	69.9	240	190.5	60	18	29.5	26.5	137	31	62	G1/8	M16	UK212	P212M	HS2312 H2312	4.89
UKP213M+HA2313 213M+HE2313 213M+H2313 213M+HS2313	2-3/16 2-1/4 2-3/8	60	76.2	257	203	65	22	35	29	150	32	65	G1/8	M20	UK213	P213M	HA2313 HE2313 H2313 HS2313	5.89



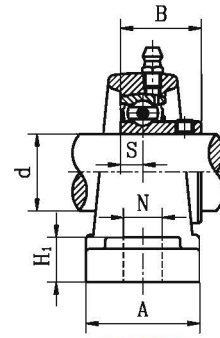
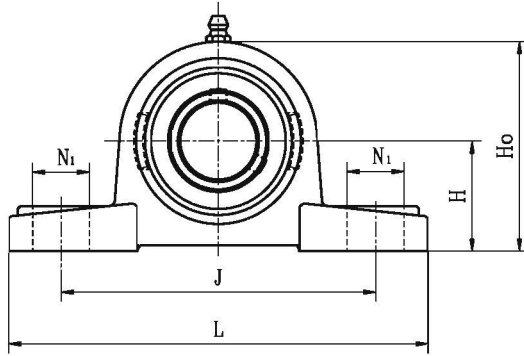

**SBP2G**  
Setscrew type

Unit No.	Shaft Dia.		Dimensions(mm).										Bolt Size	Bearing No.	Housing No.	Mass (kg)	Available		
	d (in.)	d (mm)	H	L	J	A	N	N <sub>1</sub>	H <sub>1</sub>	H <sub>0</sub>	S	B					N	N <sub>1</sub>	
																			N
SBP201G		12																	
201-8G	1/2	15	30.2	125	96	32	12	16	13	57	6	22	M10	SB201G	P203S	0.52	--	--	
202G	5/8	17												201-8G					
202-10G														202G					
203G	11/16													202-10G					
203-11G														203G					
SBP204-12G	3/4	20	33.3	127	96	37	13	16	14	65	7	25	M10	SB204-12G	P204	0.66	13	19	
204G														204G					
SBP205-14G	7/8	25	36.5	140	105	38	13	19	15	71	7.5	27	M10	SB205-14G	P205	0.79	--	--	
208-15G	15/16													205-15G					
205G	1													205G					
205-16G														205-16G					
SBP206-18G	1- 1/8	30	42.9	160	121	44	14	19	16	83	8	30	M12	SB206-18G	P206	1.16	17	21	
206G	1- 3/16													206G					
206-19G	1- 1/4													206-19G					
206-20G														206-20G					
SBP207-20G	1- 1/4													SB207-20G	P207	1.52	17	21	
207-21G	1- 5/16													207-21G					
207-22G	1- 3/8	35	47.6	167	126	48	15	19	17	93	8.5	32	M12	207-22G					
207G	1- 7/16													207G					
207-23G														207-23G					
SBP208-24G	1- 1/2													SB208-24G	P208	1.84	17	23	
208-25G	1- 9/16	40	49.2	180	136	52	15	21	18	100	9	34	M12	208-25G					
208G														208G					
SBP209-26G	1-5/8													SB209-26G	P209	2.24	17	23	
209-27G	1-11/16													209-27G					
209-28G	1-3/4	45	54	190	146	54	15	21	20	108	10.2	41.2	M12	209-28G					
209G														209G					
SBP210-30G	1-7/8													SB210-30G	P210	2.61	--	--	
210-31G	1-15/16	50	57.2	204	159	57	19	22	21	114	10.9	43.5	M16	210-31G					
210														210					
SBP211-32G	2													SB211-32G	P211	3.30	--	--	
211-34G	2-1/8	55	63.5	217	172	60	19	22	22	126	11.8	45.3	M16	211-34G					
211G	2-3/16													211G					
211-35G														211-35G					
SBP212-36G	2-1/4													SB212-36G	P212	4.42	--	--	
212G	2-3/8	60	69.9	238	186	66	19	25	24	138	14.9	53.7	M16	212G					
212-38G	2-7/16													212-38G					
212-39G														212-39G					

Remarks: The numbers indicate relubricatable type. If maintenance free type is needed, please order without suffix "G".

Note: Grease fittings can locate at 45° position of housings front right side.

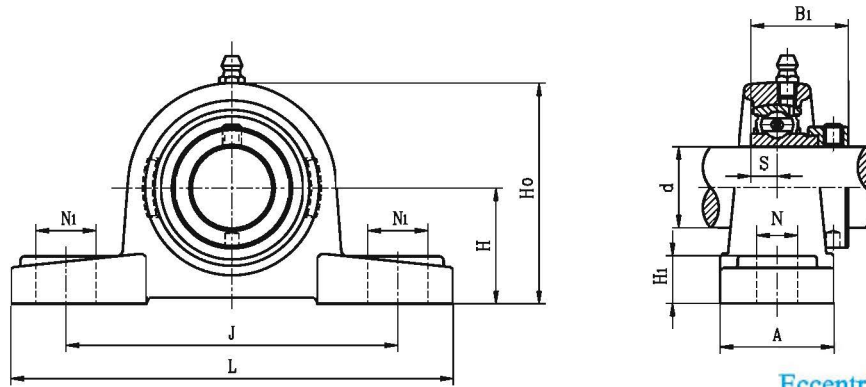

SAP2G  
Eccentric locking collar type

Unit No.	Shaft Dia.		Dimensions(mm).										Bolt Size	Bearing No.	Housing No.	Mass (kg)	Available		
	d (in.)	d (mm)	H	L	J	A	N	N <sub>1</sub>	H <sub>1</sub>	H <sub>0</sub>	S	B <sub>1</sub>					N	N <sub>i</sub>	
SAP201G		12													SA201G		0.54		
201-8G	1/2	15	30.2	125	96	32	12	16	13	57	6.5	28.6	M10	SA201G	P203S	0.53	--	--	
202G															202G				
202-10G	5/8	17													202-10G				
203G															203G		0.51		
203-11G	11/16														203-11G				
SAP204-12G	3/4	20	33.3	127	96	37	13	16	14	65	7.5	30.9	M10	SA204-12G	P204	0.69	13	19	
204G														204G					
SAP205-14G	7/8														SA205-14G				
205-15G	15/16		36.5	140	105	38	13	19	15	71	7.5	30.9	M10	205-15G	P205	0.81	--	--	
205G		25												205G					
205-16G	1													205-16G					
SAP206-18G	1-1/8	30	42.9	160	121	44	14	19	16	83	9	35.7	M12	SA206-18G		1.21			
206G														206G	P206		17	21	
206-19G	1-3/16													206-19G					
206-20G	1-1/4													206-20G					
SAP207-20G	1-1/4														SA207-20G				
207-21G	1-5/16		47.6	167	126	48	15	19	17	93	9.5	38.9	M12	207-21G	P207	1.58	17	21	
207-22G	1-3/8													207-22G					
207G		35												207G					
207-23G	1-7/16													207-23G					
SAP208-24G	1-1/2		49.2	180	136	52	15	21	18	100	11	43.7	M12	SA208-24G					
208-25G	1-9/16													208-25G	P208	1.97	17	23	
208G		40												208G					
SAP209-26G	1-5/8		54	190	146	54	15	21	20	108	11	43.7	M12	SA209-26G					
209-27G	1-11/16													209-27G	P209	2.34	17	23	
209-28G	1-3/4													209-28G					
209G		45												209G					
SAP210-30G	1-7/8		57.2	204	159	57	19	22	21	114	11	43.7	M16	SA210-30G					
210-31G	1-15/16													210-31G	P210	2.68	--	--	
210G		50												210G					
SAP211-32G	2		63.5	217	172	60	19	22	22	126	12	48.4	M16	SA211-32G					
211-34G	2-1/8													211-34G	P211	3.42	--	--	
211G		55												211G					
211-35G	2-3/16													211-35G					
SAP212-36G	2-1/4		69.9	238	186	66	19	25	24	138	12	49.3	M16	SA212-36G					
212G		60												212G	P212	4.51	--	--	
212-38G	2-3/8													212-38G					
212-39G	2-7/16													212-39G					

Remarks: The numbers indicate relubricatable type. If maintenance free type is needed, please order without suffix "G".

Note: Grease fittings can locate at 45° position of housings front right side.



# PILLOW BLOCKS

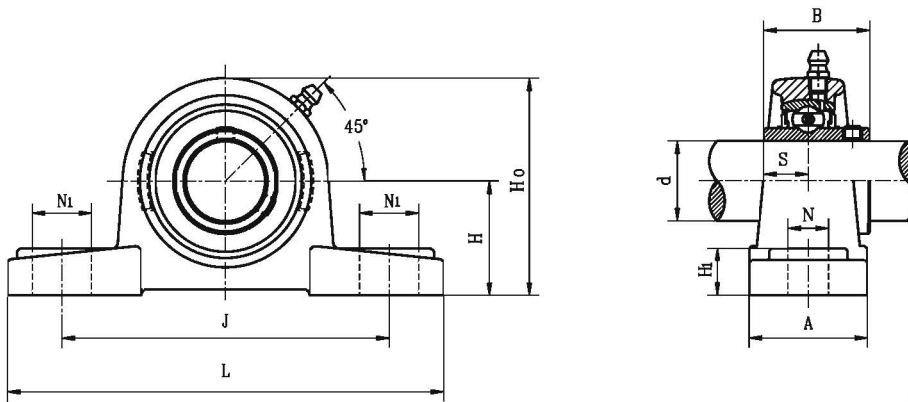

**UCPK2**  
Setscrew type

Unit No.	Shaft Dia.		Dimensions(mm).										Bolt Size	Bearing No.	Housing No.	Mass (kg)	
	d (in.)	d (mm)	H	L	J	A	N	N <sub>1</sub>	H <sub>1</sub>	H <sub>0</sub>	S	B					
UCPK201S 201-8S 202S 202-10S 203S 203-11S		12													UC201S 201-8S 202S 202-10S 203-S 203-11S	PK203	0.56 0.55 0.54
	1/2	15	27	121	89	35	11	14	13	54	11.5	27.4	M10				
	5/8	17															
	11/16																
UCPK201 201-8 202 202-10 203 203-11 204-12 204		12													UC201 201-8 202 202-10 203 203-11 204-12 204	PK204	0.78 0.76 0.75 0.73
	1/2	15	31.8	128	98	38	11	14	14	63	12.7	31	M10				
	5/8	17															
	11/16 3/4	20															
UCPK205-14 205-15 205 205-16	7/8														UC205-14 205-15 205 205-16	PK205	0.93
	15/16	25	33.3	140	105	40	11	14	15	66.5	14.3	34	M10				
	1																
UCPK206-18 206 206-19 206-20	1- 1/8														UC206-18 206 206-19 206-20	PK206	1.26
	1- 3/16	30	39.7	160	121	44	14	19	17	79	15.9	38.1	M12				
	1- 1/4																
UCPK207-20 207-21 207-22 207 207-23	1- 1/4														UC207-20 207-21 207-22 207 207-23	PK207	1.74
	1- 5/16																
	1- 3/8	35	46	167	127	48	14	19	18	91	17.5	42.9	M12				
	1-7/16																
UCPK208-24 208-25 208	1- 1/2														UC208-24 208-25 208	PK208	2.21
	1- 9/16	40	49.2	181	140	52	14	19	19	98	19	49.2	M12				
UCPK209-26 209-27 209-28 209	1- 5/8														UC209-26 209-27 209-28 209	PK209	2.54
	1- 11/16																
	1- 3/4	45	52.4	189	146	54	14	19	20	105	19	49.2	M12				
UCPK210-30 210-31 210	1- 7/8														UC210-30 210-31 210	PK210	2.93
	1-15/16	50	55.6	203	159	57	14	19	21	111.5	19	51.6	M12				
UCPK211-32 211-34 211 211-35	2														UC211-32 211-34 211 211-35	PK211	3.92
	2- 1/8																
	2- 3/16	55	61.9	232	181	60	18	24	23	123	22.2	55.6	M16				
UCPK212-36 212 212-38 212-39	2- 1/4														UC212-36 212 212-38 212-39	PK212	4.88
	2- 3/8																
	2- 7/16	60	68.3	241	191	64	18	24	25	136	25.4	65.1	M16				
UCPK213-40 213	2- 1/2	65	68.3	248	194	70	18	29	27	141	25.4	65.1	M16	UC213-40 213	PK213	5.59	

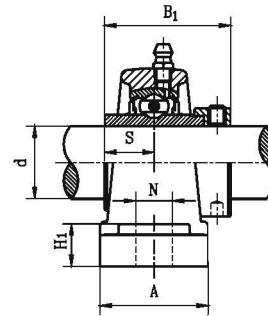
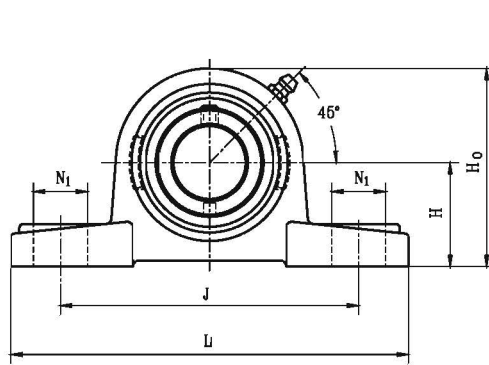

**NAPK2**  
Eccentric locking collar type

Unit No.	Shaft Dia.		Dimensions(mm).									Bolt Size	Bearing No.	Housing No.	Mass (kg)	
	d		H	L	J	A	N	N <sub>1</sub>	H <sub>1</sub>	H <sub>0</sub>	S					B <sub>1</sub>
	(in.)	(mm)														
NAPK201S 201-8S 202S 202-10S 203S 203-11S	1/2	12	27	121	89	35	11	14	13	54	13.9	37.3	M10	NA201S 201-8S 202S 202-10S 203S 203-11S	PK203	0.67 0.66 0.64
	5/8	15														
	11/16	17														
	11/16	17														
NAPK201 201-8 202 202-10 203 203-11 204-12 204	1/2	12	31.8	128	98	38	11	14	14	63	17	43.5	M10	NA201 201-8 202 202-10 203 203-11 204-12 204	PK204	0.85 0.82 0.81 0.78
	5/8	15														
	11/16	17														
	3/4	20														
	3/4	20														
NAPK 205-14 205-15 205 205-16	7/8	25	33.3	140	105	40	11	14	15	66.5	17.4	44.3	M10	NA205-14 205-15 205 205-16	PK205	0.98
	15/16	25														
	1	25														
	1	25														
NAPK 206-18 206 206-19 206-20	1- 1/8	30	39.7	160	121	44	14	19	17	79	18.2	48.3	M12	NA206-18 206 206-19 206-20	PK206	1.33
	1- 3/16	30														
	1- 1/4	30														
	1- 1/4	30														
NAPK 207-20 207-21 207-22 207 207-23	1- 1/4	35	46	167	127	48	14	19	18	91	18.8	51.1	M12	NA207-20 207-21 207-22 207 207-23	PK207	1.81
	1- 5/16															
	1- 3/8															
	1- 7/16															
	1- 7/16															
NAPK 208-24 208-25 208	1- 1/2	40	49.2	181	140	52	14	19	19	98	21.4	56.3	M12	NA208-24 208-25 208	PK208	2.32
	1- 9/16															
NAPK 209-26 209-27 209-28 209	1- 5/8	45	52.4	189	146	54	14	19	20	105	21.4	56.3	M12	NA209-26 209-27 209-28 209	PK209	2.66
	1- 11/16															
	1- 3/4															
	1- 3/4															
NAPK 210-30 210-31 210	1- 7/8	50	55.6	203	159	57	14	19	21	111.5	24.6	62.7	M12	NA210-30 210-31 210	PK210	3.10
	1- 15/16															
	1- 15/16															
NAPK 211-32 211-34 211 211-35	2	55	61.9	232	181	60	18	24	23	123	27.7	71.3	M16	NA211-32 211-34 211 211-35	PK211	4.17
	2- 1/8															
	2- 3/16															
	2- 3/16															
NAPK 212-36 212 212-38 212-39	2- 1/4	60	68.3	241	191	64	18	24	25	136	30.9	77.7	M16	NA212-36 212 212-38 212-39	PK212	5.16
	2- 3/8															
	2- 7/16															
	2- 7/16															
NAPK 213-40 213	2- 1/2	65	68.3	248	194	70	18	29	27	141	34.1	85.7	M16	NA213-40 213	PK213	5.98
	2- 1/2															

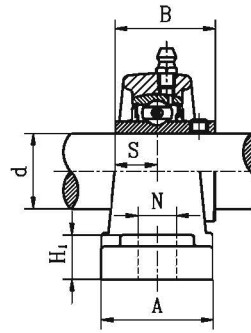
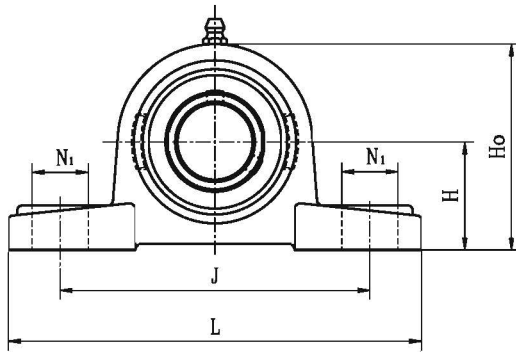

UCPX  
Setscrew type

Unit No.	Shaft Dia.		Dimensions(mm).										Bolt Size	Bearing No.	Housing No.	Mass (kg)
	d		H	L	J	A	N	N <sub>1</sub>	H <sub>1</sub>	H <sub>o</sub>	S	B				
	(in.)	(mm)														
UCPX05-14 X05-15 X05 X05-16	7/8 15/16 1	25	44.4	159	119	51	17	20	17	85	15.9	38.1	M14	UCX05-14 X05-15 X05 X05-16	PX05	1.48
UCPX06-18 X06 X06-19 X06-20	1-1/8 1-3/16 1-1/4	30	47.6	175	127	54	17	20	20	93	17.5	42.9	M14	UCX06-18 X06 X06-19 X06-20	PX06	1.86
UCPX07-22 X07 X07-23	1-3/8 1-7/16	35	54	203	144	57	17	20	21	105	19	49.2	M14	UCX07-22 X07 X07-23	PX07	2.63
UCPX08-24 X08	1-1/2	40	58.7	222	156	65	20	23	23	112	19	49.2	M16	UCX08-24 X08	PX08	3.19
UCPX09-26 X09-27 X09-28 X09	1-5/8 1-11/16 1-3/4	45	58.7	222	156	67	20	23	25	116	19	51.6	M16	UCX09-26 X09-27 X09-28 X09	PX09	3.36
UCPX10-30 X10-31 X10 X10-32	1-7/8 1-15/16	50	63.5	240	171	71	20	23	24	126	22.2	55.6	M16	UCX10-30 X10-31 X10 X10-32	PX10	4.12
UCPX11-34 X11 X11-35 X11-36	2-1/8 2-3/16 2-1/4	55	69.8	260	184	79	25	28	29	137	25.4	65.1	M20	UCX11-34 X11 X11-35 X11-36	PX11	5.55
UCPX12 X12-38 X12-39	2-3/8 2-7/16	60	76.2	280	203	81	25	28	31	149	25.4	65.1	M20	UCX12 X12-38 X12-39	PX12	6.79
UCPX13-40 X13	2-1/2	65	76.2	286	203	83	25	28	33	152	30.2	74.6	M20	UCX13-40 X13	PX13	7.38
UCPX14-44 X14	2-3/4	70	88.9	320	229	85	27	30	34	170	33.3	77.8	M22	UCX14-44 X14	PX14	9.63
UCPX15 X15-48	3	75	88.9	330	229	92	27	30	35	175	33.3	82.6	M22	UCX15 X15-48	PX15	10.7
UCPX16		80	101.6	378	283	99	27	30	37	194	34.1	85.7	M22	UCX16	PX16	15.0
UCPX17-52 X17	3-1/4	85	101.6	380	283	102	27	30	40	200	39.7	96	M22	UCX17-52 X17	PX17	16.5
UCPX18-56 X18	3-1/2	90	101.6	381	283	106	27	30	40	206	42.9	104	M22	UCX18-56 X18	PX18	18.2
UCPX20 X20-64	4	100	127	432	337	120	33	36	45	244	49.2	117.5	M27	UCX20 X20-64	PX20	28.2



# PILLOW BLOCKS

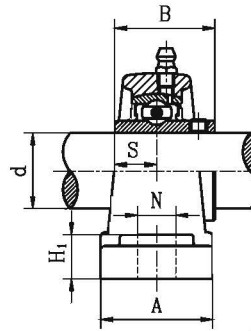
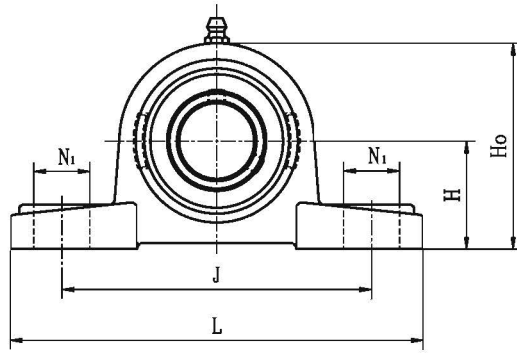

UCP3  
Setscrew type

Unit No.	Shaft Dia.		Dimensions(mm).										Bolt Size	Bearing No.	Housing No.	Mass (kg)
	d		H	L	J	A	N	N <sub>1</sub>	H <sub>1</sub>	H <sub>o</sub>	S	B				
	(in.)	(mm)														
UCP305-14 305-15 305 305-16	7/8 15/16 1	25	45	173	132	45	17	20	15	85	15	38	M14	UC305-14 305-15 305 305-16	P305	1.46
UCP306-18 306 306-19	1- 1/8 1- 3/16	30	50	180	140	49	17	20	16	95	17	43	M14	UC306-18 306 306-19	P306	1.80
UCP307-20 307-21 307-22 307	1- 1/4 1- 5/16 1- 3/8	35	56	210	160	56	17	25	19	106	19	48	M14	UC307-20 307-21 307-22 307	P307	2.98
UCP308-24 308-25 308	1- 1/2 1- 9/16	40	60	218	170	62	18	25	19	116	19	52	M14	UC308-24 308-25 308	P308	3.33
UCP309-26 309-27 309-28 309	1- 5/8 1-11/16 1- 3/4	45	67	244	190	66	20	26	23	129	22	57	M16	UC309-26 309-27 309-28 309	P309	4.41
UCP310-30 310-31 310	1- 7/8 1-15/16	50	75	271	212	74	20	30	26	143	22	61	M16	UC310-30 310-31 310	P310	6.10
UCP311-32 311-34 311 311-35	2 2-1/8 2-3/16	55	80	300	236	80	20	32	29	154	25	66	M16	UC311-32 311-34 311 311-35	P311	7.65
UCP312-36 312 312-38 312-39	2-1/4 2-3/8 2-7/16	60	85	325	250	85	23	35	31	164	26	71	M20	UC312-36 312 312-38 312-39	P312	9.20
UCP313-40 313	2- 1/2	65	90	335	260	90	25	38	33	176	30	75	M20	UC313-40 313	P313	11.3
UCP314-44 314	2-3/4	70	95	360	280	93	27	40	34	187	31	78	M22	UC314-44 314	P314	13.0
UCP315 315-48	3	75	100	380	290	100	27	40	35	198	32	82	M22	UC315 315-48	P315	15.9
UCP316		80	106	400	300	105	27	40	37	210	34	86	M22	UC316	P316	17.7
UCP317-52 317	3- 1/4	85	112	420	320	110	33	45	40	220	40	96	M27	UC317-52 317	P317	20.5
UCP318-56 318	3-1/2	90	118	430	330	110	33	45	45	235	40	96	M27	UC318-56 318	P318	25.1
UCP319 319-60	3-3/4	95	125	470	360	120	36	50	45	250	41	103	M30	UC319 319-60	P319	31.8
UCP320 320-64	4	100	140	490	380	120	36	50	50	275	42	108	M30	UC320 320-64	P320	37.2
UCP322		110	150	520	400	140	40	55	55	300	46	117	M33	UC322	P322	50.6
UCP324		120	160	570	450	140	40	55	65	320	51	126	M33	UC324	P324	54.5
UCP326		130	180	600	480	140	40	55	75	355	54	135	M33	UC326	P326	68.4
UCP328		140	200	620	500	140	40	55	75	390	59	145	M33	UC328	P328	82.1

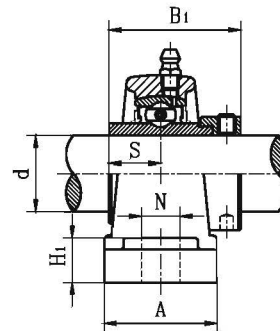
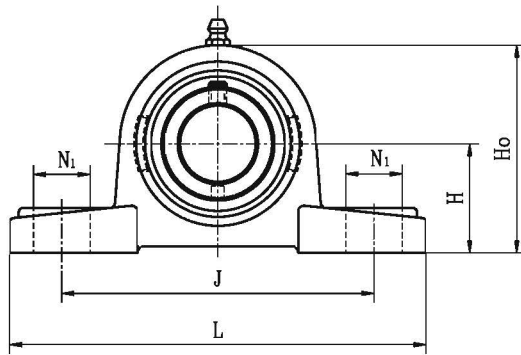

**NAP3**  
Eccentric locking collar type

Unit No.	Shaft Dia.		Dimensions(mm).										Bolt Size	Bearing No.	Housing No.	Mass (kg)
	d		H	L	J	A	N	N <sub>1</sub>	H <sub>1</sub>	Ho	S	B <sub>1</sub>				
	(in.)	(mm)														
NAP305-14 305-15 305 305-16	7/8 15/16 1	25	45	173	132	45	17	20	15	85	16.7	46.8	M14	NA305-14 305-15 305 305-16	P305	1.53
NAP306-18 306 306-19	1-1/8 1-3/16	30	50	180	140	49	17	20	16	95	17.5	50	M14	NA306-18 306 306-19	P306	1.94
NAP307-20 307-21 307-22 307	1-1/4 1-5/16 1-3/8	35	56	210	160	56	17	25	19	106	18.3	51.6	M14	NA307-20 307-21 307-22 307	P307	3.08
NAP308-24 308-25 308	1-1/2 1-9/16	40	60	218	170	62	18	25	19	116	19.8	57.1	M14	NA308-24 308-25 308	P308	3.47
NAP309-26 309-27 309-28 309	1-5/8 1-11/16 1-3/4	45	67	244	190	66	20	26	23	129	19.8	58.7	M16	NA309-26 309-27 309-28 309	P309	4.54
NAP310-30 310-31 310	1-7/8 1-15/16	50	75	271	212	74	20	30	26	143	24.6	66.6	M16	NA310-30 310-31 310	P310	6.32
NAP311-32 311-34 311 311-35	2 2-1/8 2-3/16	55	80	300	236	80	20	32	29	154	27.8	73	M16	NA311-32 311-34 311 311-35	P311	7.90
NAP312-36 312 312-38 312-39	2-1/4 2-3/8 2-7/16	60	85	325	250	85	23	35	31	164	30.95	79.4	M20	NA312-36 312 312-38 312-39	P312	9.51
NAP313-40 313	2-1/2	65	90	335	260	90	25	38	33	176	32.5	85.7	M20	NA313-40 313	P313	11.8
NAP314-44 314	2-3/4	70	95	360	280	93	27	40	34	187	34.15	92.1	M22	NA314-44 314	P314	13.6
NAP315 315-48	3	75	100	380	290	100	27	40	35	198	37.3	100	M22	NA315 315-48	P315	16.8
NAP316		80	106	400	300	105	27	40	37	210	40.5	106.4	M22	NA316	P316	18.9
NAP317-52 317	3-1/4	85	112	420	320	110	33	45	40	220	42	109.5	M27	NA317-52 317	P317	21.5
NAP318-56 318	3-1/2	90	118	430	330	110	33	45	45	235	43.6	115.9	M27	NA318-56 318	P318	26.5
NAP319 319-60	3-3/4	95	125	470	360	120	36	50	45	250	46.8	122.3	M30	NA319 319-60	P319	33.2
NAP320 320-64	4	100	140	490	380	120	36	50	50	275	50	128.6	M30	NA320 320-64	P320	39.6

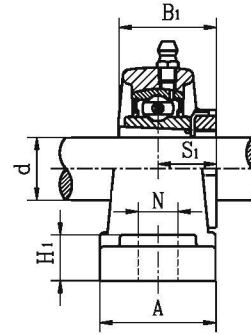
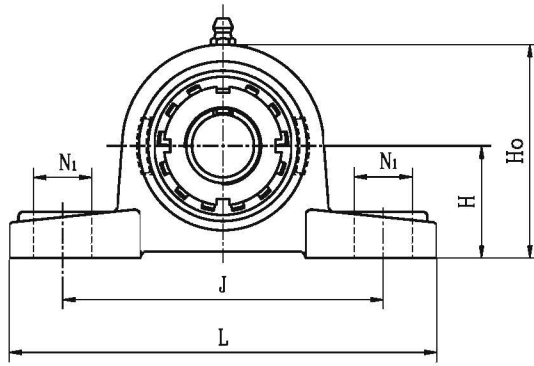

**UKP3+H**  
Tapered bore, adapter type

Unit No.	Shaft Dia.		Dimensions(mm).										Bolt Size	Bearing No.	Housing No.	Adapter No.	Mass (kg)
	d		H	L	J	A	N	N <sub>1</sub>	H <sub>1</sub>	H <sub>o</sub>	S <sub>1</sub>	B <sub>1</sub>					
	(in.)	(mm)															
UKP305+HE2305 305+H2305	3/4	20	45	173	132	45	17	20	15	85	21.5	35	M14	UK305	P305	HE2305 H2305	1.51
UKP306+HS2306 306+HA2306 306+H2306 306+HE2306	7/8 15/16 1	25	50	180	140	49	17	20	16	95	23	38	M14	UK306	P306	HS2306 HA2306 H2306 HE2306	1.85
UKP307+HS2307 307+H2307 307+HA2307	1-1/8 1-3/16	30	56	210	160	56	17	25	19	106	25.5	43	M14	UK307	P307	HS2307 H2307 HA2307	3.02
UKP308+HE2308 308+HS2308 308+H2308	1-1/4 1-3/8	35	60	218	170	62	18	25	19	116	27.5	46	M14	UK308	P308	HE2308 HS2308 H2308	3.38
UKP309+HA2309 309+HE2309 309+H2309	1-7/16 1-1/2	40	67	244	190	66	20	26	23	129	30	50	M16	UK309	P309	HA2309 HE2309 H2309	4.55
UKP310+HS2310 310+HA2310 310+HE2310 310+H2310	1-5/8 1-11/16 1-3/4	45	75	271	212	74	20	30	26	143	32	55	M16	UK310	P310	HS2310 HA2310 HE2310 H2310	6.14
UKP311+HS2311 311+HA2311 311+H2311 311+HE2311	1-7/8 1-15/16 2	50	80	300	236	80	20	32	29	154	33.5	59	M16	UK311	P311	HS2311 HA2311 H2311 HE2311	7.67
UKP312+HS2312 312+H2312	2-1/8	55	85	325	250	85	23	35	31	164	36.5	62	M20	UK312	P312	HS2312 H2312	9.20
UKP313+HA2313 313+HE2313 313+H2313 313+HS2313	2-3/16 2-1/4 2-3/8	60	90	335	260	90	25	38	33	176	38.5	65	M20	UK313	P313	HA2313 HE2313 H2313 HS2313	11.2
UKP315+HA2315 315+HE2315 315+H2315	2-7/16 2-1/2	65	100	380	290	100	27	40	35	198	42.5	73	M22	UK315	P315	HA2315 HE2315 H2315	16.2
UKP316+HA2316 316+HE2316 316+H2316	2-11/16 2-3/4	70	106	400	300	105	27	40	37	210	44.5	78	M22	UK316	P316	HA2316 HE2316 H2316	18.0
UKP317+HA2317 317+H2317 317+HE2317	2-15/16 3	75	112	420	320	110	33	45	40	220	48	82	M27	UK317	P317	HA2317 H2317 HE2317	20.5
UKP318+H2318		80	118	430	330	110	33	45	45	235	48	86	M27	UK318	P318	H2318	25.2
UKP319+HE2319 319+H2319	3-1/4	85	125	470	360	120	36	50	45	250	52	90	M30	UK319	P319	HE2319 H2319	31.6
UKP320+HE2320 320+H2320	3-1/2	90	140	490	380	120	36	50	50	275	54	97	M30	UK320	P320	HE2320 H2320	37.2
UKP322+H2322		100	150	520	400	140	40	55	55	300	61	105	M33	UK322	P322	H2322	50.6
UKP324+H2324		110	160	570	450	140	40	55	65	320	65.5	112	M33	UK324	P324	H2324	54.1
UKP326+H2326		115	180	600	480	140	40	55	75	355	68	121	M33	UK326	P326	H2326	68.2
UKP328+H2328		125	200	620	500	140	40	55	75	390	73	131	M33	UK328	P328	H2328	81.9





# LIGHT-DUTY PILLOW BLOCKS (LP2 TYPE)

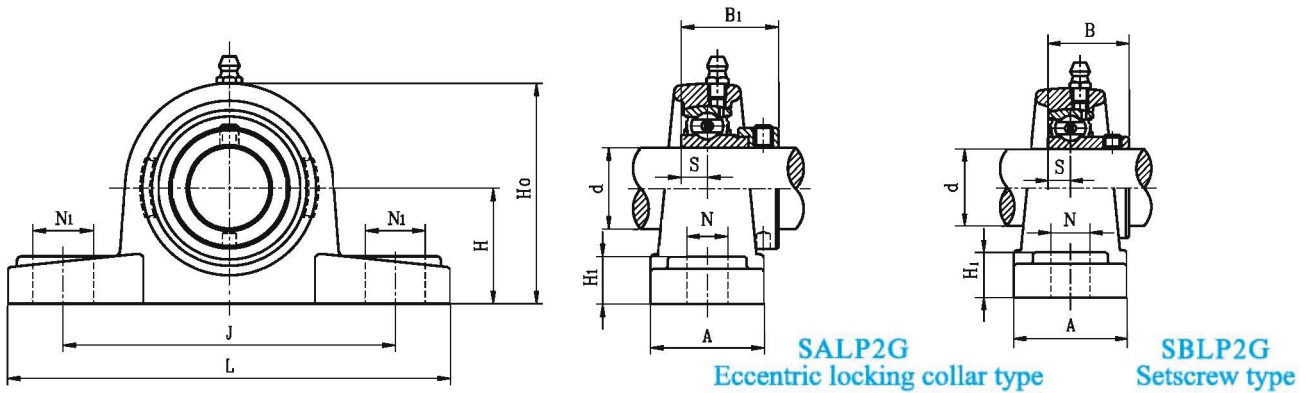

Unit No.	Shaft Dia.		Dimensions(mm).									Bolt Size	Bearing No.	Housing No.	Mass (kg)	
	d (in.)	d (mm)	H	L	J	A	H <sub>0</sub>	N	N <sub>1</sub>	H <sub>1</sub>	S					B <sub>1</sub>
SALP201G 201-8G 202G 202-10G 203G 203-11G	1/2 5/8 11/16	12 15 17	30.2	114	87	25	57	11	16	12	6.5	28.6	M10	SA201G 201-8G 202G 202-10G 203G 203-11G	LP203	0.46 0.45 0.43
SALP204-12G 204G	3/4	20	33.3	125	97	27	63.8	11.5	16	14	7.5	30.9	M10	SA204-12G 204G	LP204	0.60
SALP205-14G 205-15G 205G 205-16G	7/8 15/16 1	25	36.5	130	100	29	69.5	11.5	16	15	7.5	30.9	M10	SA205-14G 205-15G 205G 205-16G	LP205	0.72
SALP206-18G 206G 206-19G 206-20G	1- 1/8 1- 3/16 1- 1/4	30	42.9	156	121	33	82	14	21	16	9	35.7	M12	SA206-18G 206G 206-19G 206-20G	LP206	1.03
SALP207-20G 207-21G 207-22G 207G 207-23G	1- 1/4 1- 5/16 1- 3/8 1- 7/16	35	47.6	165	127	35	93	14	21	16	9.5	38.9	M12	SA207-20G 207-21G 207-22G 207G 207-23G	LP207	1.4

Unit No.	Shaft Dia.		Dimensions(mm).									Bolt Size	Bearing No.	Housing No.	Mass (kg)	
	d (in.)	d (mm)	H	L	J	A	H <sub>0</sub>	N	N <sub>1</sub>	H <sub>1</sub>	S					B
SBLP201G 201-8G 202G 202-10G 203G 203-11G	1/2 5/8 11/16	12 15 17	30.2	114	87	25	57	11	16	12	6	22	M10	SB201G 201-8G 202G 202-10G 203G 203-11G	LP203	0.44 0.43 0.42
SBLP204-12G 204G	3/4	20	33.3	125	97	27	63.8	11.5	16	14	7	25	M10	SB204-12G 204G	LP204	0.57
SBLP205-14G 205-15G 205G 205-16G	7/8 15/16 1	25	36.5	130	100	29	69.5	11.5	16	15	7.5	27	M10	SB205-14G 205-15G 205G 205-16G	LP205	0.70
SBLP206-18G 206G 206-19G 206-20G	1- 1/8 1- 3/16 1- 1/4	30	42.9	156	121	33	82	14	21	16	8	30	M12	SB206-18G 206G 206-19G 206-20G	LP206	0.98
SBLP207-20G 207-21G 207-22G 207G 207-23G	1- 1/4 1- 5/16 1- 3/8 1- 7/16	35	47.6	165	127	35	93	14	21	16	8.5	32	M12	SB207-20G 207-21G 207-22G 207G 207-23G	LP207	1.34

Remarks: The numbers indicate relubricatable type. If maintenance free type is needed, please order without suffix "G".



# HIGH CENTER HEIGHT PILLOW BLOCKS

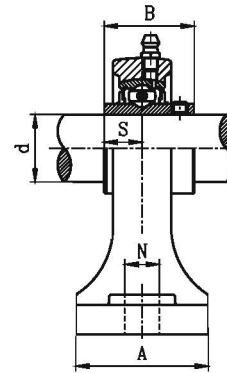
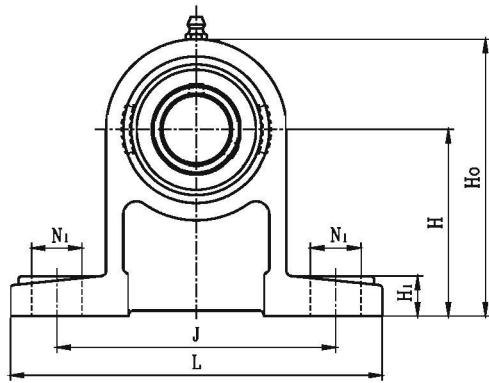

UCPH2  
Setscrew type

Unit No.	Shaft Dia.		Dimensions(mm).										Bolt Size	Bearing No.	Housing No.	Mass (kg)	
	d		H	J	L	A	N	N <sub>1</sub>	H <sub>1</sub>	H <sub>o</sub>	S	B					
	(in.)	(mm)															
UCPH201S 201-8S 202S 202-10S 203S 203-11S	1/2	12	70	95	127	38	12	16	13	97	11.5	27.4	M10	UC201S 201-8S 202S 202-10S 203S 203-11S	PH203	0.62	
	5/8	15															0.61
		17															0.60
	11/16																
UCPH201 201-8 202 202-10 203 203-11 204-12 204	1/2	12	70	95	127	40	12	16	13	101	12.7	31	M10	UC201 201-8 202 202-10 203 203-11 204-12 204	PH204	0.78	
	5/8	15															0.76
		17															0.75
	11/16																
	3/4	20															0.73
UCPH205-14 205-15 205 205-16	7/8		80	105	140	50	13	19	16	114	14.3	34	M10	UC205-14 205-15 205 205-16	PH205	1.06	
	15/16	25															
	1																
UCPH206-18 206 206-19 206-20	1-1/8		90	121	165	50	17	21	18	130	15.9	38.1	M14	UC206-18 206 206-19 206-20	PH206	1.49	
	1-3/16	30															
	1-1/4																
UCPH207-20 207-21 207-22 207 207-23	1-1/4		95	127	167	60	17	21	19	140	17.5	42.9	M14	UC207-20 207-21 207-22 207 207-23	PH207	1.91	
	1-5/16																
	1-3/8	35															
	1-7/16																
UCPH208-24 208-25 208	1-1/2		100	137	184	66	17	21	20	150	19	49.2	M14	UC208-24 208-25 208	PH208	2.42	
	1-9/16	40															
UCPH209-26 209-27 209-28 209	1-5/8		105	146	190	70	17	21	20	158	19	49.2	M14	UC209-26 209-27 209-28 209	PH209	2.84	
	1-11/16																
	1-3/4	45															
UCPH210-30 210-31 210 210-32	1-7/8		110	159	204	70	19	22	22	165	19	51.6	M16	UC210-30 210-31 210 210-32	PH210	3.09	
	1-15/16	50															
	2																
UCPH211-32 211-34 211 211-35	2		120	171	217	75	19	22	23	181	22.2	55.6	M16	UC211-32 211-34 211 211-35	PH211	3.97	
	2-1/8	55															
	2-3/16																
UCPH212-36 212 212-38 212-39	2-1/4		130	186	236	80	19	22	24	197	25.4	65.1	M16	UC212-36 212 212-38 212-39	PH212	5.10	
	2-3/8	60															
	2-7/16																
UCPH213-40 213	2-1/2		140	203	258	85	23	28	26	213	25.4	65.1	M20	UC213-40 213	PH213	6.26	
UCPH214-44 214	2-3/4		150	210	266	90	23	28	27	227	30.2	74.6	M20	UC214-44 214	PH214	7.35	
UCPH215-47 215 215-48	2-15/16		160	217	274	95	23	28	28	240	33.3	77.8	M20	UC215-47 215 215-48	PH215	8.10	
		75															
	3																
UCPH216			80	170	232	290	100	24	28	30	256	33.3	82.6	M20	UC216	PH216	9.77



# TAPPED -BASE PILLOW BLOCKS

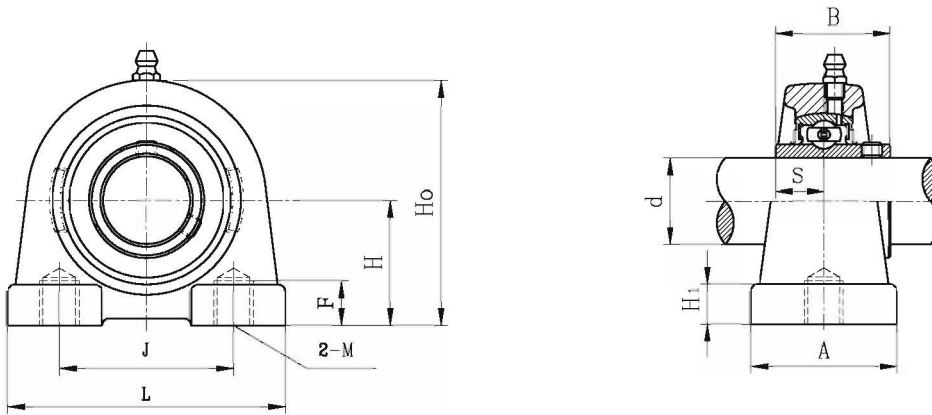

UCPA2  
Setscrew type

Unit No.	Shaft Dia.		Dimensions(mm).										Bearing No.	Housing No.	Mass (kg)
	d		H	L	J	A	H <sub>0</sub>	H <sub>1</sub>	S	B	F	M			
	(in.)	(mm)													
UCPA201S 201-8S 202S 202-10S 203S 203-11S	1/2 5/8 11/16	12 15 17	30.2	70	48	36	57	10	11.5	27.4	9	M8	UC201S 201-8S 202S 202-10S 203S 203-11S	PA203	0.41 0.40 0.39
UCPA201 201-8 202 202-10 203 203-11 204-12 204	1/2 5/8 11/16 3/4	12 15 17 20	30.2	76	52	40	62	11	12.7	31	13	M10	UC201 201-8 202 202-10 203 203-11 204-12 204	PA204	0.61 0.59 0.58 0.56
UCPA205-14 205-15 205 205-16	7/8 15/16 1	25	36.5	84	56	38	72	12	14.3	34	15	M10	UC205-14 205-15 205 205-16	PA205	0.75
UCPA206-18 206 206-19 206-20	1- 1/8 1- 3/16 1- 1/4	30	42.9	94	66	48	84	13	15.9	38.1	18	M14	UC206-18 206 206-19 206-20	PA206	1.11
UCPA207-20 207-21 207-22 207 207-23	1- 1/4 1- 5/16 1- 3/8 1-7/16	35	47.6	110	80	48	95	13	17.5	42.9	20	M14	UC207-20 207-21 207-22 207 207-23	PA207	1.51
UCPA208-24 208-25 208	1- 1/2 1- 9/16	40	49.2	116	84	54	100	13	19	49.2	20	M14	UC208-24 208-25 208	PA208	1.79
UCPA209-26 209-27 209-28 209	1- 5/8 1-11/16 1- 3/4	45	54.2	120	90	60	108	13	19	49.2	25	M14	UC209-26 209-27 209-28 209	PA209	2.16
UCPA210-30 210-31 210 210-32	1- 7/8 1-15/16 2	50	57.2	130	94	60	116	14	19	51.6	25	M16	UC210-30 210-31 210 210-32	PA210	2.65
UCPA211-32 211-34 211 211-35	2 2- 1/8 2- 3/16	55	63.5	140	104	66	125	14	22.2	55.6	25	M16	UC211-32 211-34 211 211-35	PA211	2.74
UCPA212-36 212 212-38 212-39	2- 1/4 2- 3/8 2- 7/16	60	69.9	150	114	68	138	15	25.4	65.1	25	M16	UC212-36 212 212-38 212-39	PA212	4.12
UCPA213-40 213	2- 1/2	65	76.2	160	124	70	150	15	25.4	65.1	25	M16	UC213-40 213	PA213	5.13



# TAPPED -BASE PILLOW BLOCKS

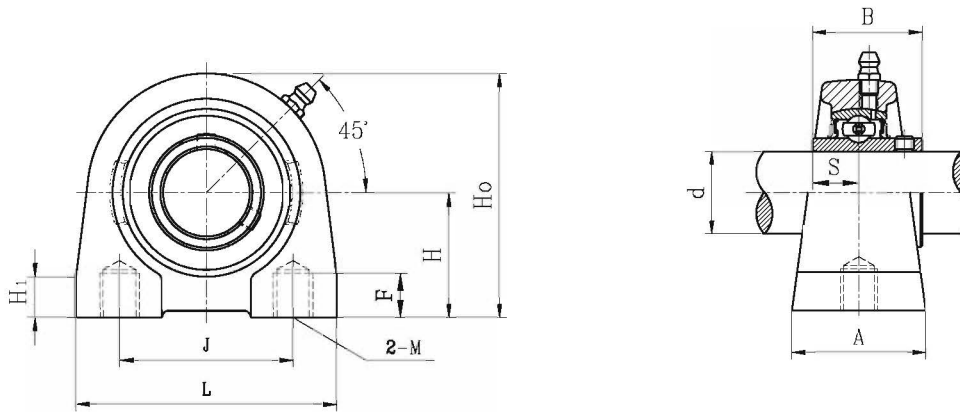

UCPA2A  
Setscrew type

Unit No.	Shaft Dia.		Dimensions(mm).									Bearing No.	Housing No.	Mass (kg)	Available	
	d		H	L	J	A	Ho	H1	S	B	F					M
	(in.)	(mm)														
UCPA201A 201-8A 202A 202-10A 203A 203-11A 204-12A 204A	1/2 5/8 11/16 3/4	12 15 17 20	33.3	73	50.8	38	65	12	12.7	31	13	M8	UC201 201-8 202 202-10 203 203-11 204-12 204	PA204A	0.65 0.63 0.62 0.60	3/8-16UNC
UCPA205-14A 205-15A 205A 205-16A	7/8 15/16 1	25	36.5	76.2	50.8	38	71.4	12	14.3	34	13	M10	UC205-14 205-15 205 205-16	PA205A	0.71	3/8-16UNC
UCPA206-18A 206A 206-19A 206-20A	1-1/8 1-3/16 1-1/4	30	42.9	101.6	76.2	38	85.7	15	15.9	38.1	16	M10	UC206-18 206 206-19 206-20	PA206A	1.15	7/16-14UNC
UCPA207-20A 207-21A 207-22A 207A 207-23A	1-1/4 1-5/16 1-3/8 1-7/16	35	47.6	108	82.5	47.6	95.2	16	17.5	42.9	19	M10	UC207-20 207-21 207-22 207 207-23	PA207A	1.64	1/2-13UNC
UCPA208-24A 208-25A 208A	1-1/2 1-9/16	40	49.2	117.5	88.9	47.6	100	16	19	49.2	19	M12	UC208-24 208-25 208	PA208A	1.78	1/2-13UNC
UCPA209-26A 209-27A 209-28A 209A	1-5/8 1-11/16 1-3/4	45	53.98	127	95.25	50.8	108	18	19	49.2	19	M12	UC209-26 209-27 209-28 209	PA209A	2.17	1/2-13UNC
UCPA210-30A 210-31A 210A 210-32A	1-7/8 1-15/16 2	50	57.15	139.7	101.6	50.8	117.5	18	19	51.6	25	M16	UC210-30 210-31 210 210-32	PA210A	2.68	5/8-11UNC



# TAPPED -BASE PILLOW BLOCKS

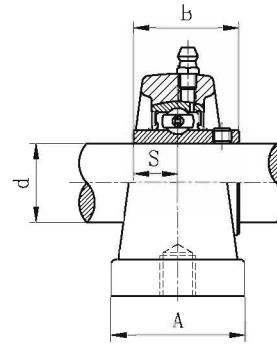
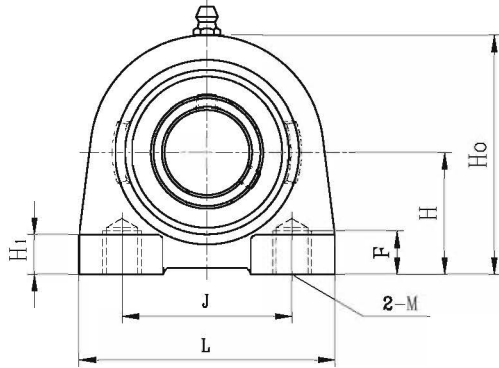

UCPG2  
Setscrew type

Unit No.	Shaft Dia.		Dimensions(mm).										Bearing No.	Housing No.	Mass (kg)
	d		H	L	J	A	Ho	H1	S	B	F	M			
	(in.)	(mm)													
UCPG 201 201-8 202 202-10 203 203-11 204-12 204	1/2 5/8 11/16 3/4	12 15 17 20	33.3	70	49	38	64	14	12.7	31	13	M8	UC201 201-8 202 202-10 203 203-11 204-12 204	PG204	0.65 0.63 0.62 0.60
UCPG 205-14 205-15 205 205-16	7/8 15/16 1	25	36.5	75	50	38	70	15	14.3	34	15	M10	UC 205-14 205-15 205 205-16	PG205	0.69
UCPG 206-18 206 206-19 206-20	1-1/8 1-3/16 1-1/4	30	42.9	85	60	48	83	17	15.9	38.1	15	M10	UC 206-18 206 206-19 206-20	PG206	1.09
UCPG 207-20 207-21 207-22 207 207-23	1-1/4 1-5/16 1-3/8 1-7/16	35	47.6	100	68	48	93	20	17.5	42.9	19	M12	UC 207-20 207-21 207-22 207 207-23	PG207	1.56
UCPG 208-24 208-25 208	1-1/2 1-9/16	40	49.2	110	78	54	98	20	19	49.2	19	M12	UC 208-24 208-25 208	PG208	1.83



# PRESSED HPUSING PILLOW BLOCKS

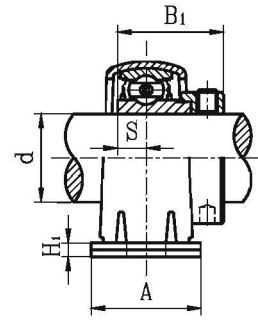
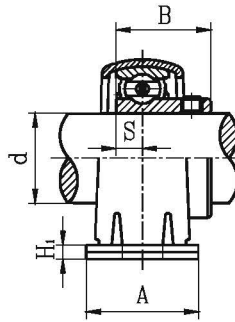
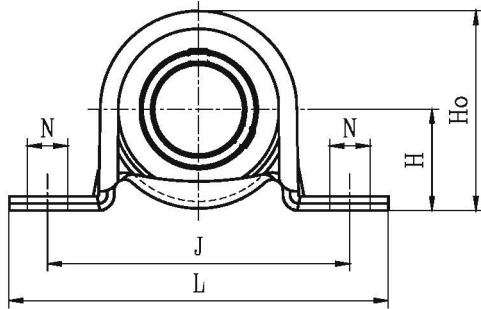

**SBPP2**  
Setscrew type

**SAPP2**  
Eccentric locking collar type

Unit No.	Shaft Dia.		Dimensions(mm).									Bolt Size	Bearing No.	Housing No.	Mass (kg)
	d (in.)	d (mm)	H	J	L	A	N	H <sub>1</sub>	H <sub>0</sub>	S	B				
SBPP201 201-8 202 202-10 203 203-11	1/2 5/8 11/16	12 15 17	22.2	68	86	25	9.5	3	43.5	6	22	M8	SB201 201-8 202 202-10 203 203-11	PP203	0.17 0.16 0.15
SBPP204-12 204	3/4	20	25.4	76	98	32	9.5	3	50.2	7	25	M8	SB204-12 204	PP204	0.21
SBPP205-14 205-15 205 205-16	7/8 15/16 1	25	28.6	86	108	32	11.5	4	56.4	7.5	27	M10	SB205-14 205-15 205 205-16	PP205	0.30
SBPP206-18 206 206-19 206-20	1-1/8 1-3/16 1-1/4	30	33.3	95	117	38	11.5	4	66.1	8	30	M10	SB206-18 206 206-19 206-20	PP206	0.42
SBPP207-20 207-21 207-22 207 207-23	1-1/4 1-5/16 1-3/8 1-7/16	35	39.7	106	129	42	11.5	4	77.7	8.5	32	M10	SB207-20 207-21 207-22 207 207-23	PP207	0.59

Unit No.	Shaft Dia.		Dimensions(mm).									Bolt Size	Bearing No.	Housing No.	Mass (kg)
	d (in.)	d (mm)	H	J	L	A	N	H <sub>1</sub>	H <sub>0</sub>	S	B <sub>1</sub>				
SAPP201 201-8 202 202-10 203 203-11	1/2 5/8 11/16	12 15 17	22.2	68	86	25	9.5	3	43.5	6.5	28.6	M8	SA201 201-8 202 202-10 203 203-11	PP203	0.19 0.18 0.16
SAPP204-12 204	3/4	20	25.4	76	98	32	9.5	3	50.2	7.5	30.9	M8	SA204-12 204	PP204	0.24
SAPP205-14 205-15 205 205-16	7/8 15/16 1	25	28.6	86	108	32	11.5	4	56.4	7.5	30.9	M10	SA205-14 205-15 205 205-16	PP205	0.32
SAPP206-18 206 206-19 206-20	1-1/8 1-3/16 1-1/4	30	33.3	95	117	38	11.5	4	66.1	9	35.7	M10	SA206-18 206 206-19 206-20	PP206	0.47
SAPP207-20 207-21 207-22 207 207-23	1-1/4 1-5/16 1-3/8 1-7/16	35	39.7	106	129	42	11.5	4	77.7	9.5	38.9	M10	SA207-20 207-21 207-22 207 207-23	PP207	0.65



# SQUARE FLANGE UNITS

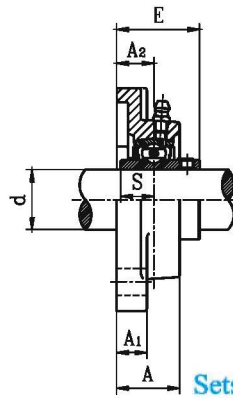
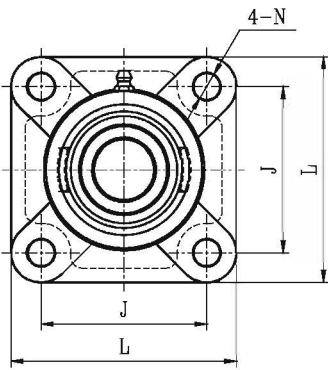

UCF2  
Setscrew type

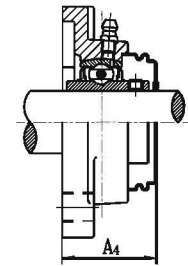

S-UCF200E1  
SM-UCF200E1  
With end cover

Unit No.	Shaft Dia.		Dimensions(mm).									Bolt Size	Bearing No.	Housing No.	Mass (kg)	Available N
	d (in.)	d (mm)	L	J	A <sub>2</sub>	A <sub>1</sub>	A	E	N	S	A <sub>4</sub>					
UCF201S 201-8S 202S 202-10S 203S 203-11S	1/2 5/8 11/16	12 15 17	76	54	15	11	24.5	30.9	11.5	11.5	--	M10	UC201S 201-8S 202S 202-10S 203S 203-11S	F203	0.39 0.38 0.37	--
UCF201 201-8 202 202-10 203 203-11 204-12 204	1/2 5/8 11/16 3/4	12 15 17 20	86	64	15	11	25.5	33.3	11.5	12.7	37.5	M10	UC201 201-8 202 202-10 203 203-11 204-12 204	F204	0.64 0.62 0.61 0.59	12
UCF205-14 205-15 205 205-16	7/8 15/16 1	25	95	70	16	13	27	35.7	11.5	14.3	40	M10	UC205-14 205-15 205 205-16	F205	0.78	12
UCF206-18 206 206-19 206-20	1-1/8 1-3/16 1-1/4	30	108	83	18	13	31	40.2	11.5	15.9	44	M10	UC206-18 206 206-19 206-20	F206	1.12	12
UCF207-20 207-21 207-22 207 207-23	1-1/4 1-5/16 1-3/8 1-7/16	35	117	92	19	15	34	44.4	14	17.5	48.5	M12	UC207-20 207-21 207-22 207 207-23	F207	1.54	--
UCF208-24 208-25 208	1-1/2 1-9/16	40	130	102	21	15	36	51.2	14	19	55	M12	UC208-24 208-25 208	F208	1.81	16
UCF209-26 209-27 209-28 209	1-5/8 1-11/16 1-3/4	45	137	105	22	16	38	52.2	16	19	57	M14	UC209-26 209-27 209-28 209	F209	2.02	--
UCF210-30 210-31 210	1-7/8 1-15/16	50	143	111	22	16	40	54.6	18	19	60	M16	UC210-30 210-31 210	F210	2.32	16
UCF211-32 211-34 211 211-35	2 2-1/8 2-3/16	55	162	130	25	18	43	58.4	18	22.2	64	M16	UC211-32 211-34 211 211-35	F211	3.07	19
UCF212-36 212 212-38 212-39	2-1/4 2-3/8 2-7/16	60	175	143	29	18	48	68.7	18	25.4	74.5	M16	UC212-36 212 212-38 212-39	F212	4.34	19
UCF213-40 213	2-1/2	65	187	149	30	22	50	69.7	18	25.4	79	M16	UC213-40 213	F213	4.91	19
UCF214-44 214	2-3/4	70	193	152	31	22	54	75.4	18	30.2	--	M16	UC214-44 214	F214	6.27	19
UCF215-47 215 215-48	2-15/16 3	75	200	159	34	22	56	78.5	18	33.3	--	M16	UC215-47 215 215-48	F215	6.33	19
UCF216		80	208	165	34	22	57	83.3	22	33.3	--	M20	UC216	F216	7.00	23
UCF217-52 217	3-1/4	85	220	175	36	24	63	87.6	23	34.1	--	M20	UC217-52 217	F217	8.69	--
UCF218-56 218	3-1/2	90	235	187	40	25	68	96.3	23	39.7	--	M20	UC218-56 218	F218	11.1	--
UCF220 220-64	4	100	265	210	44	25	70	110	27	42	--	M22	UC220 220-64	F220	14.8	--



# SQUARE FLANGE UNITS

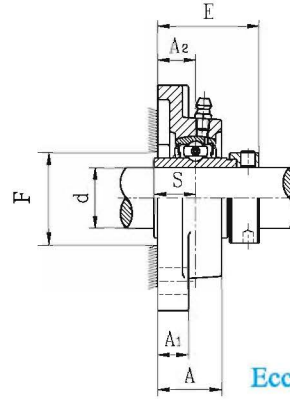
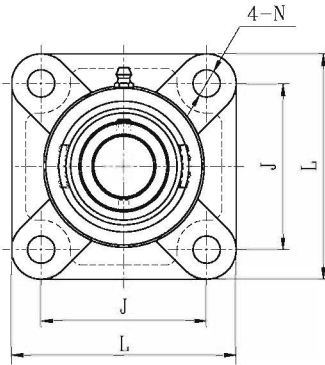

NAF2  
Eccentric locking collar type

Unit No.	Shaft Dia.		Dimensions(mm).									Bolt Size	Bearing No.	Housing No.	Mass (kg)	Available
	(in.)	(mm)	L	J	A <sub>2</sub>	A <sub>1</sub>	A	E	N	S	F <sub>min</sub>					
NAF201S 201-8S 202S 202-10S 203S 203-11S	1/2 5/8 11/16	12 15 17	76	54	15	11	24.5	38.4	11.5	13.9	--	M10	NA201S 201-8S 202S 202-10S 203S 203-11S	F203	0.50 0.49 0.47	--
NAF201 201-8 202 202-10 203 203-11 204-12 204	1/2 5/8 11/16 3/4	12 15 17 20	86	64	15	11	25.5	41.5	11.5	17	31	M10	NA201 201-8 202 202-10 203 203-11 204-12 204	F204	0.71 0.68 0.67 0.64	12
NAF205-14 205-15 205 205-16	7/8 15/16 1	25	95	70	16	13	27	42.9	11.5	17.4	36	M10	NA205-14 205-15 205 205-16	F205	0.83	12
NAF206-18 206 206-19 206-20	1-1/8 1-3/16 1-1/4	30	108	83	18	13	31	48.1	11.5	18.2	42	M10	NA206-18 206 206-19 206-20	F206	1.19	12
NAF207-20 207-21 207-22 207 207-23	1-1/4 1-5/16 1-3/8 1-7/16	35	117	92	19	15	34	51.3	14	18.8	50	M12	NA207-20 207-21 207-22 207 207-23	F207	1.61	--
NAF208-24 208-25 208	1-1/2 1-9/16	40	130	102	21	15	36	55.9	14	21.4	55	M12	NA208-24 208-25 208	F208	1.92	16
NAF209-26 209-27 209-28 209	1-5/8 1-11/16 1-3/4	45	137	105	22	16	38	56.9	16	21.4	--	M14	NA209-26 209-27 209-28 209	F209	2.14	--
NAF210-30 210-31 210	1-7/8 1-15/16	50	143	111	22	16	40	60.1	18	24.6	64	M16	NA210-30 210-31 210	F210	2.49	16
NAF211-32 211-34 211 211-35	2 2-1/8 2-3/16	55	162	130	25	18	43	68.6	18	27.7	71	M16	NA211-32 211-34 211 211-35	F211	3.32	19
NAF212-36 212 212-38 212-39	2-1/4 2-3/8 2-7/16	60	175	143	29	18	48	75.8	18	30.9	77	M16	NA212-36 212 212-38 212-39	F212	4.62	19
NAF213-40 213	2-1/2	65	187	149	30	22	50	81.6	18	34.1	84	M16	NA213-40 213	F213	5.30	19
NAF214-44 214	2-3/4	70	193	152	31	22	54	82.6	18	34.1	89	M16	NA214-44 214	F214	6.31	19
NAF215 215-48	3	75	200	159	34	22	56	88.8	18	37.3	94	M16	NA215 215-48	F215	6.79	19
NAF216		80	208	165	34	22	57	91.9	22	37.3	101	M20	NA216	F216	7.62	23
NAF217-52 217	3-1/4	85	220	175	36	24	63	85.8	23	23.4	--	M20	NA217-52 217	F217	8.90	
NAF218-56 218	3-1/2	90	235	187	40	25	68	88	23	24.5	--	M20	NA218-56 218	F218	10.8	
NAF220		100	265	210	44	25	70	119.4	27	50	129	M22	NA220	F220	16.1	



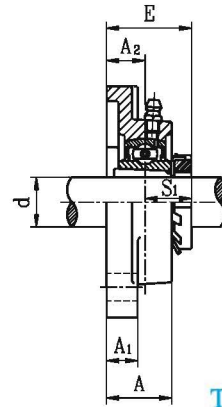
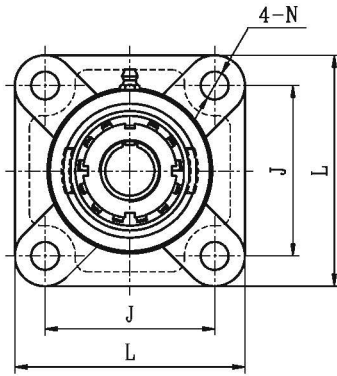

**UKF2+H**  
Tapered bore, adapter type

Unit No.	Shaft Dia.		Dimensions(mm).								Bolt Size	Bearing No.	Housing No.	Adapter No.	Mass (kg)	Available
	d (in.)	d (mm)	L	J	A <sub>2</sub>	A <sub>1</sub>	A	E	N	S <sub>1</sub>						
UKF205+HE2305 205+H2305	3/4	20	95	70	16	13	27	34.5	11.5	18.5	M10	UK205	F205	HE2305 H2305	0.82	12
UKF206+HS2306 206+HA2306 206+H2306 206+HE2306	7/8 15/16 1	25	108	83	18	13	31	38.5	11.5	20.5	M10	UK206	F206	HS2306 HA2306 H2306 HE2306	1.19	12
UKF207+HS2307 207+H2307 207+HA2307	1-1/8 1-3/16	30	117	92	19	15	34	41.5	14	22.5	M12	UK207	F207	HS2307 H2307 HA2307	1.59	--
UKF208+HE2308 208+HS2308 208+H2308	1-1/4 1-3/8	35	130	102	21	15	36	45.5	14	24.5	M12	UK208	F208	HE2308 HS2308 H2308	1.87	16
UKF209+HA2309 209+HE2309 209+H2309	1-7/16 1-1/2	40	137	105	22	16	38	48	16	26	M14	UK209	F209	HA2309 HE2309 H2309	2.13	--
UKF210+HS2310 210+HA2310 210+HE2310 210+H2310	1-5/8 1-11/16 1-3/4	45	143	111	22	16	40	49.5	18	27.5	M16	UK210	F210	HS2310 HA2310 HE2310 H2310	2.50	16
UKF211+HS2311 211+HA2311 211+H2311 211+HE2311	1-7/8 1-15/16 2	50	162	130	25	18	43	53.5	18	28.5	M16	UK211	F211	HS2311 HA2311 H2311 HE2311	3.23	19
UKF212+HS2312 212+H2312	2-1/8	55	175	143	29	18	48	60	18	31	M16	UK212	F212	HS2312 H2312	4.44	19
UKF213+HA2313 213+HE2313 213+H2313 213+HS2313	2-3/16 2-1/4 2-3/8	60	187	149	30	22	50	62	18	32	M16	UK213	F213	HA2313 HE2313 H2313 HS2313	4.99	19
UKF215+HA2315 215+HE2315 215+H2315	2-7/16 2-1/2	65	200	159	34	22	56	69.5	18	35.5	M16	UK215	F215	HA2315 HE2315 H2315	6.70	19
UKF216+HA2316 216+HE2316 216+H2316	2-11/16 2-3/4	70	208	165	34	22	57	73	22	39	M20	UK216	F216	HA2316 HE2316 H2316	7.47	23
UKF217+HA2317 217+H2317 217+HE2317	2-15/16 3	75	220	175	36	24	63	76	23	40	M20	UK217	F217	HA2317 H2317 HE2317	9.08	--
UKF218+H2318		80	235	187	40	25	68	82	23	42	M20	UK218	F218	H2318	11.5	--



# SQUARE FLANGE UNITS

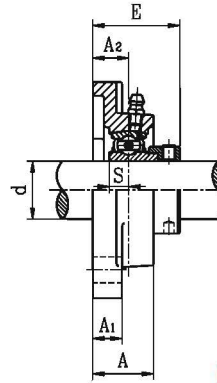
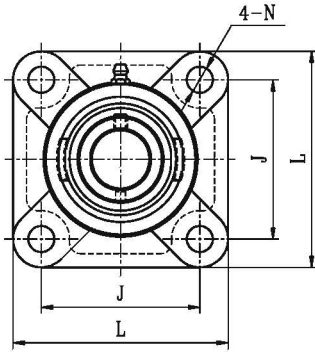

**SAF2G**  
Eccentric locking collar type

Unit No.	Shaft Dia.		Dimensions(mm).								Bolt Size	Bearing No.	Housing No.	Mass (kg)	Available
	d (in.)	d (mm)	L	J	A <sub>2</sub>	A <sub>1</sub>	A	E	N	S					
SAF201G 201-8G 202G 202-10G 203G 203-11G	1/2 5/8 11/16	12 15 17	76	54	15	11	24.5	37.1	11.5	6.5	M10	SA201G 201-8G 202G 202-10G 203G 203-11G	F203	0.40 0.39 0.37	--
SAF204-12G 204G	3/4	20	86	64	15	11	25.5	38.4	11.5	7.5	M10	SA204-12G 204G	F204	0.59	12
SAF205-14G 205-15G 205G 205-16G	7/8 15/16 1	25	95	70	16	13	27	39.4	11.5	7.5	M10	SA205-14G 205-15G 205G 205-16G	F205	0.77	12
SAF206-18G 206G 206-19G 206-20G	1-1/8 1-3/16 1-1/4	30	108	83	18	13	31	44.7	11.5	9	M10	SA206-18G 206G 206-19G 206-20G	F206	1.11	12
SAF207-20G 207-21G 207-22G 207G 207-23G	1-1/4 1-5/16 1-3/8 1-7/16	35	117	92	19	15	34	48.4	14	9.5	M12	SA207-20G 207-21G 207-22G 207G 207-23G	F207	1.51	--
SAF208-24G 208-25G 208G	1-1/2 1-9/16	40	130	102	21	15	36	53.7	14	11	M12	SA208-24G 208-25G 208G	F208	1.79	16
SAF209-26G 209-27G 209-28G 209G	1-5/8 1-11/16 1-3/4	45	137	105	22	16	38	54.7	16	11	M14	SA209-26G 209-27G 209-28G 209G	F209	2.00	-
SAF210-30G 210-31G 210G	1-7/8 1-15/16	50	143	111	22	16	40	54.7	18	11	M16	SA210-30G 210-31G 210G	F210	2.27	16
SAF211-32G 211-34G 211G 211-35G	2 2-1/8 2-3/16	55	162	130	25	18	43	61.4	18	12	M16	SA211-32G 211-34G 211G 211-35G	F211	3.07	19
SAF212-36G 212G 212-38G 212-39G	2-1/4 2-3/8 2-7/16	60	175	143	29	18	48	66.3	18	12	M16	SA212-36G 212G 212-38G 212-39G	F212	4.19	19



# SQUARE FLANGE UNITS

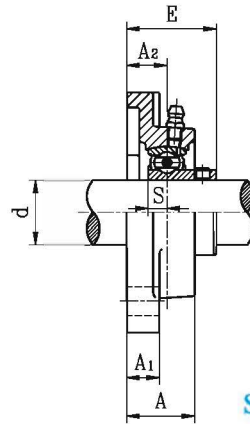
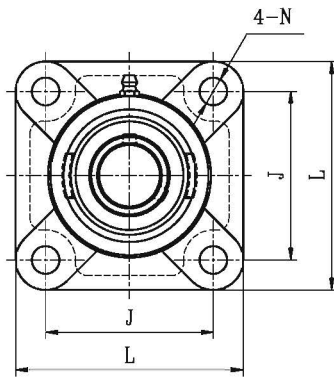

**SBF2G**  
Setscrew type

Unit No.	Shaft Dia.		Dimensions(mm).								Bolt Size	Bearing No.	Housing No.	Mass (kg)	Available
	d (in.)	d (mm)	L	J	A <sub>2</sub>	A <sub>1</sub>	A	E	N	S					
SBF201G 201-8G 202G 202-10G 203G 203-11G	1/2	12	76	54	15	11	24.5	31	11.5	6	M10	SB201G 201-8G 202G 202-10G 203G 203-11G	F203	0.38 0.37 0.36	--
	5/8	15													
	11/16	17													
SBF204-12G 204G	3/4	20	86	64	15	11	25.5	33	11.5	7	M10	SB204-12G 204G	F204	0.56	12
SBF205-14G 205-15G 205G 205-16G	7/8	25	95	70	16	13	27	35.5	11.5	7.5	M10	SB205-14G 205-15G 205G 205-16G	F205	0.75	12
	15/16														
	1														
SBF206-18G 206G 206-19G 206-20G	1-1/8	30	108	83	18	13	31	40	11.5	8	M10	SB206-18G 206G 206-19G 206-20G	F206	1.06	12
	1-3/16														
	1-1/4														
SBF207-20G 207-21G 207-22G 207G 207-23G	1-1/4	35	117	92	19	15	34	42.5	14	8.5	M12	SB207-20G 207-21G 207-22G 207G 207-23G	F207	1.45	--
	1-5/16														
	1-3/8														
	1-7/16														
SBF208-24G 208-25G 208G	1-1/2	40	130	102	21	15	36	46	14	9	M12	SB208-24G 208-25G 208G	F208	1.66	16
	1-9/16														
SBF209-26G 209-27G 209-28G 209G	1-5/8	45	137	105	22	16	38	53	16	10.2	M14	SB209-26G 209-27G 209-28G 209G	F209	1.90	-
	1-11/16														
	1-3/4														
SBF210-30G 210-31G 210G	1-7/8	50	143	111	22	16	40	54.6	18	10.9	M16	SB210-30G 210-31G 210G	F210	2.20	16
	1-15/16														
SBF211-32G 211-34G 211G 211-35G	2	55	162	130	25	18	43	58.5	18	11.8	M16	SB211-32G 211-34G 211G 211-35G	F211	2.95	19
	2-1/8														
	2-3/16														
SBF212-36G 212G 212-38G 212-39G	2-1/4	60	175	143	29	18	48	67.8	18	14.9	M16	SB212-36G 212G 212-38G 212-39G	F212	4.10	19
	2-3/8														
	2-7/16														



# SQUARE FLANGE UNITS

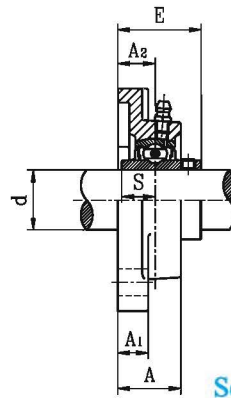
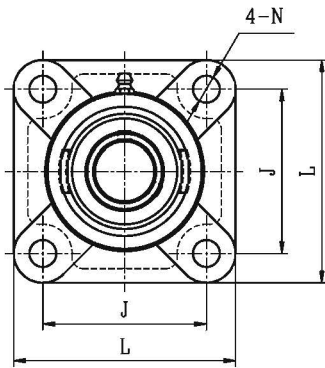

UCFX  
Setscrew type

Unit No.	Shaft Dia.		Dimensions(mm).								Bolt Size	Bearing No.	Housing No.	Mass (kg)
	d (in.)	d (mm)	L	J	A <sub>2</sub>	A <sub>1</sub>	A	E	N	S				
UCFX05-14 X05-15 X05 X05-16	7/8 15/16 1	25	108	82.5	18	13	30	40.2	11.5	15.9	M10	UCX05-14 X05-15 X05 X05-16	FX05	1.13
UCFX06-18 X06 X06-19 X06-20	1-1/8 1-3/16 1-1/4	30	117	92	19	14	34	44.4	13	17.5	M12	UCX06-18 X06 X06-19 X06-20	FX06	1.48
UCFX07-22 X07 X07-23	1-3/8 1-7/16	35	130	101.5	21	14	38	51.2	13	19	M12	UCX07-22 X07 X07-23	FX07	1.99
UCFX08-24 X08-25 X08	1-1/2 1-9/16	40	137	105	22	14	40	52.2	15	19	M14	UCX08-24 X08-25 X08	FX08	2.18
UCFX09-26 X09-27 X09-28 X09	1-5/8 1-11/16 1-3/4	45	143	111	23	14	40	55.6	15	19	M14	UCX09-26 X09-27 X09-28 X09	FX09	2.22
UCFX10-30 X10-31 X10 X10-32	1-7/8 1-15/16 2	50	162	130	26	20	44	59.4	17	22.2	M16	UCX10-30 X10-31 X10 X10-32	FX10	3.52
UCFX11-34 X11 X11-35 X11-36	2-1/8 2-3/16 2-1/4	55	175	143	29	20	49	68.7	17	25.4	M16	UCX11-34 X11 X11-35 X11-36	FX11	4.04
UCFX12 X12-38 X12-39	2-3/8 2-7/16	60	187	149	34	21	57	73.7	17	25.4	M16	UCX12 X12-38 X12-39	FX12	5.61
UCFX13-40 X13	2-1/2	65	187	149	34	21	59	78.4	17	30.2	M16	UCX13-40 X13	FX13	5.76
UCFX14-44 X14	2-3/4	70	197	152	37	24	60	81.5	20	33.3	M18	UCX14-44 X14	FX14	6.61
UCFX15 X15-48	3	75	197	152	40	24	68	89.3	20	33.3	M18	UCX15 X15-48	FX15	7.51
UCFX16		80	214	171	40	24	70	91.6	20	34.1	M18	UCX16	FX16	9.85
UCFX17-52 X17	3-1/4	85	214	171	40	24	70	96.3	20	39.7	M18	UCX17-52 X17	FX17	10.7
UCFX18-56 X18	3-1/2	90	214	171	45	24	76	106.1	23	42.9	M20	UCX18-56 X18	FX18	11.7
UCFX20 X20-64	4	100	268	211	59	31	97	127.3	31	49.2	M27	UCX20 X20-64	FX20	20.8



# SQUARE FLANGE UNITS

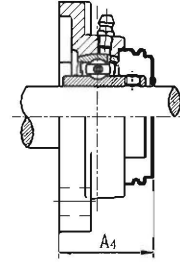
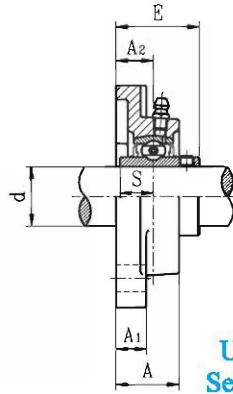
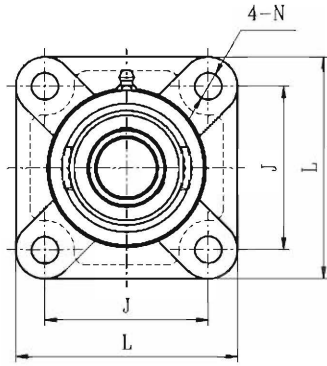

UCFU2  
Setscrew type

S-UCFU200E1  
SM-UCFU200E1  
With end cover

Unit No.	Shaft Dia.		Dimensions(mm).										Bolt Size	Bearing No.	Housing No.	Mass (kg)
	d (in.)	d (mm)	L	J	A2	A1	A	E	N	S	A4					
UCFU201S 201-8S 202S 202-10S 203S 203-11S	1/2 5/8 11/16	12 15 17	76	54	15	11	24.5	30.9	11.5	11.5	--	M10	UC201S 201-8S 202S 202-10S 203S 203-11S	FU203	0.39 0.38 0.37	
UCFU201 201-8 202 202-10 203 203-11 204-12 204	1/2 5/8 11/16 3/4	12 15 17 20	86	63.5	19	15	29.5	37.3	11.5	12.7	41.5	M10	UC201 201-8 202 202-10 203 203-11 204-12 204	FU204	0.67 0.65 0.64 0.62	
UCFU205-14 205-15 205 205-16	7/8 15/16 1	25	93	70	19	15	30	38.7	11.5	14.3	43	M10	UC205-14 205-15 205 205-16	FU205	0.78	
UCFU206-18 206 206-19 206-20	1-1/8 1-3/16 1-1/4	30	106	82.5	20	16	32.5	42.2	11.5	15.9	46	M10	UC206-18 206 206-19 206-20	FU206	1.01	
UCFU207-20 207-21 207-22 207 207-23	1-1/4 1-5/16 1-3/8 1-7/16	35	116	92	21	17	35	46.2	14	17.5	50.5	M12	UC207-20 207-21 207-22 207 207-23	FU207	1.37	
UCFU208-24 208-25 208	1-1/2 1-9/16	40	129	101.5	24	17	39	54.2	14	19	58	M12	UC208-24 208-25 208	FU208	1.81	
UCFU209-26 209-27 209-28 209	1-5/8 1-1/16 1-3/4	45	135	105	24	18	40	54.2	16	19	59	M14	UC209-26 209-27 209-28 209	FU209	2.09	
UCFU210-30 210-31 210	1-7/8 1-15/16	50	143	111	28	20	45	60.6	18	19	66	M16	UC210-30 210-31 210	FU210	2.43	
UCFU211-32 211-34 211 211-35	2 2-1/8 2-3/16	55	162	130	31	21	49	64.4	18	22.2	70	M16	UC211-32 211-34 211 211-35	FU211	3.46	
UCFU212-36 212 212-38 212-39	2-1/4 2-3/8 2-7/16	60	175	143	34	22	53.5	73.7	18	25.4	79.5	M16	UC212-36 212 212-38 212-39	FU212	4.09	
UCFU213-40 213	2-1/2	65	184	149	38	22	58	77.7	18	25.4	87	M16	UC213-40 213	FU213	4.88	
UCFU214-44 214	2-3/4	70	188	152	38	23	60	82.4	18	30.2	--	M16	UC214-44 214	FU214	5.49	
UCFU215-47 215 215-48	2-15/16 3	75	200	159	41	24	62	85.5	18	33.3	--	M16	UC215-47 215 215-48	FU215	6.15	
UCFU216		80	207	165	42	25	63	91.3	22	33.3	--	M20	UC216	FU216	7.03	

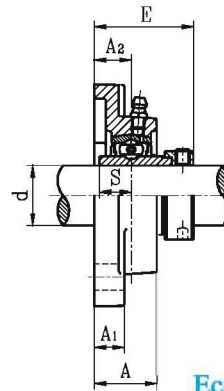
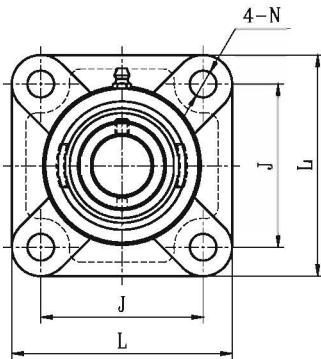

**NAFU2**  
Eccentric locking collar type

Unit No.	Shaft Dia.		Dimensions(mm).								Bolt Size	Bearing No.	Housing No.	Mass (kg)
	d (in.)	d (mm)	L	J	A <sub>2</sub>	A <sub>1</sub>	A	E	N	S				
NAFU201S 201-8S 202S 202-10S 203S 203-11S	1/2 5/8 11/16	12 15 17	76	54	15	11	24.5	38.4	11.5	13.9	M10	NA201S 201-8S 202S 202-10S 203S 203-11S	FU203	0.50 0.49 0.47
NAFU201 201-8 202 202-10 203 203-11 204-12 204	1/2 5/8 11/16 3/4	12 15 17 20	86	63.5	19	15	29.5	45.5	11.5	17	M10	NA201 201-8 202 202-10 203 203-11 204-12 204	FU204	0.74 0.71 0.70 0.67
NAFU205-14 205-15 205 205-16	7/8 15/16 1	25	93	70	19	15	30	45.9	11.5	17.4	M10	NA205-14 205-15 205 205-16	FU205	0.83
NAFU206-18 206 206-19 206-20	1-1/8 1-3/16 1-1/4	30	106	82.5	20	16	32.5	50.1	11.5	18.2	M10	NA206-18 206 206-19 206-20	FU206	1.08
NAFU207-20 207-21 207-22 207 207-23	1-1/4 1-5/16 1-3/8 1-7/16	35	116	92	21	17	35	53.3	14	18.8	M12	NA207-20 207-21 207-22 207 207-23	FU207	1.44
NAFU208-24 208-25 208	1-1/2 1-9/16	40	129	101.5	24	17	39	58.9	14	21.4	M12	NA208-24 208-25 208	FU208	1.92
NAFU209-26 209-27 209-28 209	1-5/8 1-11/16 1-3/4	45	135	105	24	18	40	58.9	16	21.4	M14	NA209-26 209-27 209-28 209	FU209	2.21
NAFU210-30 210-31 210	1-7/8 1-15/16	50	143	111	28	20	45	66.1	18	24.6	M16	NA210-30 210-31 210	FU210	2.60
NAFU211-32 211-34 211 211-35	2 2-1/8 2-3/16	55	162	130	31	21	49	74.6	18	27.7	M16	NA211-32 211-34 211 211-35	FU211	3.71
NAFU212-36 212 212-38 212-39	2-1/4 2-3/8 2-7/16	60	175	143	34	22	53.5	80.8	18	30.9	M16	NA212-36 212 212-38 212-39	FU212	4.37
NAFU213-40 213	2-1/2	65	184	149	38	22	58	89.6	18	34.1	M16	NA213-40 213	FU213	5.27
NAFU214-44 214	2-3/4	70	188	152	38	23	60	89.6	18	34.1	M16	NA214-44 214	FU214	5.53
NAFU215 215-48	3	75	200	159	41	24	62	95.8	18	37.3	M16	NA215 215-48	FU215	6.61
NAFU216		80	207	165	42	25	63	99.9	22	37.3	M20	NA216	FU216	7.65



# SQUARE FLANGE UNITS

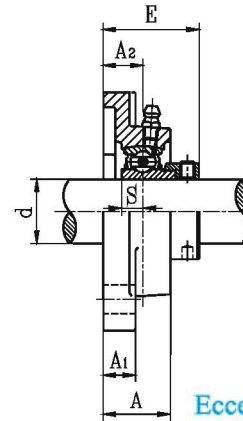
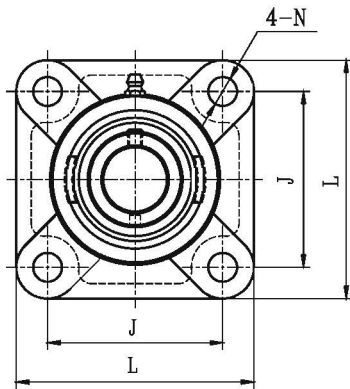

**SAFU2G**  
Eccentric locking collar type

Unit No.	Shaft Dia.		Dimensions(mm).								Bolt Size	Bearing No.	Housing No.	Mass (kg)
	d		L	J	A <sub>2</sub>	A <sub>1</sub>	A	E	N	S				
	(in.)	(mm)												
SAFU201G		12												0.40
201-8G	1/2	15	76	54	15	11	24.5	37.1	11.5	6.5	M10	SA201G 201-8G 202G 202-10G 203G 203-11G	FU203	0.39
202G		17												0.37
202-10G	5/8													
203G														
203-11G	11/16													
SAFU204-12G	3/4	20	86	63.5	19	15	29.5	42.4	11.5	7.5	M10	SA204-12G 204G	FU204	0.62
204G														
SAFU205-14G	7/8		93	70	19	15	30	42.4	11.5	7.5	M10	SA205-14G 205-15G 205G 205-16G	FU205	0.77
205-15G	15/16	25												
205G														
205-16G	1													
SAFU206-18G	1-1/8		106	82.5	20	16	32.5	46.7	11.5	9	M10	SA206-18G 206G 206-19G 206-20G	FU206	1.00
206G		30												
206-19G	1-3/16													
206-20G	1-1/4													
SAFU207-20G	1-1/4		116	92	21	17	35	50.4	14	9.5	M12	SA207-20G 207-21G 207-22G 207G 207-23G	FU207	1.34
207-21G	1-5/16													
207-22G	1-3/8	35												
207G														
207-23G	1-7/16													
SAFU208-24G	1-1/2		129	10.1.5	24	17	39	56.7	14	11	M12	SA208-24G 208-25G 208G	FU208	1.79
208-25G	1-9/16	40												
208G														
SAFU209-26G	1-5/8		135	105	24	18	40	56.7	16	11	M14	SA209-26G 209-27G 209-28G 209G	FU209	2.07
209-27G	1-11/16	45												
209-28G	1-3/4													
209G														
SAFU210-30G	1-7/8		143	111	28	20	45	60.7	18	11	M16	SA210-30G 210-31G 210G	FU210	2.38
210-31G	1-15/16	50												
210G														
SAFU211-32G	2		162	130	31	21	49	67.4	18	12	M16	SA211-32G 211-34G 211G 211-35G	FU211	3.46
211-34G	2-1/8	55												
211G														
211-35G	2-3/16													
SAFU212-36G	2-1/4		175	143	34	22	53.5	71.3	18	12	M16	SA212-36G 212G 212-38G 212-39G	FU212	3.94
212G		60												
212-38G	2-3/8													
212-39G	2-7/16													



# SQUARE FLANGE UNITS

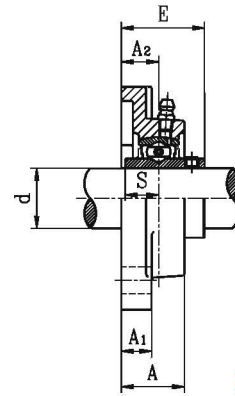
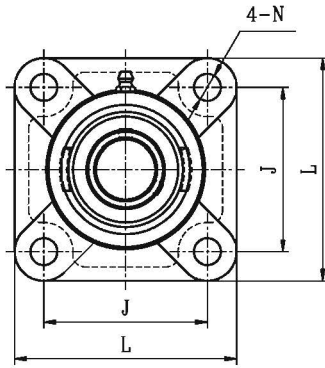

UCF3  
Setscrew type

Unit No.	Shaft Dia.		Dimensions(mm).								Bolt Size	Bearing No.	Housing No.	Mass (kg)
	d		L	J	A <sub>2</sub>	A <sub>1</sub>	A	E	N	S				
	(in.)	(mm)												
UCF305-14 305-15 305 305-16	7/8 15/16 1	25	108	80	16	13	29	39	16	15	M14	UC305-14 305-15 305 305-16	F305	1.04
UCF306-18 306 306-19	1-1/8 1-3/16	30	125	95	18	15	32	44	16	17	M14	UC306-18 306 306-19	F306	1.58
UCF307-20 307-21 307-22 307	1-1/4 1-5/16 1-3/8	35	135	100	20	16	36	49	19	19	M16	UC307-20 307-21 307-22 307	F307	1.96
UCF308-24 308-25 308	1-1/2 1-9/16	40	150	112	23	17	40	56	19	19	M16	UC308-24 308-25 308	F308	2.72
UCF309-26 309-27 309-28 309	1-5/8 1-11/16 1-3/4	45	160	125	25	18	44	60	19	22	M16	UC309-26 309-27 309-28 309	F309	3.26
UCF310-30 310-31 310	1-7/8 1-15/16	50	175	132	28	20	48	67	23	22	M20	UC310-30 310-31 310	F310	4.31
UCF311-32 311-34 311 311-35	2 2-1/8 2-3/16	55	185	140	30	20	52	71	23	25	M20	UC311-32 311-34 311 311-35	F311	5.28
UCF312-36 312 312-38 312-39	2-1/4 2-3/8 2-7/16	60	193	150	33	22	56	78	23	26	M20	UC312-36 312 312-38 312-39	F312	6.26
UCF313-40 313	2-1/2	65	208	166	33	22	58	78	23	30	M20	UC313-40 313	F313	7.65
UCF314-44 314	2-3/4	70	226	178	36	25	61	83	25	31	M22	UC314-44 314	F314	9.23
UCF315 315-48	3	75	236	184	39	25	66	89	25	32	M22	UC315 315-48	F315	10.5
UCF316		80	250	196	38	27	68	90	31	34	M27	UC316	F316	12.4
UCF317-52 317	3-1/4	85	260	204	44	27	74	100	31	40	M27	UC317-52 317	F317	15.3
UCF318-56 318	3-1/2	90	280	216	44	30	76	100	35	40	M30	UC318-56 318	F318	17.6
UCF319 319-60	3-3/4	95	290	228	59	30	94	121	35	41	M30	UC319 319-60	F319	21.6
UCF320 320-64	4	100	310	242	59	32	94	125	38	42	M33	UC320 320-64	F320	25.6
UCF322		110	340	266	60	35	96	131	41	46	M36	UC322	F322	35.2
UCF324		120	370	290	65	40	110	140	41	51	M36	UC324	F324	49.3
UCF326		130	410	320	65	45	115	146	41	54	M36	UC326	F326	63.4
UCF328		140	450	350	75	55	125	161	41	59	M36	UC328	F328	77.5



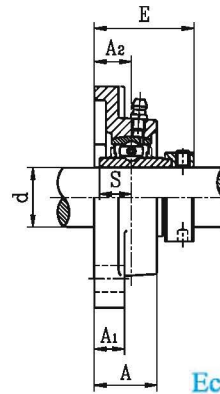
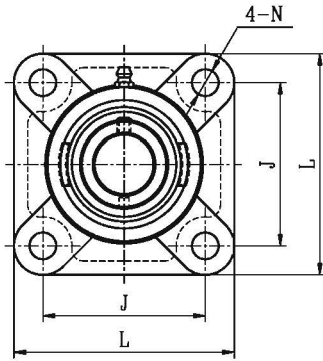

NAF3  
Eccentric locking collar type

Unit No.	Shaft Dia.		Dimensions(mm).								Bolt Size	Bearing No.	Housing No.	Mass (kg)
	d		L	J	A <sub>2</sub>	A <sub>1</sub>	A	E	N	S				
	(in.)	(mm)												
NAF305-14 305-15 305 305-16	7/8 15/16 1	25	108	80	16	13	29	46.1	16	16.7	M14	NA305-14 305-15 305 305-16	F305	1.11
NAF306-18 306 306-19	1-1/8 1-3/16	30	125	95	18	15	32	50.5	16	17.5	M14	NA306-18 306 306-19	F306	1.72
NAF307-20 307-21 307-22 307	1-1/4 1-5/16 1-3/8	35	135	100	20	16	36	53.3	19	18.3	M16	NA307-20 307-21 307-22 307	F307	2.06
NAF308-24 308-25 308	1-1/2 1-9/16	40	150	112	23	17	40	60.3	19	19.8	M16	NA308-24 308-25 308	F308	2.86
NAF309-26 309-27 309-28 309	1-5/8 1-11/16 1-3/4	45	160	125	25	18	44	63.9	19	19.8	M16	NA309-26 309-27 309-28 309	F309	3.39
NAF310-30 310-31 310	1-7/8 1-15/16	50	175	132	28	20	48	70	23	24.6	M20	NA310-30 310-31 310	F310	4.53
NAF311-32 311-34 311 311-35	2 2-1/8 2-3/16	55	185	140	30	20	52	75.2	23	27.8	M20	NA311-32 311-34 311 311-35	F311	5.53
NAF312-36 312 312-38 312-39	2-1/4 2-3/8 2-7/16	60	193	150	33	22	56	81.45	23	30.95	M20	NA312-36 312 312-38 312-39	F312	6.57
NAF313-40 313	2-1/2	65	208	166	33	22	58	86.2	23	32.5	M20	NA313-40 313	F313	8.17
NAF314-44 314	2-3/4	70	226	178	36	25	61	93.95	25	34.15	M22	NA314-44 314	F314	9.89
NAF315 315-48	3	75	236	184	39	25	66	101.7	25	37.3	M22	NA315 315-48	F315	11.5
NAF316		80	250	196	38	27	68	103.9	31	40.5	M27	NA316	F316	13.5
NAF317-52 317	3-1/4	85	260	204	44	27	74	111.5	31	42	M27	NA317-52 317	F317	16.3
NAF318-56 318	3-1/2	90	280	216	44	30	76	116.3	35	43.6	M30	NA318-56 318	F318	19.0
NAF319 319-60	3-3/4	95	290	228	59	30	94	134.5	35	46.8	M30	NA319 319-60	F319	23.0
NAF320 320-64	4	100	310	242	59	32	94	137.6	38	50	M33	NA320 320-64	F320	27.9

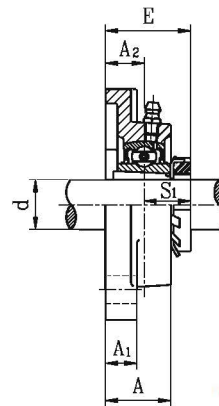
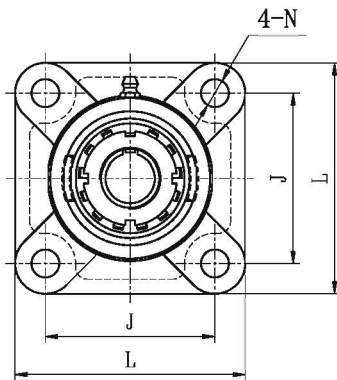

**UKF3+H**  
Tapered bore, adapter type

Unit No.	Shaft Dia.		Dimensions(mm).								Bolt Size	Bearing No.	Housing No.	Adapter No.	Mass (kg)
	d (in.)	(mm)	L	J	A <sub>2</sub>	A <sub>1</sub>	A	E	N	S <sub>1</sub>					
UKF305+HE2305 305+H2305	3/4	20	108	80	16	13	29	37.5	16	21.5	M14	UK305	F305	HE2305 H2305	1.09
UKF306+HS2306 306+HA2306 306+H2306 306+HE2306	7/8 15/16 1	25	125	95	18	15	32	41	16	23	M14	UK306	F306	HS2306 HA2306 H2306 HE2306	1.65
UKF307+HS2307 307+H2307 307+HA2307	1-1/8 1-3/16	30	135	100	20	16	36	45.5	19	25.5	M16	UK307	F307	HS2307 H2307 HA2307	2.00
UKF308+HE2308 308+HS2308 308+H2308	1-1/4 1-3/8	35	150	112	23	17	40	50.5	19	27.5	M16	UK308	F308	HE2308 HS2308 H2308	2.77
UKF309+HA2309 309+HE2309 309+H2309	1-7/16 1-1/2	40	160	125	25	18	44	55	19	30	M16	UK309	F309	HA2309 HE2309 H2309	3.40
UKF310+HS2310 310+HA2310 310+HE2310 310+H2310	1-5/8 1-11/16 1-3/4	45	175	132	28	20	48	60	23	32	M20	UK310	F310	HS2310 HA2310 HE2310 H2310	4.35
UKF311+HS2311 311+HA2311 311+H2311 311+HE2311	1-7/8 1-15/16 2	50	185	140	30	20	52	63.5	23	33.5	M20	UK311	F311	HS2311 HA2311 H2311 HE2311	5.30
UKF312+HS2312 312+H2312	2-1/8	55	193	150	33	22	56	69.5	23	36.5	M20	UK312	F312	HS2312 H2312	6.26
UKF313+HA2313 313+HE2313 313+H2313 313+HS2313	2-3/16 2-1/4 2-3/8	60	208	166	33	22	58	71.5	23	38.5	M20	UK313	F313	HA2313 HE2313 H2313 HS2313	7.61
UKF315+HA2315 315+HE2315 315+H2315	2-7/16 2-1/2	65	236	184	39	25	66	81.5	25	42.5	M22	UK315	F315	HA2315 HE2315 H2315	10.8
UKF316+HA2316 316+HE2316 316+H2316	2-11/16 2-3/4	70	250	196	38	27	68	82.5	31	44.5	M27	UK316	F316	HA2316 HE2316 H2316	12.7
UKF317+HA2317 317+H2317 317+HE2317	2-15/16 3	75	260	204	44	27	74	92	31	48	M27	UK317	F317	HA2317 H2317 HE2317	15.3
UKF318+H2318		80	280	216	44	30	76	92	35	48	M30	UK318	F318	H2318	17.7
UKF319+HE2319 319+H2319	3-1/4	85	290	228	59	30	94	111	35	52	M30	UK319	F319	HE2319 H2319	21.4
UKF320+HE2320 320+H2320	3-1/2	90	310	242	59	32	94	113	38	54	M33	UK320	F320	HE2320 H2320	25.6
UKF322+H2322		100	340	266	60	35	96	121	41	61	M36	UK322	F322	H2322	35.2
UKF324+H2324		110	370	290	65	40	110	130.5	41	65.5	M36	UK324	F324	H2324	48.9
UKF326+H2326		115	410	320	65	45	115	133	41	68	M36	UK326	F326	H2326	63.2
UKF328+H2328		125	450	350	75	55	125	148	41	73	M36	UK328	F328	H2328	77.3



# SQUARE FLANGE CARTRIDGE UNITS

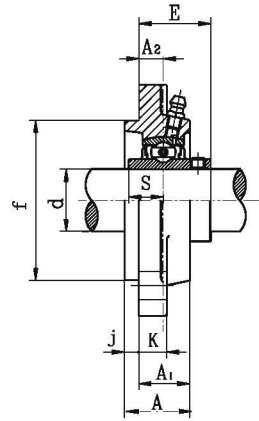
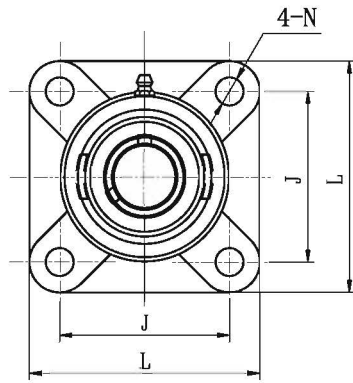

UCFS3  
Setscrew type

Unit No.	Shaft Dia.		Dimensions(mm).											Bolt Size	Bearing No.	Housing No.	Mass (kg)
	d		L	J	A <sub>2</sub>	A <sub>1</sub>	A	j	K	N	f	S	E				
	(in.)	(mm)															
UCFS305-14 305-15 305 305-16	7/8 15/16 1	25	110	80	9	22	29	7	13	16	80	15	32	M14	UC305-14 305-15 305 305-16	FS305	1.19
UCFS306-18 306 306-19	1-1/8 1-3/16	30	125	95	10	24	32	8	15	16	90	17	36	M14	UC306-18 306 306-19	FS306	1.77
UCFS307-20 307-21 307-22 307	1-1/4 1-5/16 1-3/8 307	35	135	100	11	27	36	9	16	19	100	19	40	M16	UC307-20 307-21 307-22 307	FS307	2.19
UCFS308-24 308-25 308	1-1/2 1-9/16	40	150	112	13	30	40	10	17	19	115	19	46	M16	UC308-24 308-25 308	FS308	3.10
UCFS309-26 309-27 309-28 309	1-5/8 1-11/16 1-3/4 309	45	160	125	14	33	44	11	18	19	125	22	49	M16	UC309-26 309-27 309-28 309	FS309	3.80
UCFS310-30 310-31 310	1-7/8 1-15/16	50	175	132	16	36	48	12	19	23	140	22	55	M20	UC310-30 310-31 310	FS310	4.95
UCFS311-32 311-34 311 311-35	2 2-1/8 2-3/16	55	185	140	17	39	52	13	20	23	150	25	58	M20	UC311-32 311-34 311 311-35	FS311	5.86
UCFS312-36 312 312-38 312-39	2-1/4 2-3/8 2-7/16	60	195	150	19	42	56	14	22	23	160	26	64	M20	UC312-36 312 312-38 312-39	FS312	7.52
UCFS313-40 313	2-1/2	65	208	166	15	40	58	18	22	23	175	30	60	M20	UC313-40 313	FS313	8.68
UCFS314-44 314	2-3/4	70	226	178	18	43	61	18	25	25	185	31	65	M22	UC314-44 314	FS314	10.7
UCFS315 315-48	3	75	236	184	21	48	66	18	25	25	200	32	71	M22	UC315 315-48	FS315	12.5
UCFS316		80	250	196	18	48	68	20	27	31	210	34	70	M27	UC316	FS316	14.4
UCFS317-52 317	3-1/4	85	260	204	24	54	74	20	27	31	220	40	80	M27	UC317-52 317	FS317	17.1
UCFS318-56 318	3-1/2	90	280	216	24	56	76	20	30	35	240	40	80	M30	UC318-56 318	FS318	20.8
UCFS319 319-60	3-3/4	95	290	228	39	74	94	20	30	35	250	41	101	M30	UC319 319-60	FS319	24.8
UCFS320 320-64	4	100	310	242	39	74	94	20	32	38	260	42	105	M33	UC320 320-64	FS320	29.3
UCFS322		110	340	266	35	71	96	25	35	41	300	46	106	M36	UC322	FS322	39.0
UCFS324		120	370	290	35	80	110	30	40	41	330	51	110	M36	UC324	FS324	52.6
UCFS326		130	410	320	35	85	115	30	45	41	360	54	116	M36	UC326	FS326	69.7
UCFS328		140	450	350	45	95	125	30	55	41	400	59	131	M36	UC328	FS328	93.1



# SQUARE FLANGE CARTRIDGE UNITS

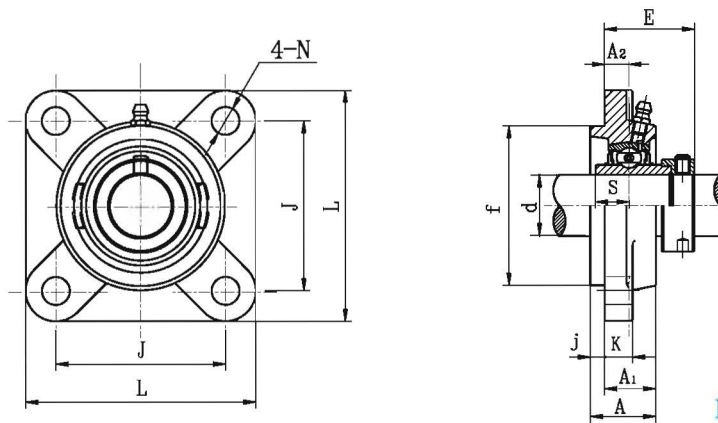

**NAFS3**  
Eccentric locking collar type

Unit No.	Shaft Dia.		Dimensions(mm).											Bolt Size	Bearing No.	Housing No.	Mass (kg)
	d		L	J	A <sub>2</sub>	A <sub>1</sub>	A	j	K	N	f	S	E				
	(in.)	(mm)															
NAFS305-14 305-15 305 305-16	7/8 15/16 1	25	110	80	9	22	29	7	13	16	80	16.7	39.1	M14	NA305-14 305-15 305 305-16	FS305	1.26
NAFS306-18 306 306-19	1-1/8 1-3/16	30	125	95	10	24	32	8	15	16	90	17.5	42.5	M14	NA306-18 306 306-19	FS306	1.91
NAFS307-20 307-21 307-22 307	1-1/4 1-5/16 1-3/8	35	135	100	11	27	36	9	16	19	100	18.3	44.3	M16	NA307-20 307-21 307-22 307	FS307	2.29
NAFS308-24 308-25 308	1-1/2 1-9/16	40	150	112	13	30	40	10	17	19	115	19.8	50.3	M16	NA308-24 308-25 308	FS308	3.24
NAFS309-26 309-27 309-28 309	1-5/8 1-11/16 1-3/4	45	160	125	14	33	44	11	18	19	125	19.8	52.9	M16	NA309-26 309-27 309-28 309	FS309	3.93
NAFS310-30 310-31 310	1-7/8 1-15/16	50	175	132	16	36	48	12	19	23	140	24.6	58	M20	NA310-30 310-31 310	FS310	5.17
NAFS311-32 311-34 311 311-35	2 2-1/8 2-3/16	55	185	140	17	39	52	13	20	23	150	27.8	62.2	M20	NA311-32 311-34 311 311-35	FS311	6.11
NAFS312-36 312 312-38 312-39	2-1/4 2-3/8 2-7/16	60	195	150	19	42	56	14	22	23	160	30.95	67.5	M20	NA312-36 312 312-38 312-39	FS312	7.83
NAFS313-40 313	2-1/2	65	208	166	15	40	58	18	22	23	175	32.5	68.2	M20	NA313-40 313	FS313	9.20
NAFS314-44 314	2-3/4	70	226	178	18	43	61	18	25	25	185	34.15	76	M22	NA314-44 314	FS314	11.4
NAFS315 315-48	3	75	236	184	21	48	66	18	25	25	200	37.3	83.7	M22	NA315 315-48	FS315	13.4
NAFS316		80	250	196	18	48	68	20	27	31	210	40.5	83.9	M27	NA316	FS316	15.5
NAFS317-52 317	3-1/4	85	260	204	24	54	74	20	27	31	220	42	91.5	M27	NA317-52 317	FS317	18.1
NAFS318-56 318	3-1/2	90	280	216	24	56	76	20	30	35	240	43.6	96.3	M30	NA318-56 318	FS318	22.2
NAFS319 319-60	3-3/4	95	290	228	39	74	94	20	30	35	250	46.8	114.5	M30	NA319 319-60	FS319	26.2
NAFS320 320-64	4	100	310	242	39	74	94	20	32	38	260	50	117.6	M33	NA320 320-64	FS320	31.7



# SQUARE FLANGE CARTRIDGE UNITS

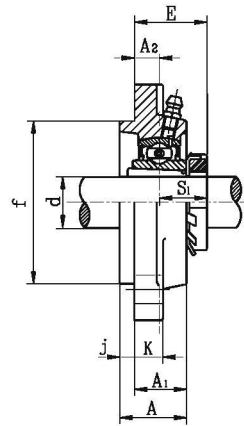
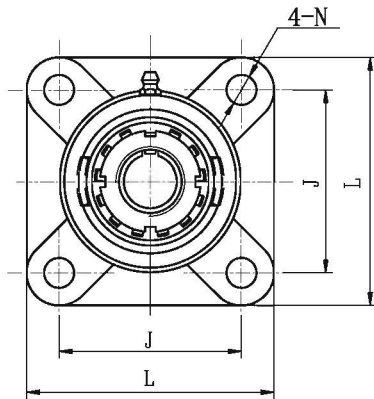

**UKFS3+H**  
Tapered bore, adapter type

Unit No.	Shaft Dia.		Dimensions(mm).											Bolt Size	Bearing No.	Housing No.	Adapter No.	Mass (kg)
	d		L	J	A <sub>2</sub>	A <sub>1</sub>	A	j	K	N	f	S <sub>1</sub>	E					
	(in.)	(mm)																
UKFS305+HE2305 305+H2305	3/4	20	110	80	9	22	29	7	13	16	80	21.5	30.5	M14	UK305	FS305	HE2305 H2305	1.24
UKFS306+HS2306 306+HA2306 306+H2306 306+HE2306	7/8 15/16 1	25	125	95	10	24	32	8	15	16	90	23	33	M14	UK306	FS306	HS2306 HA2306 H2306 HE2306	1.82
UKFS307+HS2307 307+H2307 307+HA2307	1-1/8 1-3/16	30	135	100	11	27	36	9	16	19	100	25.5	36.5	M16	UK307	FS307	HS2307 H2307 HA2307	2.23
UKFS308+HE2308 308+HS2308 308+H2308	1-1/4 1-3/8	35	150	112	13	30	40	10	17	19	115	27.5	40.5	M16	UK308	FS308	HE2308 HS2308 H2308	3.15
UKFS309+HA2309 309+HE2309 309+H2309	1-7/16 1-1/2	40	160	125	14	33	44	11	18	19	125	30	44	M16	UK309	FS309	HA2309 HE2309 H2309	3.94
UKFS310+HS2310 310+HA2310 310+HE2310 310+H2310	1-5/8 1-11/16 1-3/4	45	175	132	16	36	48	12	19	23	140	32	48	M20	UK310	FS310	HS2310 HA2310 HE2310 H2310	4.99
UKFS311+HS2311 311+HA2311 311+H2311 311+HE2311	1-7/8 1-15/16 2	50	185	140	17	39	52	13	20	23	150	33.5	50.5	M20	UK311	FS311	HS2311 HA2311 H2311 HE2311	5.88
UKFS312+HS2312 312+H2312	2-1/8	55	195	150	19	42	56	14	22	23	160	36.5	55.5	M20	UK312	FS312	HS2312 H2312	7.52
UKFS313+HA2313 313+HE2313 313+H2313 313+HS2313	2-3/16 2-1/4 2-3/8	60	208	166	15	40	58	18	22	23	175	38.5	53.5	M20	UK313	FS313	HA2313 HE2313 H2313 HS2313	8.64
UKFS315+HA2315 315+HE2315 315+H2315	2-7/16 2-1/2	65	236	184	21	48	66	18	25	25	200	42.5	63.5	M22	UK315	FS315	HA2315 HE2315 H2315	12.8
UKFS316+HA2316 316+HE2316 316+H2316	2-11/16 2-3/4	70	250	196	18	48	68	20	27	31	210	44.5	62.5	M27	UK316	FS316	HA2316 HE2316 H2316	14.7
UKFS317+HA2317 317+H2317 317+HE2317	2-15/16 3	75	260	204	24	54	74	20	27	31	220	48	72	M27	UK317	FS317	HA2317 H2317 HE2317	17.1
UKFS318+H2318		80	280	216	24	56	76	20	30	35	240	48	72	M30	UK318	FS318	H2318	20.9
UKFS319+HE2319 319+H2319	3-1/4	85	290	228	39	74	94	20	30	35	250	52	91	M30	UK319	FS319	HE2319 H2319	24.6
UKFS320+HE2320 320+H2320	3-1/2	90	310	242	39	74	94	20	32	38	260	54	93	M33	UK320	FS320	HE2320 H2320	29.4
UKFS322+H2322		100	340	266	35	71	96	25	35	41	300	61	96	M36	UK322	FS322	H2322	38.9
UKFS324+H2324		110	370	290	35	80	110	30	40	41	330	65.5	100.5	M36	UK324	FS324	H2324	52.2
UKFS326+H2326		115	410	320	35	85	115	30	45	41	360	68	103	M36	UK326	FS326	H2326	69.5
UKFS328+H2328		125	450	350	45	95	125	30	55	41	400	73	118	M36	UK328	FS328	H2328	92.9



# OVAL FLANGE UNITS

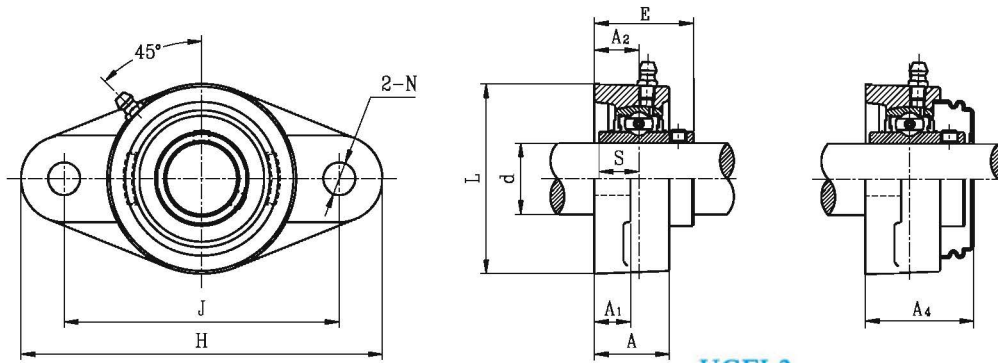

UCFL2  
Setscrew type

S-UCFL200E1  
SM-UCFL200E1  
With end cover

Unit No.	Shaft Dia.		Dimensions(mm).										Bolt Size	Bearing No.	Housing No.	Mass (kg)	Available
	d (in.)	d (mm)	H	J	L	A <sub>2</sub>	A <sub>1</sub>	A	E	N	S	A <sub>4</sub>					
UCFL201S 201-8S 202S 202-10S 203S 203-11S	1/2 5/8 11/16	12 15 17	99	76.5	57	15	11	24.5	30.9	11.5	11.5	--	M10	UC201S 201-8S 202S 202-10S 203S 203-11S	FL203	0.37 0.36 0.35	--
UCFL201 201-8 202 202-10 203 203-11 204-12 204	1/2 5/8 11/16 3/4	12 15 17 20	113	90	60	15	11	25.5	33.3	11.5	12.7	37.5	M10	UC201 201-8 202 202-10 203 203-11 204-12 204	FL204	0.47 0.45 0.44 0.42	12
UCFL205-14 205-15 205 205-16	7/8 15/16 1	25	130	99	68	16	13	27	35.7	11.5	14.3	40	M10	UC205-14 205-15 205 205-16	FL205	0.61	16
UCFL206-18 206 206-19 206-20	1-1/8 1-3/16 1-1/4	30	148	117	80	18	13	31	40.2	11.5	15.9	44	M10	UC206-18 206 206-19 206-20	FL206	0.90	16
UCFL207-20 207-21 207-22 207 207-23	1-1/4 1-5/16 1-3/8 1-7/16	35	161	130	90	19	14	34	44.4	14	17.5	48.5	M12	UC207-20 207-21 207-22 207 207-23	FL207	1.21	16
UCFL208-24 208-25 208	1-1/2 1-9/16	40	175	144	100	21	14	36	51.2	14	19	55	M12	UC208-24 208-25 208	FL208	1.55	16
UCFL209-26 209-27 209-28 209	1-5/8 1-11/16 1-3/4	45	188	148	108	22	16	38	52.2	18	19	57	M16	UC209-26 209-27 209-28 209	FL209	1.87	19
UCFL210-30 210-31 210 210-32	1-7/8 1-15/16 2	50	197	157	115	22	16	40	54.6	18	19	60	M16	UC210-30 210-31 210 210-32	FL210	2.16	19
UCFL211-32 211-34 211 211-35	2 2-1/8 2-3/16	55	224	184	130	25	18	43	58.4	18	22.2	64	M16	UC211-32 211-34 211 211-35	FL211	2.89	19
UCFL212-36 212 212-38 212-39	2-1/4 2-3/8 2-7/16	60	250	202	140	29	18	48	68.7	18	25.4	74.5	M16	UC212-36 212 212-38 212-39	FL212	3.75	23
UCFL213-40 213	2-1/2	65	258	210	155	30	20	50	69.7	23	25.4	79	M20	UC213-40 213	FL213	4.68	--
UCFL214-44 214	2-3/4	70	265	216	160	31	20	54	75.4	23	30.2	--	M20	UC214-44 214	FL214	5.26	--
UCFL215-47 215 215-48	2-15/16 3	75	275	225	164	34	22	55	78.5	23	33.3	--	M20	UC215-47 215 215-48	FL215	5.38	--
UCFL216		80	290	233	180	34	22	58	83.3	25	33.3	--	M22	UC216	FL216	6.76	--
UCFL217-52 217	3-1/4	85	305	248	190	36	22	63	87.6	25	34.1	--	M22	UC217-52 217	FL217	8.48	--
UCFL218-56 218	3-1/2	90	320	265	205	40	23	68	96.3	25	39.7	--	M22	UC218-56 218	FL218	10.3	--

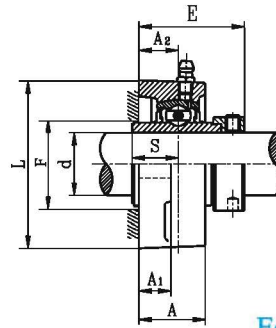
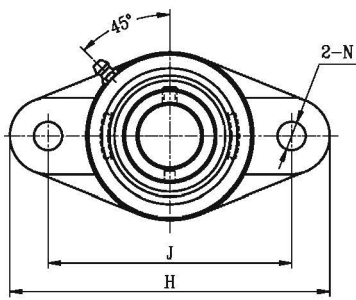

**NAFL2**  
Eccentric locking collar type

Unit No.	Shaft Dia.		Dimensions(mm).										Bolt Size	Bearing No.	Housing No.	Mass (kg)	Available
	d (in.)	d (mm)	H	J	L	A <sub>2</sub>	A <sub>1</sub>	A	E	N	S	F min.					
NAFL201S 201-8S 202S 202-10S 203S 203-11S	1/2 5/8 11/16	12 15 17	99	76.5	57	15	11	24.5	38.4	11.5	13.9	--	M10	NA201S 201-8S 202S 202-10S 203S 203-11S	FL203	0.48 0.47 0.45	--
NAFL201 201-8 202 202-10 203 203-11 204-12 204	1/2 5/8 11/16 3/4	12 15 17 20	113	90	60	15	11	25.5	41.5	11.5	17	31	M10	NA201 201-8 202 202-10 203 203-11 204-12 204	FL204	0.54 0.51 0.50 0.47	12
NAFL205-14 205-15 205 205-16	7/8 15/16 1	25	130	99	68	16	13	27	42.9	11.5	17.4	36	M10	NA205-14 205-15 205 205-16	FL205	0.66	16
NAFL206-18 206 206-19 206-20	1-1/8 1-3/16 1-1/4	30	148	117	80	18	13	31	48.1	11.5	18.2	42	M10	NA206-18 206 206-19 206-20	FL206	0.97	16
NAFL207-20 207-21 207-22 207 207-23	1-1/4 1-5/16 1-3/8 1-7/16	35	161	130	90	19	14	34	51.3	14	18.8	50	M12	NA207-20 207-21 207-22 207 207-23	FL207	1.28	16
NAFL208-24 208-25 208	1-1/2 1-9/16	40	175	144	100	21	14	36	55.9	14	21.4	55	M12	NA208-24 208-25 208	FL208	1.66	16
NAFL209-26 209-27 209-28 209	1-5/8 1-11/16 1-3/4	45	188	148	108	22	16	38	56.9	18	21.4	--	M16	NA209-26 209-27 209-28 209	FL209	1.99	19
NAFL210-30 210-31 210	1-7/8 1-15/16	50	197	157	115	22	16	40	60.1	18	24.6	64	M16	NA210-30 210-31 210	FL210	2.33	19
NAFL211-32 211-34 211 211-35	2 2-1/8 2-3/16	55	224	184	130	25	18	43	68.6	18	27.7	71	M16	NA211-32 211-34 211 211-35	FL211	3.14	19
NAFL212-36 212 212-38 212-39	2-1/4 2-3/8 2-7/16	60	250	202	140	29	18	48	75.8	18	30.9	77	M16	NA212-36 212 212-38 212-39	FL212	4.03	23
NAFL213-40 213	2-1/2	65	258	210	155	30	20	50	81.6	23	34.1	84	M20	NA213-40 213	FL213	5.07	--
NAFL214-44 214	2-3/4	70	265	216	160	31	20	54	82.6	23	34.1	89	M20	NA214-44 214	FL214	5.30	--
NAFL215 215-48	3	75	275	225	164	34	22	55	88.8	23	37.3	94	M20	NA215 215-48	FL215	5.84	--
NAFL216		80	290	233	180	34	22	58	91.9	25	37.3	101	M22	NA216	FL216	7.38	--
NAFL217-52 217	3-1/4	85	305	248	190	36	22	63	85.8	25	23.4	--	M22	NA217-52 217	FL217	8.69	--
NAFL218-56 218	3-1/2	90	320	265	205	40	23	68	88	25	24.5	--	M22	NA218-56 218	FL218	9.97	--

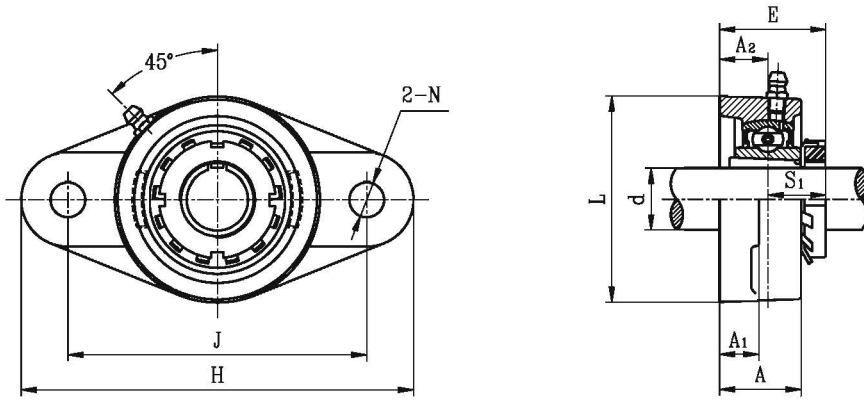

**UKFL2+H**  
Tapered bore, adapter type

Unit No.	Shaft Dia.		Dimensions(mm).									Bolt Size	Bearing No.	Housing No.	Adapter No.	Mass (kg)	Available
	d (in.)	d (mm)	H	J	L	A <sub>2</sub>	A <sub>1</sub>	A	E	N	S <sub>1</sub>						
UKFL205+HE2305 205+H2305	3/4	20	130	99	68	16	13	27	34.5	11.5	18.5	M10	UK205	FL205	HE2305 H2305	0.65	16
UKFL206+HS2306 206+HA2306 206+H2306 206+HE2306	7/8 15/16 1	25	148	117	80	18	13	31	38.5	11.5	20.5	M10	UK206	FL206	HS2306 HA2306 H2306 HE2306	0.97	16
UKFL207+HS2307 207+H2307 207+HA2307	1-1/8 1-3/16	30	161	130	90	19	14	34	41.5	14	22.5	M12	UK207	FL207	HS2307 H2307 HA2307	1.26	16
UKFL208+HE2308 208+HS2308 208+H2308	1-1/4 1-3/8	35	175	144	100	21	14	36	45.5	14	24.5	M12	UK208	FL208	HE2308 HS2308 H2308	1.61	16
UKFL209+HA2309 209+HE2309 209+H2309	1-7/16 1-1/2	40	188	148	108	22	16	38	48	18	26	M16	UK209	FL209	HA2309 HE2309 H2309	1.98	19
UKFL210+HS2310 210+HA2310 210+HE2310 210+H2310	1-5/8 1-11/16 1-3/4	45	197	157	115	22	16	40	49.5	18	27.5	M16	UK210	FL210	HS2310 HA2310 HE2310 H2310	2.34	19
UKFL211+HS2311 211+HA2311 211+H2311 211+HE2311	1-7/8 1-15/16 2	50	224	184	130	25	18	43	53.5	18	28.5	M16	UK211	FL211	HS2311 HA2311 H2311 HE2311	3.05	19
UKFL212+HS2312 212+H2312	2-1/8	55	250	202	140	29	18	48	60	18	31	M16	UK212	FL212	HS2312 H2312	3.85	23
UKFL213+HA2313 213+HE2313 213+H2313 213+HS2313	2-3/16 2-1/4 2-3/8	60	258	210	155	30	20	50	62	23	32	M20	UK213	FL213	HA2313 HE2313 H2313 HS2313	4.76	--
UKFL215+HA2315 215+HE2315 215+H2315	2-7/16 2-1/2	65	275	225	164	34	22	55	69.5	23	35.5	M20	UK215	FL215	HA2315 HE2315 H2315	5.75	--
UKFL216+HA2316 216+HE2316 216+H2316	2-11/16 2-3/4	70	290	233	180	34	22	58	73	25	39	M22	UK216	FL216	HA2316 HE2316 H2316	7.23	--
UKFL217+H2317	75	305	248	190	36	22	63	76	76	25	40	M22	UK217	FL217	H2317	8.87	--
UKFL218+H2318	80	320	265	205	40	23	68	82	82	25	42	M22	UK218	FL218	H2318	10.7	--



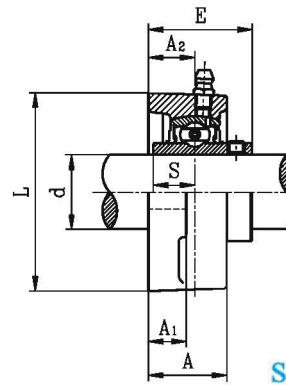
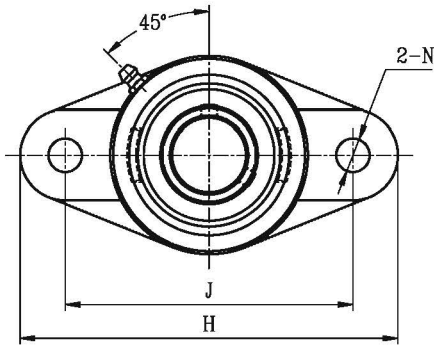

**UCFLX**  
Setscrew type

Unit No.	Shaft Dia.		Dimensions(mm).									Bolt Size	Bearing No.	Housing No.	Mass (kg)
	d		H	J	L	A <sub>2</sub>	A <sub>1</sub>	A	E	N	S				
	(in.)	(mm)													
UCFLX05-14 X05-15 X05 X05-16	7/8 15/16 1	25	141	117	83	18	13	30	40.2	12	15.9	M10	UCX05-14 X05-15 X05 X05-16	FLX05	0.97
UCFLX06-18 X06 X06-19 X06-20	1-1/8 1-3/16 1-1/4	30	156	130	95	19	14	34	44.4	16	17.5	M14	UCX06-18 X06 X06-19 X06-20	FLX06	1.31
UCFLX07-22 X07 X07-23	1-3/8 1-7/16	35	171	144	105	21	14	38	51.2	16	19	M14	UCX07-22 X07 X07-23	FLX07	1.76
UCFLX08-24 X08-25 X08	1-1/2 1-9/16	40	179	148	111	22	14	40	52.2	16	19	M14	UCX08-24 X08-25 X08	FLX08	2.03
UCFLX09-26 X09-27 X09-28 X09	1-5/8 1-11/16 1-3/4	45	189	157	116	23	14	40	55.6	16	19	M14	UCX09-26 X09-27 X09-28 X09	FLX09	2.17
UCFLX10-30 X10-31 X10 X10-32	1-7/8 1-15/16 2	50	216	184	133	26	20	44	59.4	19	22.2	M16	UCX10-30 X10-31 X10 X10-32	FLX10	3.25

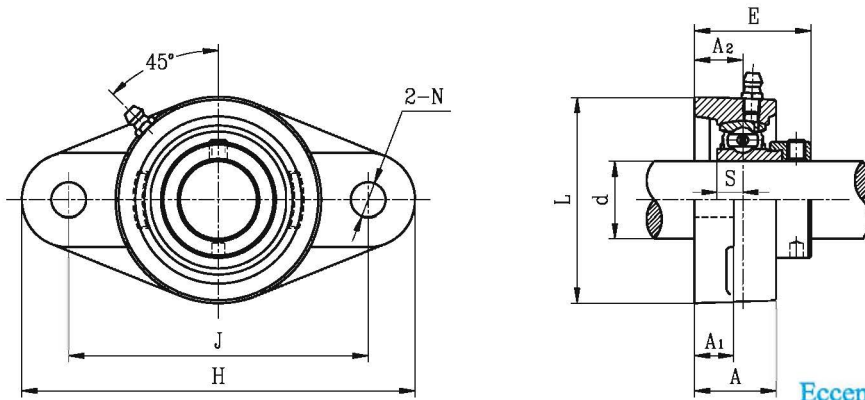

**SAFL2G**  
Eccentric locking collar type

Unit No.	Shaft Dia.		Dimensions(mm).									Bolt Size	Bearing No.	Housing No.	Mass (kg)	Available N
	d (in.)	d (mm)	H	J	L	A <sub>2</sub>	A <sub>1</sub>	A	E	N	S					
SAFL201G 201-8G 202G 202-10G 203G 203-11G	1/2 5/8 11/16	12 15 17	99	76.5	57	15	11	24.5	37.1	11.5	6.5	M10	SA201G 201-8G 202G 202-10G 203G 203-11G	FL203	0.38 0.37 0.35	--
SAFL204-12G 204G	3/4	20	113	90	60	15	11	25.5	38.4	11.5	7.5	M10	SA204-12G 204G	FL204	0.42	12
SAFL205-14G 205-15G 205G 205-16G	7/8 15/16 1	25	130	99	68	16	13	27	39.4	11.5	7.5	M10	SA205-14G 205-15G 205G 205-16G	FL205	0.60	16
SAFL206-18G 206G 206-19G 206-20G	1- 1/8 1- 3/16 1- 1/4	30	148	117	80	18	13	31	44.7	11.5	9	M10	SA206-18G 206G 206-19G 206-20G	FL206	0.89	16
SAFL207-20G 207-21G 207-22G 207G 207-23G	1- 1/4 1- 5/16 1- 3/8 1- 7/16	35	161	130	90	19	14	34	48.4	14	9.5	M12	SA207-20G 207-21G 207-22G 207G 207-23G	FL207	1.18	16
SAFL208-24G 208-25G 208G	1- 1/2 1- 9/16	40	175	144	100	21	14	36	53.7	14	11	M12	SA208-24G 208-25G 208G	FL208	1.53	16
SAFL209-26G 209-27G 209-28G 209G	1-5/8 1-11/16 1-3/4	45	188	148	108	22	16	38	54.7	18	11	M16	SA209-26G 209-27G 209-28G 209G	FL209	1.85	19
SAFL210-30G 210-31G 210G 210-32G	1-7/8 1-15/16 2	50	197	157	115	22	16	40	54.7	18	11	M16	SA210-30G 210-31G 210G 210-32G	FL210	2.11	19
SAFL211-32G 211-34G 211G 211-35G	2 2-1/8 2-3/16	55	224	184	130	25	18	43	61.4	18	12	M16	SA211-32G 211-34G 211G 211-35G	FL211	2.89	19
SAFL212-36G 212G 212-38G 212-39G	2-1/4 2-3/8 2-7/16	60	250	202	140	29	18	48	66.3	18	12	M16	SA212-36G 212G 212-38G 212-39G	FL212	3.60	23

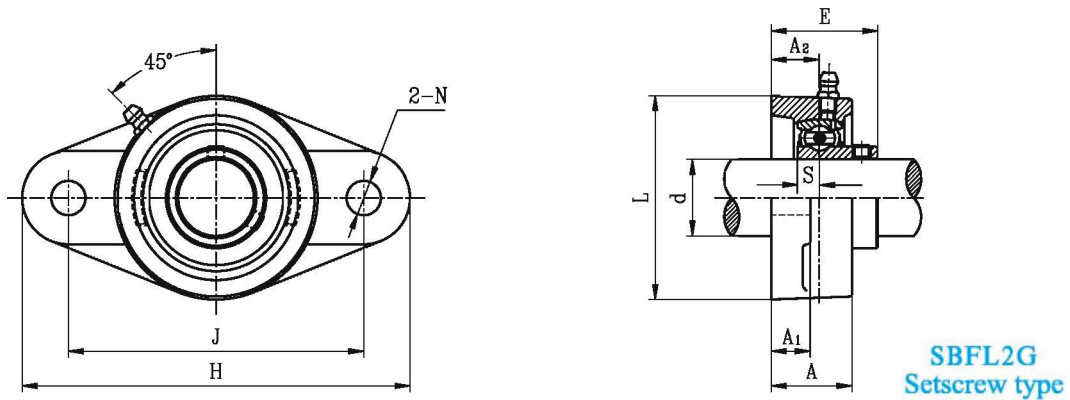

Unit No.	Shaft Dia.		Dimensions(mm).									Bolt Size	Bearing No.	Housing No.	Mass (kg)	Available
	d (in.)	d (mm)	H	J	L	A <sub>2</sub>	A <sub>1</sub>	A	E	N	S					
SBFL201G 201-8G 202G 202-10G 203G 203-11G	1/2 5/8 11/16	12 15 17	99	76.5	57	15	11	24.5	31	11.5	6	M10	SB201G 201-8G 202G 202-10G 203G 203-11G	FL203	0.36 0.35 0.34	--
SBFL204-12G 204G	3/4	20	113	90	60	15	11	25.5	33	11.5	7	M10	SB204-12G 204G	FL204	0.39	12
SBFL205-14G 205-15G 205G 205-16G	7/8 15/16 1	25	130	99	68	16	13	27	35.5	11.5	7.5	M10	SB205-14G 205-15G 205G 205-16G	FL205	0.58	16
SBFL206-18G 206G 206-19G 206-20G	1- 1/8 1- 3/16 1- 1/4	30	148	117	80	18	13	31	40	11.5	8	M10	SB206-18G 206G 206-19G 206-20G	FL206	0.84	16
SBFL207-20G 207-21G 207-22G 207G 207-23G	1- 1/4 1- 5/16 1- 3/8 1- 7/16	35	161	130	90	19	14	34	42.5	14	8.5	M12	SB207-20G 207-21G 207-22G 207G 207-23G	FL207	1.12	16
SBFL208-24G 208-25G 208G	1- 1/2 1- 9/16	40	175	144	100	21	14	36	46	14	9	M12	SB208-24G 208-25G 208G	FL208	1.40	16
SBFL209-26G 209-27G 209-28G 209G	1-5/8 1-11/16 1-3/4	45	188	148	108	22	16	38	53	18	10.2	M16	SB209-26G 209-27G 209-28G 209G	FL209	1.75	19
SBFL210-30G 210-31G 210G 210-32G	1-7/8 1-15/16 2	50	197	157	115	22	16	40	54.6	18	10.9	M16	SB210-30G 210-31G 210G 210-32G	FL210	2.04	19
SBFL211-32G 211-34G 211G 211-35G	2 2-1/8 2-3/16	55	224	184	130	25	18	43	58.5	18	11.8	M16	SB211-32G 211-34G 211G 211-35G	FL211	2.77	19
SBFL212-36G 212G 212-38G 212-39G	2-1/4 2-3/8 2-7/16	60	250	202	140	29	18	48	67.8	18	14.9	M16	SB212-36G 212G 212-38G 212-39G	FL212	3.51	23

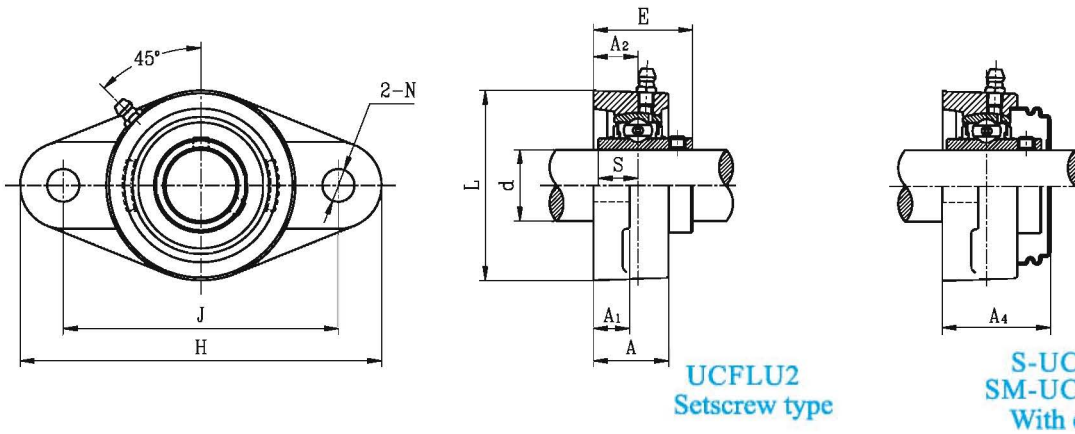

**UCFLU2**  
Setscrew type

**S-UCFLU200E1**  
**SM-UCFLU200E1**  
With end cover

Unit No.	Shaft Dia.		Dimensions(mm).										Bolt Size	Bearing No.	Housing No.	Mass (kg)
	d		H	J	L	A <sub>2</sub>	A <sub>1</sub>	A	E	N	S	A <sub>4</sub>				
	(in.)	(mm)														
UCFLU201S 201-8S 202S 202-10S 203S 203-11S	1/2 5/8 11/16	12 15 17	99	76.5	57	15	11	24.5	30.9	11.5	11.5	--	M10	UC201S 201-8S 202S 202-10S 203S 203-11S	FLU203	0.37 0.36 0.35
UCFLU201 201-8 202 202-10 203 203-11 204-12 204	1/2 5/8 11/16 3/4	12 15 17 20	112.5	90	61	19	15	29.5	37.3	11.5	12.7	41.5	M10	UC201 201-8 202 202-10 203 203-11 204-12 204	FLU204	0.53 0.51 0.50 0.48
UCFLU205-14 205-15 205 205-16	7/8 15/16 1	25	123	99	70	19	15	30	38.7	11.5	14.3	43	M10	UC205-14 205-15 205 205-16	FLU205	0.60
UCFLU206-18 206 206-19 206-20	1-1/8 1-3/16 1-1/4	30	142	116.5	82	20	16	32.5	42.2	11.5	15.9	46	M10	UC206-18 206 206-19 206-20	FLU206	0.87
UCFLU207-20 207-21 207 207-23	1-1/4 1-5/16 1-7/16	35	158	130	94	21	17	36	46.4	14	17.5	50.5	M12	UC207-20 207-21 207 207-23	FLU207	1.29
UCFLU208-24 208-25 208	1-1/2 1-9/16	40	172	143.5	130	24	17	39	54.2	14	19	58	M12	UC208-24 208-25 208	FLU208	1.59
UCFLU209-26 209-27 209-28 209	1-5/8 1-1/16 1-3/4	45	180	148.5	108	24	18	40	54.2	16	19	59	M14	UC209-26 209-27 209-28 209	FLU209	1.68
UCFLU210-30 210-31 210 210-32	1-7/8 1-15/16 2	50	190	157	114	28	20	45	60.6	18	19	66	M16	UC210-30 210-31 210 210-32	FLU210	2.01
UCFLU211-32 211-34 211 211-35	2 2-1/8 2-3/16	55	217	184	128	31	21	48	64.4	18	22.2	70	M16	UC211-32 211-34 211 211-35	FLU211	2.71
UCFLU212-36 212 212-38 212-39	2-1/4 2-3/8 2-7/16	60	237	202	138	34	21	53	73.7	18	25.4	79.5	M16	UC212-36 212 212-38 212-39	FLU212	3.46
UCFLU213-40 213	2-1/2	65	256	210	152	38	22	56	77.7	21	25.4	87	M18	UC213-40 213	FLU213	4.76
UCFLU214-44 214	2-3/4	70	264	216	157	38	23	58	82.4	21	30.2	--	M18	UC214-44 214	FLU214	5.70
UCFLU215-47 215 215-48	2-15/16 3	75	275	225	164	41	24	62	85.5	21	33.3	--	M18	UC215-47 215 215-48	FLU215	6.20

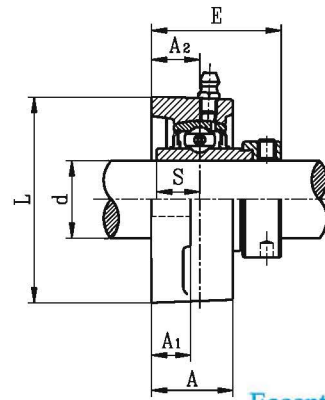
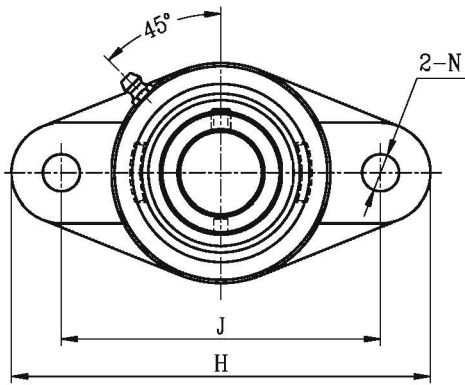

**NAFLU2**  
Eccentric locking collar type

Unit No.	Shaft Dia.		Dimensions(mm).									Bolt Size	Bearing No.	Housing No.	Mass (kg)
	d		H	J	L	A <sub>2</sub>	A <sub>1</sub>	A	E	N	S				
	(in.)	(mm)													
NAFLU201S 201- 8S 202S 202-10S 203S 203-11S	1/2 5/8 11/16	12 15 17											NA201S 201- 8S 202S 202-10S 203S 203-11S	FLU203	0.48 0.47 0.45
NAFLU201 201- 8 202 202-10 203 203-11 204-12 204	1/2 5/8 11/16 3/4	12 15 17 20	112.5	90	61	19	15	29.5	45.5	11.5	17	M10	NA201 201- 8 202 202-10 203 203-11 204-12 204	FLU204	0.60 0.57 0.56 0.53
NAFLU205-14 205-15 205 205-16	7/8 15/16 1	25	123	99	70	19	15	30	45.9	11.5	17.4	M10	NA205-14 205-15 205 205-16	FLU205	0.65
NAFLU206-18 206 206-19 206-20	1-1/8 1-3/16 1-1/4	30	142	116.5	82	20	16	32.5	50.1	11.5	18.2	M10	NA206-18 206 206-19 206-20	FLU206	0.94
NAFLU207-20 207-21 207-22 207 207-23	1-1/4 1-5/16 1-3/8 1-7/16	35	158	130	94	21	17	36	53.3	14	18.8	M12	NA207-20 207-21 207-22 207 207-23	FLU207	1.36
NAFLU208-24 208-25 208	1-1/2 1-9/16	40	172	143.5	103	24	17	39	58.9	14	21.4	M12	NA208-24 208-25 208	FLU208	1.70
NAFLU209-26 209-27 209-28 209	1-5/8 1-11/16 1-3/4	45	180	148.5	108	24	18	40	58.9	16	21.4	M14	NA209-26 209-27 209-28 209	FLU209	1.80
NAFLU210-30 210-31 210 210-32	1-7/8 1-15/16 2	50	190	157	114	28	20	45	66.1	18	24.6	M16	NA210-30 210-31 210 210-32	FLU210	2.18
NAFLU211-32 211-34 211 211-35	2 2-1/8 2-3/16	55	217	184	128	31	21	48	74.6	18	27.7	M16	NA211-32 211-34 211 211-35	FLU211	2.96
NAFLU212-36 212 212-38 212-39	2-1/4 2-3/8 2-7/16	60	237	202	138	34	21	53	80.8	18	30.9	M16	NA212-36 212 212-38 212-39	FLU212	3.74
NAFLU213-40 213	2-1/2	65	256	210	152	38	22	56	89.6	21	34.1	M18	NA213-40 213	FLU213	5.15
NAFLU214-44 214	2-3/4	70	264	216	157	38	23	58	89.6	21	34.1	M18	NA214-44 214	FLU214	5.74
NAFLU215-47 215 215-48	2-15/16 3	75	275	225	164	41	24	62	95.8	21	37.3	M18	NA215-47 215 215-48	FLU215	6.66

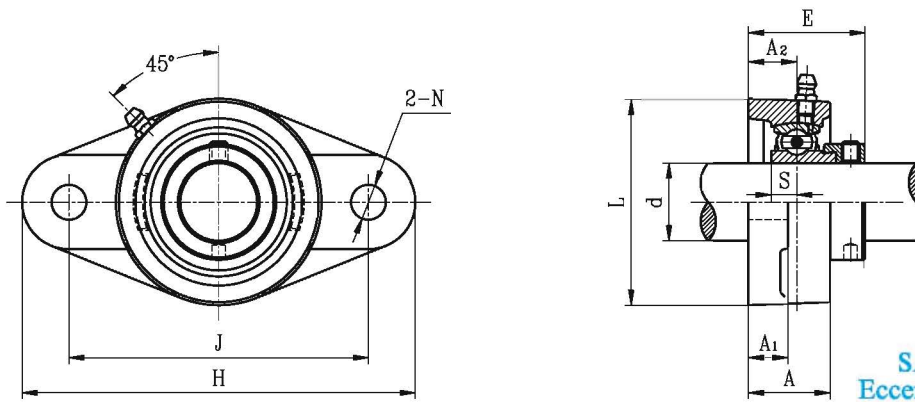

**SAFLU2G**  
Eccentric locking collar type

Unit No.	Shaft Dia.		Dimensions(mm).									Bolt Size	Bearing No.	Housing No.	Mass (kg)
	d (in.)	d (mm)	H	J	L	A <sub>2</sub>	A <sub>1</sub>	A	E	N	S				
SAFLU201G 201-8G 202G 202-10G 203G 203-11G	1/2 5/8 11/16	12 15 17	99	76.5	57	15	11	24.5	37.1	11.5	6.5	M10	SA201G 201-8G 202G 202-10G 203G 203-11G	FLU203	0.38 0.37 0.35
SAFLU204-12G 204G	3/4	20	112.5	90	61	19	15	29.5	42.4	11.5	7.5	M10	SA204-12G 204G	FLU204	0.48
SAFLU205-14G 205-15G 205G 205-16G	7/8 15/16 1	25	123	99	70	19	15	30	42.4	11.5	7.5	M10	SA205-14G 205-15G 205G 205-16G	FLU205	0.59
SAFLU206-18G 206G 206-19G 206-20G	1- 1/8 1- 3/16 1- 1/4	30	142	116.5	82	20	16	32.5	46.7	11.5	9	M10	SA206-18G 206G 206-19G 206-20G	FLU206	0.86
SAFLU207-20G 207-21G 207-22G 207G 207-23G	1- 1/4 1- 5/16 1- 3/8 1- 7/16	35	158	130	94	21	17	36	50.4	14	9.5	M12	SA207-20G 207-21G 207-22G 207G 207-23G	FLU207	1.26
SAFLU208-24G 208-25G 208G	1- 1/2 1- 9/16	40	172	143.5	103	24	17	39	56.7	14	11	M12	SA208-24G 208-25G 208G	FLU208	1.57
SAFLU209-26G 209-27G 209-28G 209G	1-5/8 1-11/16 1-3/4	45	180	148.5	108	24	18	40	56.7	56.7	11	M14	SA209-26G 209-27G 209-28G 209G	FLU209	1.66
SAFLU210-30G 210-31G 210G 210-32G	1-7/8 1-15/16 2	50	190	157	114	28	20	45	60.7	18	11	M16	SA210-30G 210-31G 210G 210-32G	FLU210	1.96
SAFLU211-32G 211-34G 211G 211-35G	2 2-1/8 2-3/16	55	217	184	128	31	21	48	67.4	18	12	M16	SA211-32G 211-34G 211G 211-35G	FLU211	2.71
SAFLU212-36G 212G 212-38G 212-39G	2-1/4 2-3/8 2-7/16	60	237	202	138	34	21	53	71.3	18	12	M16	SA212-36G 212G 212-38G 212-39G	FLU212	3.31

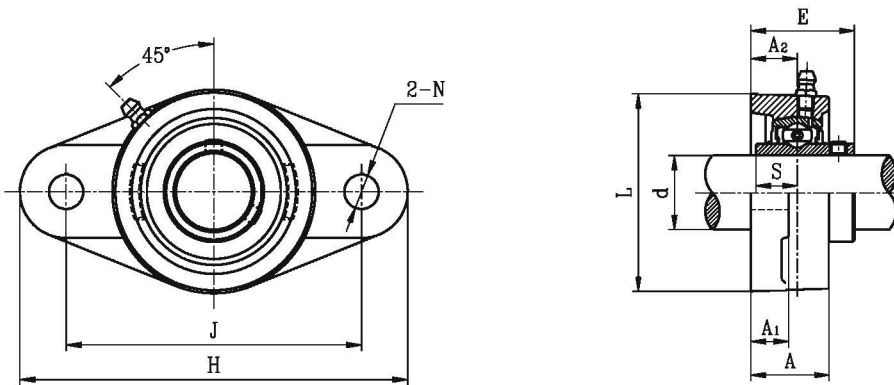

**UCFL3**  
Setscrew type

Unit No.	Shaft Dia.		Dimensions(mm).									Bolt Size	Bearing No.	Housing No.	Mass (kg)
	d		H	J	L	A <sub>2</sub>	A <sub>1</sub>	A	E	N	S				
	(in.)	(mm)													
UCFL305-14 305-15 305 305-16	7/8 15/16 1	25	150	113	80	16	13	29	39	19	15	M16	UC305-14 305-15 305 305-16	FL305	0.88
UCFL306-18 306 306-19	1- 1/8 1- 3/16	30	180	134	90	18	15	32	44	23	17	M20	UC306-18 306 306-19	FL306	1.32
UCFL307-20 307-21 307-22 307	1- 1/4 1- 5/16 1- 3/8	35	185	141	100	20	16	36	49	23	19	M20	UC307-20 307-21 307-22 307	FL307	1.65
UCFL308-24 308-25 308	1- 1/2 1- 9/16	40	200	158	112	23	17	40	56	23	19	M20	UC308-24 308-25 308	FL308	2.23
UCFL309-26 309-27 309-28 309	1- 5/8 1-11/16 1- 3/4	45	230	177	125	25	18	44	60	25	22	M22	UC309-26 309-27 309-28 309	FL309	3.01
UCFL310-30 310-31 310	1- 7/8 1-15/16	50	240	187	140	28	19	48	67	25	22	M22	UC310-30 310-31 310	FL310	3.94
UCFL311-32 311-34 311 311-35	2 2-1/8 2-3/16	55	250	198	150	30	20	52	71	25	25	M22	UC311-32 311-34 311 311-35	FL311	4.76
UCFL312-36 312 312-38 312-39	2-1/4 2-3/8 2-7/16	60	270	212	160	33	22	56	78	31	26	M27	UC312-36 312 312-38 312-39	FL312	5.64
UCFL313-40 313	2- 1/2	65	295	240	175	33	25	58	78	31	30	M27	UC313-40 313	FL313	7.0
UCFL314-44 314	2-3/4	70	315	250	185	36	28	61	83	35	31	M30	UC314-44 314	FL314	8.40
UCFL315 315-48	3	75	320	260	195	39	30	66	89	35	32	M30	UC315 315-48	FL315	9.63
UCFL316		80	355	285	210	38	32	68	90	38	34	M33	UC316	FL316	12.4

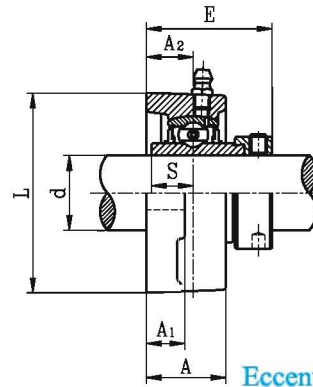
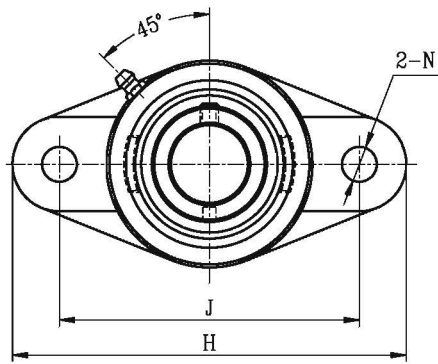

**NAFL3**  
Eccentric locking collar type

Unit No.	Shaft Dia.		Dimensions(mm).									Bolt Size	Bearing No.	Housing No.	Mass (kg)
	d		H	J	L	A <sub>2</sub>	A <sub>1</sub>	A	E	N	S				
	(in.)	(mm)													
NAFL305-14 305-15 305 305-16	7/8 15/16 1	25	150	113	80	16	13	29	46.1	19	16.7	M16	NA305-14 305-15 305 305-16	FL305	0.95
NAFL306-18 306 306-19	1- 1/8 1- 3/16	30	180	134	90	18	15	32	50.5	23	17.5	M20	NA306-18 306 306-19	FL306	1.46
NAFL307-20 307-21 307-22 307 307-23	1- 1/4 1- 5/16 1- 3/8 1- 7/16	35	185	141	100	20	16	36	53.3	23	18.3	M20	NA307-20 307-21 307-22 307 307-23	FL307	1.75
NAFL308-24 308-25 308	1- 1/2 1- 9/16	40	200	158	112	23	17	40	60.3	23	19.8	M20	NA308-24 308-25 308	FL308	2.37
NAFL309-26 309-27 309-28 309	1- 5/8 1-11/16 1- 3/4	45	230	177	125	25	18	44	63.9	25	19.8	M22	NA309-26 309-27 309-28 309	FL309	3.14
NAFL310-30 310-31 310	1- 7/8 1-15/16	50	240	187	140	28	19	48	70	25	24.6	M22	NA310-30 310-31 310	FL310	4.16
NAFL311-32 311-34 311 311-35	2 2-1/8 2-3/16	55	250	198	150	30	20	52	75.2	25	27.8	M22	NA311-32 311-34 311 311-35	FL311	5.01
NAFL312-36 312 312-38 312-39	2-1/4 2-3/8 2-7/16	60	270	212	160	33	22	56	80	31	30.95	M27	NA312-36 312 312-38 312-39	FL312	5.95
NAFL313-40 313	2- 1/2	65	295	240	175	33	25	58	86.2	31	32.5	M27	NA313-40 313	FL313	7.52
NAFL314-44 314	2-3/4	70	315	250	185	36	28	61	93.95	35	34.15	M30	NA314-44 314	FL314	9.06
NAFL315 315-48	3	75	320	260	195	39	30	66	101.7	35	37.3	M30	NA315 315-48	FL315	10.6
NAFL316		80	355	285	210	38	32	68	103.9	38	40.5	M33	NA316	FL316	13.5



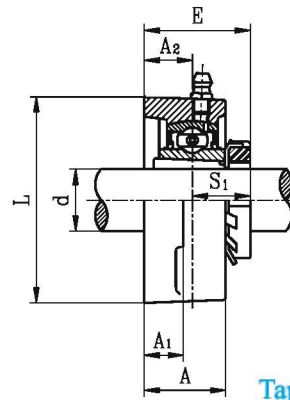
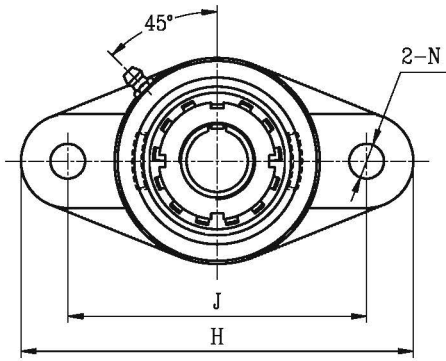

**UKFL3+H**  
Tapered bore, adapter type

Unit No.	Shaft Dia.		Dimensions(mm).									Bolt Size	Bearing No.	Housing No.	Adapter No.	Mass (kg)
	d		H	J	L	A <sub>2</sub>	A <sub>1</sub>	A	E	N	S <sub>1</sub>					
	(in.)	(mm)														
UKFL305+HE2305 305+H2305	3/4	20	150	113	80	16	13	29	37.5	19	21.5	M16	UK305	FL305	HE2305 H2305	0.93
UKFL306+HS2306 306+HA2306 306+H2306 306+HE2306	7/8 15/16 1	25	180	134	90	18	15	32	41	23	23	M20	UK306	FL306	HS2306 HA2306 H2306 HE2306	1.37
UKFL307+HS2307 307+H2307 307+HA2307	1-1/8 1-3/16	30	185	141	100	20	16	36	45.5	23	25.5	M20	UK307	FL307	HS2307 H2307 HA2307	1.69
UKFL308+HE2308 308+HS2308 308+H2308	1-1/4 1-3/8	35	200	158	112	23	17	40	50.5	23	27.5	M20	UK308	FL308	HE2308 HS2308 H2308	2.28
UKFL309+HA2309 309+HE2309 309+H2309	1-7/16 1-1/2	40	230	177	125	25	18	44	55	25	30	M22	UK309	FL309	HA2309 HE2309 H2309	3.15
UKFL310+HS2310 310+HA2310 310+HE2310 310+H2310	1-5/8 1-11/16 1-3/4	45	240	187	140	28	19	48	60	25	32	M22	UK310	FL310	HS2310 HA2310 HE2310 H2310	3.98
UKFL311+HS2311 311+HA2311 311+H2311 311+HE2311	1-7/8 1-15/16 2	50	250	198	150	30	20	52	63.5	25	33.5	M22	UK311	FL311	HS2311 HA2311 H2311 HE2311	4.78
UKFL312+HS2312 312+H2312	2-1/8	55	270	212	160	33	22	56	69.5	31	36.5	M27	UK312	FL312	HS2312 H2312	5.64
UKFL313+HA2313 313+HE2313 313+H2313 313+HS2313	2-3/16 2-1/4 2-3/8	60	295	240	175	33	25	58	71.5	31	38.5	M27	UK313	FL313	HA2313 HE2313 H2313 HS2313	6.96
UKFL315+HA2315 315+HE2315 315+H2315	2-7/16 2-1/2	65	320	260	195	39	30	66	81.5	35	42.5	M30	UK315	FL315	HA2315 HE2315 H2315	9.93
UKFL316+HA2316 316+HE2316 316+H2316	2-11/16 2-3/4	70	355	285	210	38	32	68	82.5	38	44.5	M33	UK316	FL316	HA2316 HE2316 H2316	12.6



# LIGHT-DUTY OVAL FLANGE UNITS(LF TYPE)

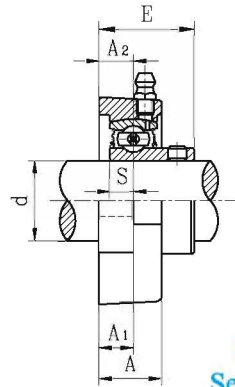
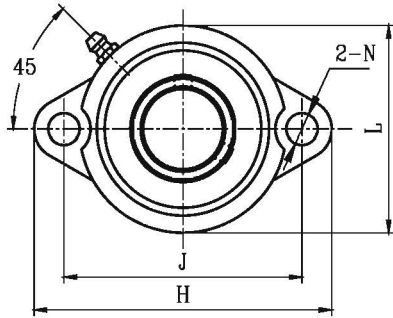

**SBLF2G**  
Setscrew type

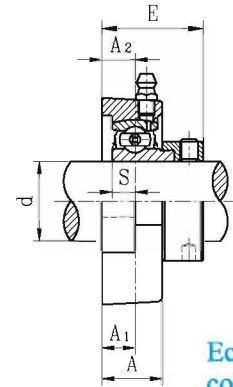

**SALF2G**  
Eccentric locking collar type

Unit No.	Shaft Dia.		Dimensions(mm).									Bolt Size		Bearing No.	Housing No.	Mass (kg)
	d		H	J	L	A <sub>1</sub>	A	A <sub>2</sub>	N	S	E					
	(in.)	(mm)														
SBLF201G 201-8G 202G 202-10G 203G 203-11G	1/2 5/8 11/16	12 15 17	81	63.5	56	9.5	18	9.5	8	6	25.5	M6	1/4	SB 201G 201-8G 202G 202-10G 203G 203-11G	LF203	0.29 0.28 0.27
SBLF204-12G 204G	3/4	20	90	71.5	61	11	20	11	10	7	29	M8	5/16	SB 204-12G 204G	LF204	0.32
SBLF205-14G 205-15G 205G 205-16G	7/8 15/16 1	25	95	76	64	11	20	11	10	7.5	30.5	M8	5/16	SB 205-14G 205-15G 205G 205-16G	LF205	0.36
SBLF206-18G 206G 206-19G 206-20G	1-1/8 1-3/16 1-1/4	30	113	90.5	76	12	22.5	12	12	8	34	M10	3/8	SB 206-18G 206G 206-19G 206-20G	LF206	0.57
SBLF207-20G 207-21G 207-22G 207G 207-23G	1-1/4 1-5/16 1-3/8 1-7/16	35	122	100	89	13	24	13	12	8.5	36.5	M10	3/8	SB 207-20G 207-21G 207-22G 207G 207-23G	LF207	0.78

Unit No.	Shaft Dia.		Dimensions(mm).									Bolt Size		Bearing No.	Housing No.	Mass (kg)
	d		H	J	L	A <sub>1</sub>	A	A <sub>2</sub>	N	S	E					
	(in.)	(mm)														
SALF201G 201-8G 202G 202-10G 203G 203-11G	1/2 5/8 11/16	12 15 17	81	63.5	56	9.5	18	9.5	8	6.5	31.6	M6	1/4	SA 201G 201-8G 202G 202-10G 203G 203-11G	LF203	0.31 0.30 0.28
SALF204-12G 204G	3/4	20	90	71.5	61	11	20	11	10	7.5	34.4	M8	5/16	SA 204-12G 204G	LF204	0..35
SALF205-14G 205-15G 205G 205-16G	7/8 15/16 1	25	95	76	64	11	20	11	10	7.5	34.4	M8	5/16	SA 205-14G 205-15G 205G 205-16G	LF205	0.38
SALF206-18G 206G 206-19G 206-20G	1-1/8 1-3/16 1-1/4	30	113	90.5	76	12	22.5	12	12	9	38.7	M10	3/8	SA 206-18G 206G 206-19G 206-20G	LF206	0.62
SALF207-20G 207-21G 207-22G 207G 207-23G	1-1/4 1-5/16 1-3/8 1-7/16	35	122	100	89	13	24	13	12	9.5	42.4	M10	3/8	SA 207-20G 207-21G 207-22G 207G 207-23G	LF207	0.84

Remarks: The numbers indicate relubricatable type. If maintenance free type is needed, please order without suffix "G".



# LIGHT-DUTY OVAL FLANGE UNITS(LFTC TYPE)

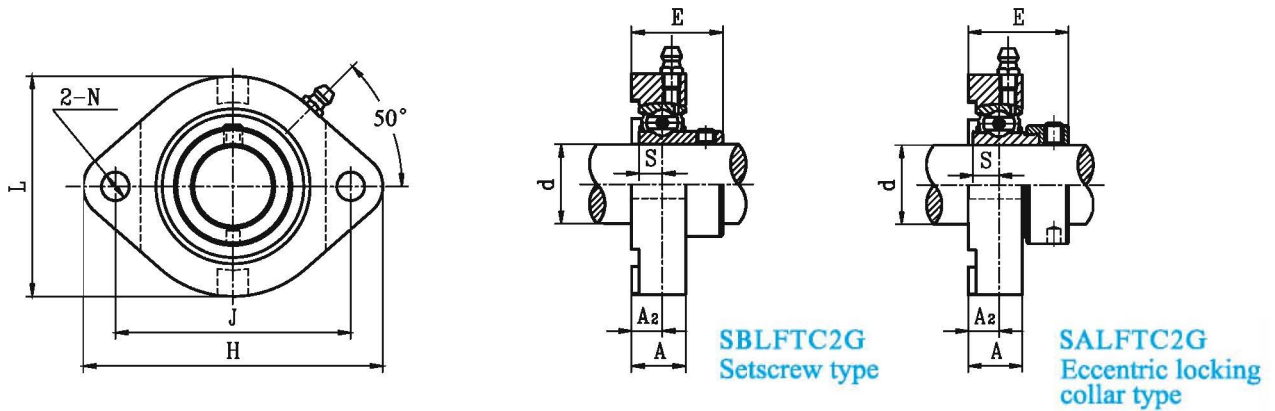

Unit No.	Shaft Dia.		Dimensions(mm).								Bolt Size		Bearing No.	Housing No.	Mass (kg)
	d		H	J	L	A	A <sub>2</sub>	N	S	E					
	(in.)	(mm)													
SBLFTC204-12G 204G	3/4	20	90.5	71.4	66.5	17	9.5	9	7	27.5	M8	5/16	SB204-12G 204G	LFTC20	0.37
SBLFTC205-14G 205-15G 205G 205-16G	7/8 15/16 1	25	97	76.2	71	17.5	9.9	9	7.5	29.4	M8	5/16	SB205-14G 205-15G 205G 205-16G	LFTC25	0.44
SBLFTC206-18G 206G 206-19G 206-20G	1-1/8 1-3/16 1-1/4	30	112.5	90.5	84	20.5	11.4	11	8	33.4	M10	3/8	SB206-18G 206G 206-19G 206-20G	LFTC30	0.66
SBLFTC207-20G 207-21G 207-22G 207G 207-23G	1-1/4 1-5/16 1-3/8 1-7/16	35	126	100	94	22	12.4	11	8.5	35.9	M10	3/8	SB207-20G 207-21G 207-22G 207G 207-23G	LFTC35	0.90
SBLFTC208-24G 208-25G 208G	1-1/2 1-9/16	40	148	119	104	24	14.1	14	9	39.1	M12	7/16	SB208-24G 208-25G 208G	LFTC40	1.22

Unit No.	Shaft Dia.		Dimensions(mm).								Bolt Size		Bearing No.	Housing No.	Mass (kg)
	d		H	J	L	A	A <sub>2</sub>	N	S	E					
	(in.)	(mm)													
SALFTC204-12G 204G	3/4	20	90.5	71.4	66.5	17	9.5	9	7.5	32.9	M8	5/16	SA204-12G 204G	LFTC20	0.40
SALFTC205-14G 205-15G 205G 205-16G	7/8 15/16 1	25	97	76.2	71	17.5	9.9	9	7.5	33.3	M8	5/16	SA205-14G 205-15G 205G 205-16G	LFTC25	0.46
SALFTC206-18G 206G 206-19G 206-20G	1-1/8 1-3/16 1-1/4	30	112.5	90.5	84	20.5	11.4	11	9	38.1	M10	3/8	SA206-18G 206G 206-19G 206-20G	LFTC30	0.71
SALFTC207-20G 207-21G 207-22G 207G 207-23G	1-1/4 1-5/16 1-3/8 1-7/16	35	126	100	94	22	12.4	11	9.5	41.8	M10	3/8	SA207-20G 207-21G 207-22G 207G 207-23G	LFTC35	0.96
SALFTC208-24G 208-25G 208G	1-1/2 1-9/16	40	148	119	104	24	14.1	14	11	46.8	M12	7/16	SA208-24G 208-25G 208G	LFTC40	1.35

Remarks: The numbers indicate relubricatable type. If maintenance free type is needed, please order without suffix "G".



# LIGHT-DUTY OVAL FLANGE UNITS(FD TYPE)

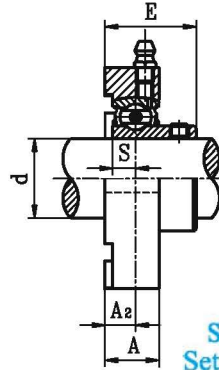
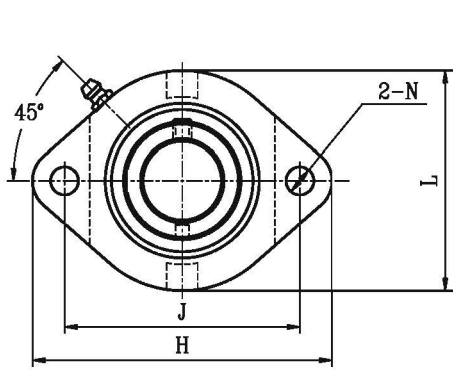

**SBFD2G**  
Setscrew type

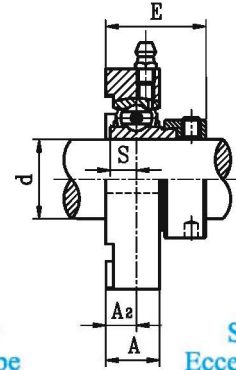

**SAFD2G**  
Eccentric locking collar type

Unit No.	Shaft Dia.		Dimensions(mm).								Bolt Size		Bearing No.	Housing No.	Mass (kg)
	d (in.)	d (mm)	H	J	L	A	A <sub>2</sub>	N	S	E					
SBFD201G 201-8G 202G 202-10G 203G 203-11G	1/2	12	81	63	59	15	8.5	7	6	24.5	M5	10-24	SB 201G 201-8G 202G 202-10G 203G 203-11G	FD203	0.30 0.29 0.28
	5/8	15													
		17													
	11/16														
SBFD204-12G 204G	3/4	20	90	71	67	17	9.5	10	7	27.5	M8	5/16	SB 204-12G 204G	FD204	0.37
SBFD205-14G 205-15G 205G 205-16G	7/8	25	95.2	76.2	71	17.5	9.5	10	7.5	29	M8	5/16	SB 205-14G 205-15G 205G 205-16G	FD205	0.43
	15/16														
	1														
SBFD206-18G 206G 206-19G 206-20G	1-1/8	30	113	90.5	84	21	12	12	8	34	M10	3/8	SB 206-18G 206G 206-19G 206-20G	FD206	0.67
	1-3/16														
	1-1/4														
SBFD207-20G 207-21G 207-22G 207G 207-23G	1-1/4	35	125	100	94	22	12.5	12	8.5	36	M10	3/8	SB 207-20G 207-21G 207-22G 207G 207-23G	FD207	0.92
	1-5/16														
	1-3/8														
	1-7/16														

Unit No.	Shaft Dia.		Dimensions(mm).								Bolt Size		Bearing No.	Housing No.	Mass (kg)
	d (in.)	d (mm)	H	J	L	A	A <sub>2</sub>	N	S	E					
SAFD201G 201-8G 202G 202-10G 203G 203-11G	1/2	12	81	63	59	15	8.5	7	6.5	30.6	M5	10-24	SA 201G 201-8G 202G 202-10G 203G 203-11G	FD203	0.32 0.31 0.29
	5/8	15													
		17													
	11/16														
SAFD204-12G 204G	3/4	20	90	71	67	17	9.5	10	7.5	32.9	M8	5/16	SA 204-12G 204G	FD204	0.40
SAFD205-14G 205-15G 205G 205-16G	7/8	25	95.2	76.2	71	17.5	9.5	10	7.5	32.9	M8	5/16	SA 205-14G 205-15G 205G 205-16G	FD205	0.45
	15/16														
	1														
SAFD206-18G 206G 206-19G 206-20G	1-1/8	30	113	90.5	84	21	12	12	9	38.7	M10	3/8	SA 206-18G 206G 206-19G 206-20G	FD206	0.72
	1-3/16														
	1-1/4														
SAFD207-20G 207-21G 207-22G 207G 207-23G	1-1/4	35	125	100	94	22	12.5	12	9.5	41.9	M10	3/8	SA 207-20G 207-21G 207-22G 207G 207-23G	FD207	0.98
	1-5/16														
	1-3/8														
	1-7/16														

Remarks: The numbers indicate relubricatable type. If maintenance free type is needed, please order without suffix "G".



# DUCTILE IRON OVAL FLANGE UNITS (PFTD TYPE)

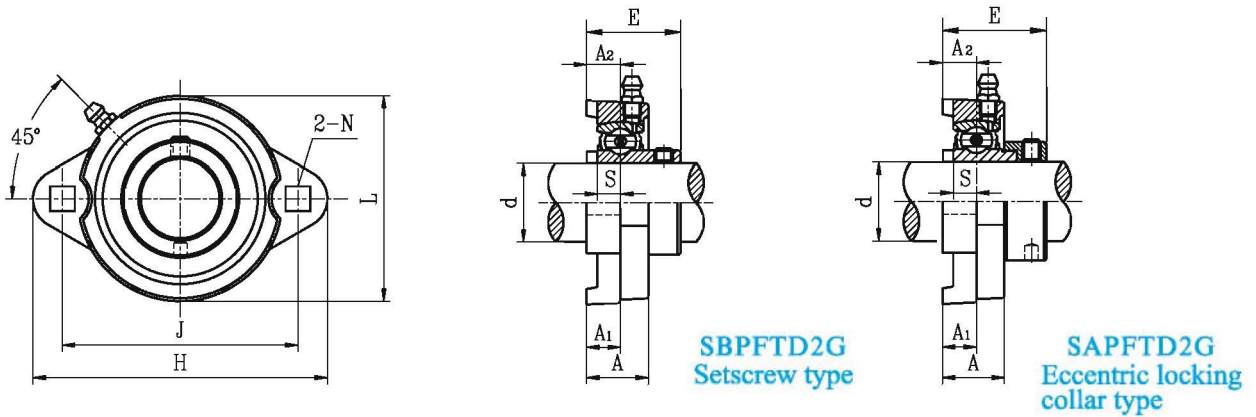

Unit No.	Shaft Dia.		Dimensions(mm).									Bolt Size		Bearing No.	Housing No.	Mass (kg)
	d (in.)	d (mm)	H	J	L	A <sub>1</sub>	A	A <sub>2</sub>	N	S	E					
SBPFTD201G 201-8G 202G 202-10G 203G 203-11G	1/2	12	81	63.5	56	9	18	9	8.7	6	25	M8	5/16	SB 201G 201-8G 202G 202-10G 203G 203-11G	PFTD203	0.26 0.25 0.24
	5/8	15														
	11/16	17														
	3/4	20														
SBPFTD204-12G 204G	3/4	20	91	71.5	63	10.2	20	10.2	8.7	7	28.2	M8	5/16	SB 204-12G 204G	PFTD204	0.29
	7/8	25	96	76.2	69	10.5	19	8.7	8.7	7.5	28.2	M8	5/16	SB 205-14G 205-15G 205G 205-16G	PFTD205	0.39
SBPFTD205-14G 205-15G 205G 205-16G	15/16	25	113	90.5	79	11.5	22	11.5	10.3	8	33.5	M10	3/8	SB 206-18G 206G 206-19G 206-20G	PFTD206	0.51
	1	30														
	1-1/8	30														
SBPFTD206-18G 206G 206-19G 206-20G	1-1/8	30	122.5	100	89	12.7	23.8	11.8	10.3	8.5	35.3	M10	3/8	SB 207-20G 207-21G 207-22G 207G 207-23G	PFTD207	0.75
	1-3/16	35														
	1-1/4	35														
	1-7/16	35														

Unit No.	Shaft Dia.		Dimensions(mm).									Bolt Size		Bearing No.	Housing No.	Mass (kg)
	d (in.)	d (mm)	H	J	L	A <sub>1</sub>	A	A <sub>2</sub>	N	S	E					
SAPFTD201G 201-8G 202G 202-10G 203G 203-11G	1/2	12	81	63.5	56	9	18	9	8.7	6.5	31.1	M8	5/16	SA 201G 201-8G 202G 202-10G 203G 203-11G	PFTD203	0.28 0.27 0.25
	5/8	15														
	11/16	17														
	3/4	20														
SAPFTD204-12G 204G	3/4	20	91	71.5	63	10.2	20	10.2	8.7	7.5	33.6	M8	5/16	SA 204-12G 204G	PFTD204	0.32
SAPFTD205-14G 205-15G 205G 205-16G	7/8	25	96	76.2	69	10.5	19	8.7	8.7	7.5	32.1	M8	5/16	SA 205-14G 205-15G 205G 205-16G	PFTD205	0.41
	15/16	25														
SAPFTD206-18G 206G 206-19G 206-20G	1	30	113	90.5	79	11.5	22	11.5	10.3	9	38.2	M10	3/8	SA 206-18G 206G 206-19G 206-20G	PFTD206	0.56
	1-1/8	30														
	1-3/16	30														
SAPFTD207-20G 207-21G 207-22G 207G 207-23G	1-1/4	35	122.5	100	89	12.7	23.8	11.8	10.3	9.5	41.2	M10	3/8	SA 207-20G 207-21G 207-22G 207G 207-23G	PFTD207	0.81
	1-5/16	35														
	1-3/8	35														
	1-7/16	35														

Remarks: The numbers indicate relubricatable type. If maintenance free type is needed, please order without suffix "G".



# DUCTILE IRON FLANGE UNITS (FCT TYPE)

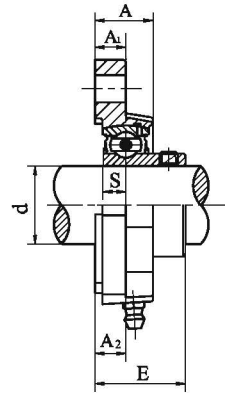
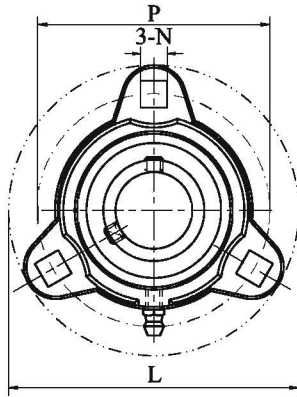

**SBFCT2G**  
Setscrew type

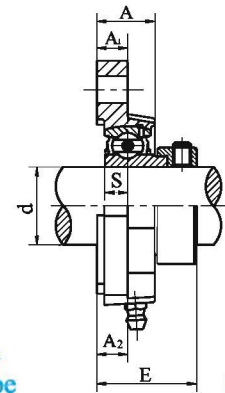

**SAFCT2G**  
Eccentric locking collar type

Unit No.	Shaft Dia.		Dimensions(mm).									Bolt Size		Bearing No.	Housing No.	Mass (kg)
	d		L	P	A1	A	A2	N	S	E						
	(in.)	(mm)														
SBFCT 201G 201-8G 202G 202-10G 203G 203-11G	1/2 5/8 11/16	12 15 17	81	63.5	10.7	19.1	10.7	7.1	6	26.7	M6	1/4	SB 201G 201-8G 202G 202-10G 203G 203-11G	FCT203	0.24 0.23 0.22	
SBFCT 204-12G 204G	3/4	20	90.5	71.4	11.1	19.8	11.1	8.7	7	29.1	M8	5/16	SB 204-12G 204G	FCT204	0.32	
SBFCT 205-14G 205-15G 205G 205-16G	7/8 15/16 1	25	95.2	76.2	10.3	19.8	10.3	8.7	7.5	29.8	M8	5/16	SB 205-14G 205-15G 205G 205-16G	FCT205	0.37	
SBFCT 206-18G 206G 206-19G 206-20G	1-1/8 1-3/16 1-1/4	30	113	90.5	12	22	12	10.3	8	34	M10	3/8	SB 206-18G 206G 206-19G 206-20G	FCT206	0.51	
SBFCT 207-20G 207-21G 207-22G 207G 207-23G	1-1/4 1-5/16 1-3/8 1-7/16	35	122.5	100	12.7	23.8	12.7	10.3	8.5	36.2	M10	3/8	SB 207-20G 207-21G 207-22G 207G 207-23G	FCT207	0.75	

Unit No.	Shaft Dia.		Dimensions(mm).									Bolt Size		Bearing No.	Housing No.	Mass (kg)
	d		L	P	A1	A	A2	N	S	E						
	(in.)	(mm)														
SAFCT 201G 201-8G 202G 202-10G 203G 203-11G	1/2 5/8 11/16	12 15 17	81	63.5	10.7	19.1	10.7	7.1	6.5	32.8	M6	1/4	SA 201G 201-8G 202G 202-10G 203G 203-11G	FCT203	0.26 0.25 0.23	
SAFCT 204-12G 204G	3/4	20	90.5	71.4	11.1	19.8	11.1	8.7	7.5	34.5	M8	5/16	SA 204-12G 204G	FCT204	0.35	
SAFCT 205-14G 205-15G 205G 205-16G	7/8 15/16 1	25	95.2	76.2	10.3	19.8	10.3	8.7	7.5	33.7	M8	5/16	SA 205-14G 205-15G 205G 205-16G	FCT205	0.39	
SAFCT 206-18G 206G 206-19G 206-20G	1-1/8 1-3/16 1-1/4	30	113	90.5	12	22	12	10.3	9	38.7	M10	3/8	SA 206-18G 206G 206-19G 206-20G	FCT206	0.39	
SAFCT 207-20G 207-21G 207-22G 207G 207-23G	1-1/4 1-5/16 1-3/8 1-7/16	35	122.5	100	12.7	23.8	12.7	10.3	9.5	42.1	M10	3/8	SA 207-20G 207-21G 207-22G 207G 207-23G	FCT207	0.81	

Remarks: The numbers indicate relubricatable type. If maintenance free type is needed, please order without suffix "G".



# PRESSED-STEEL OVAL FLANGE UNITS

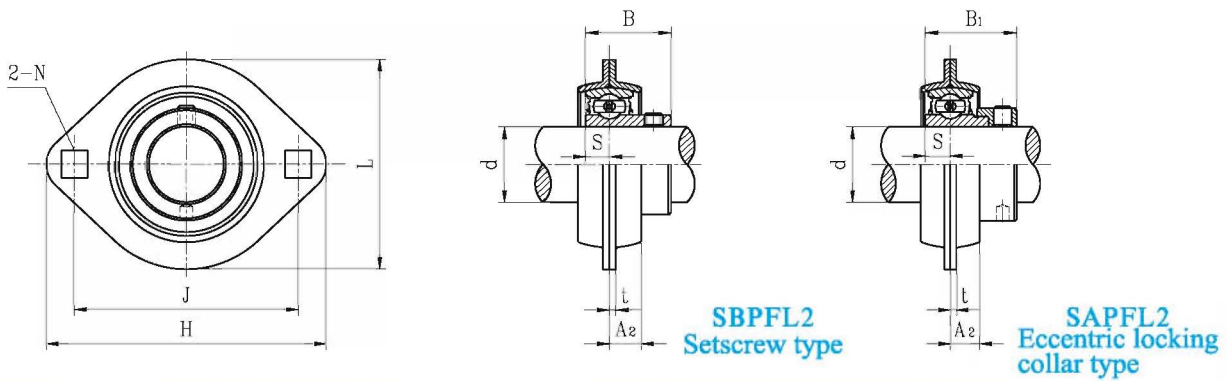

Unit No.	Shaft Dia.		Dimensions(mm).								Bolt Size		Bearing No.	Housing No.	Mass (kg)
	d		H	J	A <sub>2</sub>	L	N	t	S	B					
	(in.)	(mm)													
SBPFL201 201-8 202 202-10 203 203-11	1/2	12	81	63.5	7	59	7.5	2	6	22	M6	1/4	SB201 201-8 202 202-10 203 203-11	PFL203	0.18 0.17 0.16
	5/8	15													
	11/16	17													
	3/4	20													
	7/8	25													
SBPFL204-12 204	15/16	25	90	71.5	8	67	9	2	7	25	M8	5/16	SB204-12 204	PFL204	0.22
	1	30													
	1-1/8	30													
	1-3/16	30													
SBPFL205-14 205-15 205 205-16	1-1/4	30	95	76	9	71	9	2	7.5	27	M8	5/16	SB205-14 205-15 205 205-16	PFL205	0.27
	1-5/16	35													
	1-3/8	35													
	1-7/16	35													
	1-1/2	40													
SBPFL206-18 206 206-19 206-20	1-9/16	40	113	90.5	9	84	10.5	2.5	8	30	M10	3/8	SB206-18 206 206-19 206-20	PFL206	0.41
	1-1/4	35													
	1-5/16	35													
	1-3/8	35													
	1-7/16	35													
SBPFL207-20 207-21 207-22 207 207-23	1-1/2	40	122	100	10	94	10.5	2.5	8.5	32	M10	3/8	SB207-20 207-21 207-22 207 207-23	PFL207	0.58
	1-9/16	40													
	1-1/2	40													
	1-9/16	40													
	1-1/2	40													
SBPFL208-24 208-25 208	1-1/2	40	148	119	12	100	13.5	3.5	9	34	M12	1/2	SB208-24 208-25 208	PFL208	0.81
	1-9/16	40													
	1-1/2	40													

Unit No.	Shaft Dia.		Dimensions(mm).								Bolt Size		Bearing No.	Housing No.	Mass (kg)
	d		H	J	A <sub>2</sub>	L	N	t	S	B <sub>1</sub>					
	(in.)	(mm)													
SAPFL 201 201-8 202 202-10 203 203-11	1/2	12	81	63.5	7	59	7.5	2	6.5	28.6	M6	1/4	SA201 201-8 202 202-10 203 203-11	PFL203	0.20 0.19 0.17
	5/8	15													
	11/16	17													
	3/4	20													
	7/8	25													
SAPFL 204-12 204	15/16	25	90	71.5	8	67	9	2	7.5	30.9	M8	5/16	SA204-12 204	PFL204	0.25
	1	30													
	1-1/8	30													
	1-3/16	30													
SAPFL 205-14 205-15 205 205-16	1-1/4	30	95	76	9	71	9	2	7.5	30.9	M8	5/16	SA205-14 205-15 205 205-16	PFL205	0.29
	1-5/16	35													
	1-3/8	35													
	1-7/16	35													
	1-1/2	40													
SAPFL 206-18 206 206-19 206-20	1-9/16	40	113	90.5	9	84	10.5	2.5	9	35.7	M10	3/8	SA206-18 206 206-19 206-20	PFL206	0.46
	1-1/4	35													
	1-5/16	35													
	1-3/8	35													
	1-7/16	35													
SAPFL 207-20 207-21 207-22 207 207-23	1-1/2	40	122	100	10	94	10.5	2.5	9.5	38.9	M10	3/8	SA207-20 207-21 207-22 207 207-23	PFL207	0.64
	1-9/16	40													
	1-1/2	40													
	1-9/16	40													
	1-1/2	40													
SAPFL208-24 208-25 208	1-1/2	40	148	119	12	100	13.5	3.5	11	43.7	M12	1/2	SA208-24 208-25 208	PFL208	0.94
	1-9/16	40													
	1-1/2	40													



# ROUND FLANGE CARTRIDGE UNITS

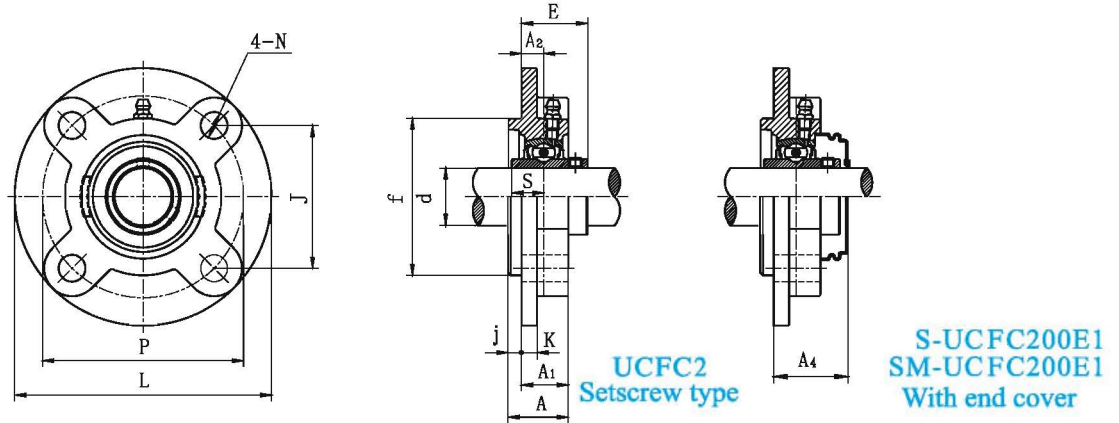

Unit No.	Shaft Dia.		Dimensions(mm).													Bolt Size	Bearing No.	Housing No.	Mass (kg)
	d (in.)	d (mm)	L	P	A <sub>2</sub>	A <sub>1</sub>	A	j	K	N	J	f	S	E	A <sub>4</sub>				
UCFC201S 201-8S 202S 202-10S 203S 203-11S	1/2 5/8 11/16	12 15 17	90	70	10	19	23	4	5	10	49.5	55	11.5	25.9	--	M8	UC201S 201-8S 202S 202-10S 203S 203-11S	FC203	0.53 0.52 0.51
UCFC201 201-8 202 202-10 203 203-11 204-12 204	1/2 5/8 11/16 3/4	12 15 17 20	100	78	10	20.5	25.5	5	6	12	55.1	62	12.7	28.3	32.5	M10	UC201 201-8 202 202-10 203 203-11 204-12 204	FC204	0.72 0.70 0.69 0.67
UCFC205-14 205-15 205 205-16	7/8 15/16 1	25	115	90	10	21	27	6	7	12	63.6	70	14.3	29.7	34	M10	UC205-14 205-15 205 205-16	FC205	0.98
UCFC206-18 206 206-19 206-20	1-1/8 1-3/16 1-1/4	30	125	100	10	23	31	8	8	12	70.7	80	15.9	32.2	36	M10	UC206-18 206 206-19 206-20	FC206	1.33
UCFC207-20 207-21 207-22 207 207-23	1-1/4 1-5/16 1-3/8 1-7/16	35	135	110	11	26	34	8	9	14	77.8	90	17.5	36.4	40.5	M12	UC207-20 207-21 207-22 207 207-23	FC207	1.64
UCFC208-24 208-25 208	1-1/2 1-9/16	40	145	120	11	26	36	10	9	14	84.8	100	19	41.2	45	M12	UC208-24 208-25 208	FC208	2.04
UCFC209-26 209-27 209-28 209	1-5/8 1-11/16 1-3/4	45	160	132	10	26	38	12	10	16	93.3	105	19	40.2	45	M14	UC209-26 209-27 209-28 209	FC209	2.40
UCFC210-30 210-31 210	1-7/8 1-15/16	50	165	138	10	28	40	12	14	16	97.6	110	19	42.6	48	M14	UC210-30 210-31 210	FC210	2.83
UCFC211-32 211-34 211 211-35	2 2-1/8 2-3/16	55	185	150	13	30	42	12	13	19	106.1	125	22.2	46.4	52	M16	UC211-32 211-34 211 211-35	FC211	3.82
UCFC212-36 212 212-38 212-39	2-1/4 2-3/8 2-7/16	60	195	160	17	36	48	12	15	19	113.1	135	25.4	56.7	62.5	M16	UC212-36 212 212-38 212-39	FC212	4.84
UCFC213-40 213	2-1/2	65	205	170	16	35	49	14	15	19	120.2	145	25.4	55.7	65	M16	UC213-40 213	FC213	5.43
UCFC214-44 214	2-3/4	70	215	177	17	38	52	14	16	19	125.1	150	30.2	61.4	--	M16	UC214-44 214	FC214	6.28
UCFC215 215-48	3	75	220	184	18	39	55	16	17	19	130.1	160	33.3	62.5	--	M16	UC215 215-48	FC215	7.18
UCFC216		80	240	200	18	42	58	16	18	23	141.4	170	33.3	67.3	--	M20	UC216	FC216	9.17
UCFC217-52 217	3-1/4	85	250	208	18	45	63	18	20	23	147.1	180	34.1	69.6	--	M20	UC217-52 217	FC217	10.6
UCFC218-56 218	3-1/2	90	265	220	22	50	68	18	20	23	155.5	190	39.7	78.3	--	M20	UC218-56 218	FC218	12.6





# ROUND FLANGE CARTRIDGE UNITS

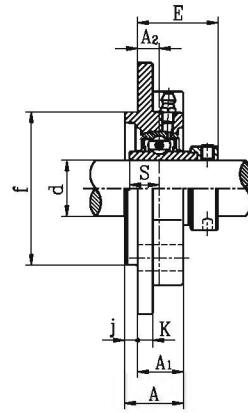
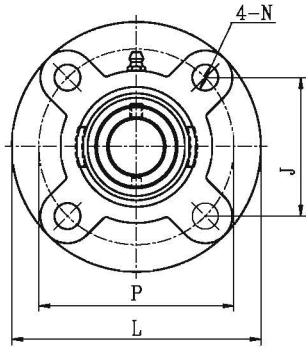

NAFC2  
Eccentric locking collar type

Unit No.	Shaft Dia.		Dimensions(mm).											Bolt Size	Bearing No.	Housing No.	Mass (kg)	
	d (in.)	d (mm)	L	P	A <sub>2</sub>	A <sub>1</sub>	A	j	K	N	J	f	S					E
NAFC201S 201-8S 202S 202-10S 203S 203-11S	1/2 5/8 11/16	12 15 17	90	70	10	19	23	4	5	10	49.5	55	13.9	33.4	M8	NA201S 201-8S 202S 202-10S 203S 203-11S	FC203	0.64 0.63 0.61
NAFC201 201-8 202 202-10 203 203-11 204-12 204	1/2 5/8 11/16 3/4	12 15 17 20	100	78	10	20.5	25.5	5	6	12	55.1	62	17	36.5	M10	NA201 201-8 202 202-10 203 203-11 204-12 204	FC204	0.79 0.76 0.75 0.72
NAFC205-14 205-15 205 205-16	7/8 15/16 1	25	115	90	10	21	27	6	7	12	63.6	70	17.4	36.9	M10	NA205-14 205-15 205 205-16	FC205	1.03
NAFC206-18 206 206-19 206-20	1-1/8 1-3/16 1-1/4	30	125	100	10	23	31	8	8	12	70.7	80	18.2	40.1	M10	NA206-18 206 206-19 206-20	FC206	1.40
NAFC207-20 207-21 207-22 207 207-23	1-1/4 1-5/16 1-3/8 1-7/16	35	135	110	11	26	34	8	9	14	77.8	90	18.8	43.3	M12	NA207-20 207-21 207-22 207 207-23	FC207	1.71
NAFC208-24 208-25 208	1-1/2 1-9/16	40	145	120	11	26	36	10	9	14	84.8	100	21.4	45.9	M12	NA208-24 208-25 208	FC208	2.15
NAFC209-26 209-27 209-28 209	1-5/8 1-11/16 1-3/4	45	160	132	10	26	38	12	10	16	93.3	105	21.4	44.9	M14	NA209-26 209-27 209-28 209	FC209	2.52
NAFC210-30 210-31 210	1-7/8 1-15/16	50	165	138	10	28	40	12	14	16	97.6	110	24.6	48.1	M14	NA210-30 210-31 210	FC210	3.00
NAFC211-32 211-34 211 211-35	2 2-1/8 2-3/16	55	185	150	13	30	42	12	13	19	106.1	125	27.7	56.6	M16	NA211-32 211-34 211 211-35	FC211	4.07
NAFC212-36 212 212-38 212-39	2-1/4 2-3/8 2-7/16	60	195	160	17	36	48	12	15	19	113.1	135	30.9	63.8	M16	NA212-36 212 212-38 212-39	FC212	5.12
NAFC213-40 213	2-1/2	65	205	170	16	35	49	14	15	19	120.2	145	34.1	67.6	M16	NA213-40 213	FC213	5.82
NAFC214-44 214	2-3/4	70	215	177	17	38	52	14	16	19	125.1	150	34.1	68.6	M16	NA214-44 214	FC214	6.32
NAFC215 215-48	3	75	220	184	18	39	55	16	17	19	130.1	160	37.3	72.8	M16	NA215 215-48	FC215	7.64
NAFC216		80	240	200	18	42	58	16	18	23	141.4	170	37.3	75.9	M20	NA216	FC216	9.79
NAFC217-52 217	3-1/4	85	250	208	18	45	63	18	20	23	147.1	180	23.4	67.8	M20	NA217-52 217	FC217	10.8
NAFC218-56 218	3-1/2	90	265	220	22	50	68	18	20	23	155.5	190	24.5	70	M20	NA218-56 218	FC218	12.3

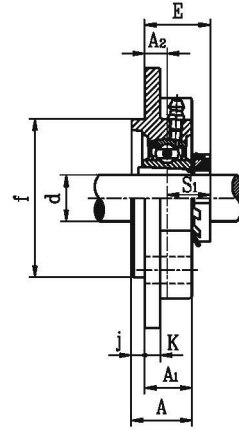
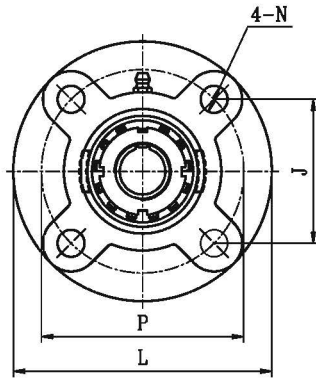

**UKFC2+H**  
Tapered bore, adapter type

Unit No.	Shaft Dia.		Dimensions(mm).													Bolt Size	Bearing No.	Housing No.	Adapter No.	Mass (kg)
	d		L	P	A <sub>2</sub>	A <sub>1</sub>	A	j	K	N	J	f	S <sub>1</sub>	E						
	(in.)	(mm)																		
UKFC205+HE2305 205+H2305	3/4	20	115	90	10	21	27	6	7	12	63.6	70	18.5	28.5	M10	UK205	FC205	HE2305 H2305	1.02	
UKFC206+HS2306 206+HA2306 206+H2306 206+HE2306	7/8 15/16 1	25	125	100	10	23	31	8	8	12	70.7	80	20.5	30.5	M10	UK206	FC206	HS2306 HA2306 H2306 HE2306	1.40	
UKFC207+HS2307 207+H2307 207+HA2307	1-1/8 1-3/16	30	135	110	11	26	34	8	9	14	77.8	90	22.5	33.5	M12	UK207	FC207	HS2307 H2307 HA2307	1.69	
UKFC208+HE2308 208+HS2308 208+H2308	1-1/4 1-3/8	35	145	120	11	26	36	10	9	14	84.8	100	24.5	35.5	M12	UK208	FC208	HE2308 HS2308 H2308	2.10	
UKFC209+HA2309 209+HE2309 209+H2309	1-7/16 1-1/2	40	160	132	10	26	38	12	10	16	93.3	105	26	36	M14	UK209	FC209	HA2309 HE2309 H2309	2.51	
UKFC210+HS2310 210+HA2310 210+HE2310 210+H2310	1-5/8 1-11/16 1-3/4	45	165	138	10	28	40	12	14	16	97.6	110	27.5	37.5	M14	UK210	FC210	HS2310 HA2310 HE2310 H2310	3.01	
UKFC211+HS2311 211+HA2311 211+H2311 211+HE2311	1-7/8 1-15/16 2	50	185	150	13	30	42	12	13	19	106.1	125	28.5	41.5	M16	UK211	FC211	HS2311 HA2311 H2311 HE2311	3.98	
UKFC212+HS2312 212+H2312	2-1/8	55	195	160	17	36	48	12	15	19	113.1	135	31	48	M16	UK212	FC212	HS2312 H2312	4.94	
UKFC213+HA2313 213+HE2313 213+H2313 213+HS2313	2-3/16 2-1/4 2-3/8	60	205	170	16	35	49	14	15	19	120.2	145	32	48	M16	UK213	FC213	HA2313 HE2313 H2313 HS2313	5.51	
UKFC215+HA2315 215+HE2315 215+H2315	2-7/16 2-1/2	65	220	184	18	39	55	16	17	19	130.1	160	35.5	53.5	M16	UK215	FC215	HA2315 HE2315 H2315	7.55	
UKFC216+HA2316 216+HE2316 216+H2316	2-11/16 2-3/4	70	240	200	18	42	58	16	18	23	141.4	170	39	57	M20	UK216	FC216	HA2316 HE2316 H2316	9.64	
UKFC217+HA2317 217+H2317 217+HE2317	2-15/16 3	75	250	208	18	45	63	18	20	23	147.1	180	40	58	M20	UK217	FC217	HA2317 H2317 HE2317	11.0	
UKFC218+H2318		80	265	220	22	50	68	18	20	23	155.5	190	42	64	M20	UK218	FC218	H2318	13.0	



# PRESSED HOUSING ROUND FLANGE UNITS

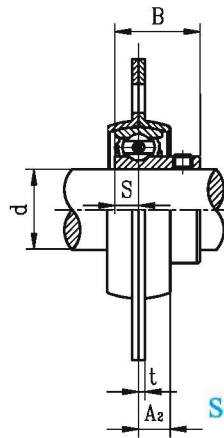
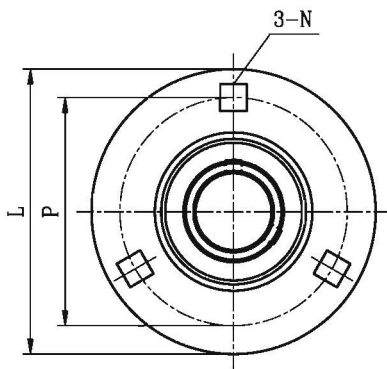

**SBPF2**  
Setscrew type

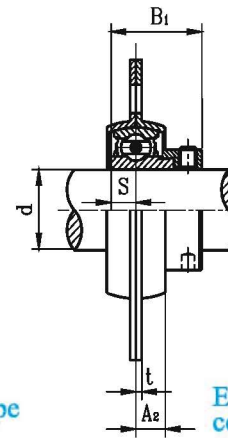

**SAPF2**  
Eccentric locking collar type

Unit No.	Shaft Dia.		Dimensions(mm).							Bolt Size		Bearing No.	Housing No.	Mass (kg)
	d		L	P	A <sub>2</sub>	t	N <sup>Ø</sup>	S	B					
	(in.)	(mm)												
SBPF201	1/2	12	82	64	7	2	7.5	6	22	1/4	M6	SB201	PF203	0.24
201-8		15												
202	5/8	17	82	64	7	2	7.5	6	22	1/4	M6	SB202	PF203	0.23
202-10		0.22												
203	11/16	17	82	64	7	2	7.5	6	22	1/4	M6	SB203	PF203	0.22
203-11		0.22												
SBPF204-12	3/4	20	91	71	8	2	9	7	25	5/16	M8	SB204-12	PF204	0.29
204		0.29												
SBPF205-14	7/8	25	95	76	9	2	9	7.5	27	5/16	M8	SB205-14	PF205	0.35
205-15		0.35												
205	1	25	95	76	9	2	9	7.5	27	5/16	M8	SB205-15	PF205	0.35
205-16		0.35												
SBPF206-18	1-1/8	30	113	90	9	2.5	10.5	8	30	3/8	M10	SB206-18	PF206	0.55
206		0.55												
206-19	1-3/16	30	113	90	9	2.5	10.5	8	30	3/8	M10	SB206-19	PF206	0.55
206-20		0.55												
SBPF207-20	1-1/4	35	122	100	10	2.5	10.5	8.5	32	3/8	M10	SB207-20	PF207	0.73
207-21		0.73												
207-22	1-5/16	35	122	100	10	2.5	10.5	8.5	32	3/8	M10	SB207-21	PF207	0.73
207		0.73												
207-23	1-7/16	35	122	100	10	2.5	10.5	8.5	32	3/8	M10	SB207-22	PF207	0.73
207		0.73												
SBPF208-24	1-1/2	40	148	119	12	3.5	13.5	9	34	1/2	M12	SB208-24	PF208	1.18
208-25		1.18												
208	1.18													

Unit No.	Shaft Dia.		Dimensions(mm).							Bolt Size		Bearing No.	Housing No.	Mass (kg)
	d		L	P	A <sub>2</sub>	t	N <sup>Ø</sup>	S	B <sub>1</sub>					
	(in.)	(mm)												
SAPF201	1/2	12	82	64	7	2	7.5	6.5	28.6	1/4	M6	SA201	PF203	0.26
201-8		0.26												
202	5/8	15	82	64	7	2	7.5	6.5	28.6	1/4	M6	SA202	PF203	0.25
202-10		0.25												
203	11/16	17	82	64	7	2	7.5	6.5	28.6	1/4	M6	SA203	PF203	0.23
203-11		0.23												
SAPF204-12	3/4	20	91	71	8	2	9	7.5	30.9	5/16	M8	SA204-12	PF204	0.32
204		0.32												
SAPF205-14	7/8	25	95	76	9	2	9	7.5	30.9	5/16	M8	SA205-14	PF205	0.37
205-15		0.37												
205	1	25	95	76	9	2	9	7.5	30.9	5/16	M8	SA205-15	PF205	0.37
205-16		0.37												
SAPF206-18	1-1/8	30	113	90	9	2.5	10.5	9	35.7	3/8	M10	SA206-18	PF206	0.60
206		0.60												
206-19	1-3/16	30	113	90	9	2.5	10.5	9	35.7	3/8	M10	SA206-19	PF206	0.60
206-20		0.60												
SAPF207-20	1-1/4	35	122	100	10	2.5	10.5	9.5	38.9	3/8	M10	SA207-20	PF207	0.79
207-21		0.79												
207-22	1-5/16	35	122	100	10	2.5	10.5	9.5	38.9	3/8	M10	SA207-21	PF207	0.79
207		0.79												
207-23	1-7/16	35	122	100	10	2.5	10.5	9.5	38.9	3/8	M10	SA207-22	PF207	0.79
207		0.79												
SAPF208-24	1-1/2	40	148	119	12	3.5	13.5	11	43.7	1/2	M12	SA208-24	PF208	1.31
208-25		1.31												
208	1.31													

Remarks:⊙ SBPF208 and SAPF208 have four bolt holes.



# PRESSED HOUSING FLANGE UNITS(PFT TYPE)

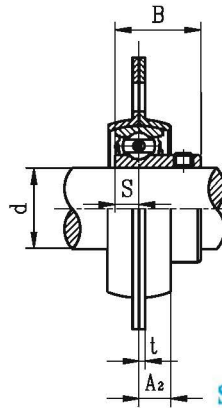
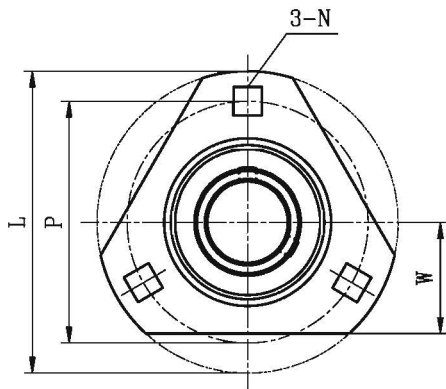

**SBPFT2**  
Setscrew type

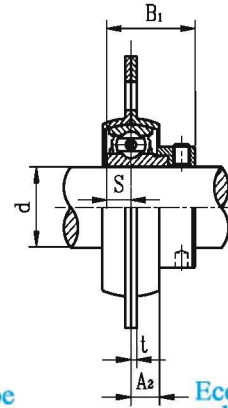

**SAPFT2**  
Eccentric locking collar type

Unit No.	Shaft Dia.		Dimensions(mm).								Bolt Size		Bearing No.	Housing No.	Mass (kg)
	d		L	P	A <sub>2</sub>	t	N	W	S	B					
	(in.)	(mm)													
SBPFT201		12													0.20
201-8	1/2	15													0.19
202	5/8	17	82	64	7	2	7.5	29	6	22	1/4	M6	PFT203		0.18
202-10															
203	11/16														
203-11															
SBPFT204-12	3/4	20	91	71	8	2	9	33	7	25	5/16	M8	SB204-12	PFT204	0.24
204															
SBPFT205-14	7/8														
205-15	15/16	25	95	76	9	2	9	35	7.5	27	5/16	M8	SB205-14	PFT205	0.32
205															
205-16	1														
SBPFT206-18	1-1/8	30	113	90	9	2.5	10.5	38	8	30	3/8	M10	SB206-18	PFT206	0.43
206															
206-19	1-3/16														
206-20	1-1/4														
SBPFT207-20	1-1/4														
207-21	1-5/16	35	122	100	10	2.5	10.5	45	8.5	32	3/8	M10	SB207-20	PFT207	0.62
207-22	1-3/8														
207															
207-23	1-7/16														

Unit No.	Shaft Dia.		Dimensions(mm).								Bolt Size		Bearing No.	Housing No.	Mass (kg)
	d		L	P	A <sub>2</sub>	t	N	W	S	B <sub>1</sub>					
	(in.)	(mm)													
SAPFT201		12													0.22
201-8	1/2	15													0.21
202	5/8	17	82	64	7	2	7.5	29	6.5	28.6	1/4	M6	PFT203		0.19
202-10															
203	11/16														
203-11															
SAPFT204-12	3/4	20	91	71	8	2	9	33	7.5	30.9	5/16	M8	SA204-12	PFT204	0.27
204															
SAPFT205-14	7/8														
205-15	15/16	25	95	76	9	2	9	35	7.5	30.9	5/16	M8	SA205-14	PFT205	0.34
205															
205-16	1														
SAPFT206-18	1-1/8	30	113	90	9	2.5	10.5	38	9	35.7	3/8	M10	SA206-18	PFT206	0.48
206															
206-19	1-3/16														
206-20	1-1/4														
SAPFT207-20	1-1/4														
207-21	1-5/16	35	122	100	10	2.5	10.5	45	9.5	38.9	3/8	M10	SA207-20	PFT207	0.68
207-22	1-3/8														
207															
207-23	1-7/16														



# TAKE-UP UNITS

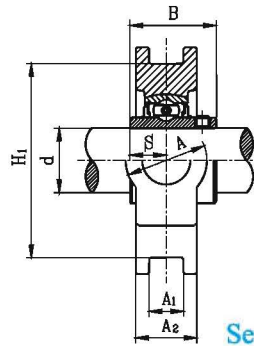
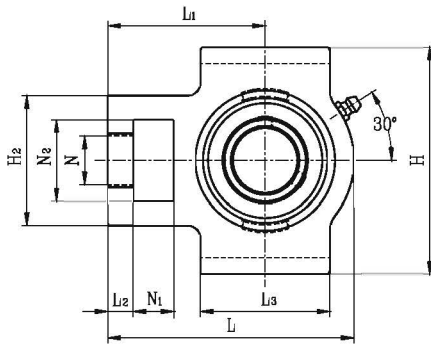

**UCT2**  
Setscrew type

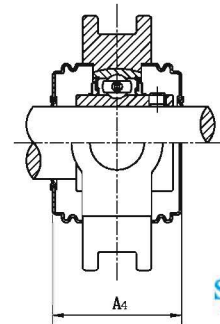

**S-UCT200E1**  
**SM-UCT200E1**  
With end cover

Unit No.	Shaft Dia.		Dimensions(mm).																Bearing No.	Housing No.	Mass (kg)
	d		N1	L2	H2	N2	N	L3	A1	H1	H	L	A	A2	L1	B	S	A4			
	(in.)	(mm)																			
UCT201S 201-8S 202S 202-10S 203S 203-11S	1/2 5/8 11/16	12 15 17	15	9	46	31	18	46	12	70	82	88	30	21	58	27.4	11.5	--	UC201S 201-8S 202S 202-10S 203S 203-11S	T203	0.62 0.61 0.60
UCT201 201-8 202 202-10 203 203-11 204-12 204	1/2 5/8 11/16 3/4 20	12 15 17 20	16	10	51	32	19	51	12	76	89	94	32	21	61	31	12.7	45	UC201 201-8 202 202-10 203 203-11 204-12 204	T204	0.78 0.76 0.75 0.73
UCT205-14 205-15 205 205-16	7/8 15/16 1	25	16	10	51	32	19	51	12	76	89	97	32	24	62	34	14.3	48	UC205-14 205-15 205 205-16	T205	0.82
UCT206-18 206 206-19 206-20	1-1/8 1-3/16 1-1/4	30	16	10	56	37	22	57	12	89	102	113	37	28	70	38.1	15.9	52	UC206-18 206 206-19 206-20	T206	1.23
UCT207-20 207-21 207-22 207 207-23	1-1/4 1-5/16 1-3/8 1-7/16	35	16	13	64	37	22	64	12	89	102	129	37	30	78	42.9	17.5	59	UC207-20 207-21 207-22 207 207-23	T207	1.61
UCT208-24 208-25 208	1-1/2 1-9/16	40	19	16	83	49	29	83	16	102	114	144	49	33	88	49.2	19	68	UC208-24 208-25 208	T208	2.34
UCT209-26 209-27 209-28 209	1-5/8 1-11/16 1-3/4	45	19	16	83	49	29	83	16	102	117	144	49	35	87	49.2	19	70	UC209-26 209-27 209-28 209	T209	2.33
UCT210-30 210-31 210	1-7/8 1-15/16	50	19	16	83	49	29	86	16	102	117	149	49	37	90	51.6	19	75	UC210-30 210-31 210	T210	2.48
UCT211-32 211-34 211 211-35	2 2-1/8 2-3/16	55	25	19	102	64	35	95	22	130	146	171	64	38	106	55.6	22.2	78	UC211-32 211-34 211 211-35	T211	3.79
UCT212-36 212 212-38 212-39	2-1/4 2-3/8 2-7/16	60	32	19	102	64	35	102	22	130	146	194	64	42	119	65.1	25.4	91	UC212-36 212 212-38 212-39	T212	4.61
UCT213-40 213	2-1/2	65	32	21	111	70	41	121	26	151	167	224	70	44	137	65.1	25.4	98	UC213-40 213	T213	6.62
UCT214-44 214	2-3/4	70	32	21	111	70	41	121	26	151	167	224	70	46	137	74.6	30.2	--	UC214-44 214	T214	6.76
UCT215 215-48	3	75	32	21	111	70	41	121	26	151	167	232	70	48	140	77.8	33.3	--	UC215 215-48	T215	7.18
UCT216		80	32	21	111	70	41	121	26	165	184	235	70	51	140	82.6	33.3	--	UC216	T216	8.40
UCT217-52 217	3-1/4	85	38	29	124	73	48	157	30	173	198	260	73	54	162	85.7	34.1	--	UC217-52 217	T217	10.7
UCT218-56 218	3-1/2	90	40	30	130	80	48	140	30	190	215	275	80	55	170	96	39.7	--	UC218-56 218	T218	11.8



# TAKE-UP UNITS

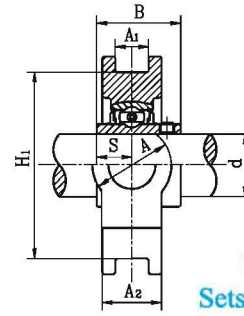
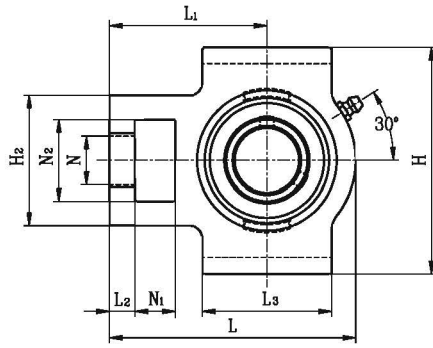

UCT3  
Setscrew type

Unit No.	Shaft Dia.		Dimensions(mm).														Bearing No.	Housing No.	Mass (kg)	
	d		N <sub>1</sub>	L <sub>2</sub>	H <sub>2</sub>	N <sub>2</sub>	N	L <sub>3</sub>	A <sub>1</sub>	H <sub>1</sub>	H	L	A	A <sub>2</sub>	L <sub>1</sub>	B				S
	(in.)	(mm)																		
UCT305-14 305-15 305 305-16	7/8 15/16	25	16	14	62	36	26	65	12	80	89	122	36	26	76	38	15	UC305-14 305-15 305 305-16	T305	1.25
UCT306-18 306 306-19	1-1/8 1-3/16	30	18	16	70	41	28	74	16	90	100	137	41	28	85	43	17	UC306-18 306 306-19	T306	1.79
UCT307-20 307-21 307-22 307	1-1/4 1-5/16 1-3/8	35	20	17	75	45	30	80	16	100	111	150	45	32	94	48	19	UC307-20 307-21 307-22 307	T307	2.34
UCT308-24 308-25 308	1-1/2 1-9/16	40	22	19	83	50	32	89	18	112	124	162	50	34	100	52	19	UC308-24 308-25 308	T308	2.99
UCT309-26 309-27 309-28 309	1-5/8 1-11/16 1-3/4	45	24	20	90	55	34	97	18	125	138	178	55	38	110	57	22	UC309-26 309-27 309-28 309	T309	3.93
UCT310-30 310-31 310	1-7/8 1-15/16	50	27	22	98	61	37	106	20	140	151	192	61	40	118	61	22	UC310-30 310-31 310	T310	5.03
UCT311-32 311-34 311 311-35	2 2-1/8 2-3/16	55	29	23	105	66	39	115	22	150	163	207	66	44	127	66	25	UC311-32 311-34 311 311-35	T311	6.19
UCT312-36 312 312-38 312-39	2-1/4 2-3/8 2-7/16	60	31	25	113	71	41	123	22	160	178	220	71	46	135	71	26	UC312-36 312 312-38 312-39	T312	7.48
UCT313-40 313	2-1/2	65	32	27	116	70	43	134	26	170	190	238	80	50	146	75	30	UC313-40 313	T313	9.48
UCT314-44 314	2-3/4	70	36	27	130	85	46	140	26	180	202	252	90	52	155	78	31	UC314-44 314	T314	11.0
UCT315 315-48	3	75	36	27	132	85	46	150	26	192	216	262	90	55	160	82	32	UC315 315-48	T315	12.7
UCT316		80	42	30	150	98	53	160	30	204	230	282	102	60	174	86	34	UC316	T316	16.1
UCT317-52 317	3-1/4	85	42	32	152	98	53	170	32	214	240	298	102	64	183	96	40	UC317-52 317	T317	18.6
UCT318-56 318	3-1/2	90	46	32	160	106	57	175	32	228	255	312	110	66	192	96	40	UC318-56 318	T318	21.3
UCT319 319-60	3-3/4	95	46	33	165	106	57	180	35	240	270	322	110	72	197	103	41	UC319 319-60	T319	24.7
UCT320 320-64	4	100	48	34	175	115	59	200	35	260	290	345	120	75	210	108	42	UC320 320-64	T320	30.2
UCT322		110	52	40	185	125	65	215	38	285	320	385	130	80	235	117	46	UC322	T322	40.2
UCT324		120	60	44	210	140	70	230	45	320	355	432	140	90	267	126	51	UC324	T324	55.0
UCT326		130	65	47	220	150	75	240	50	350	385	465	150	100	285	135	54	UC326	T326	69.0
UCT328		140	70	52	230	160	80	255	50	380	415	515	155	100	315	145	59	UC328	T328	83.7



# TAKE-UP UNITS

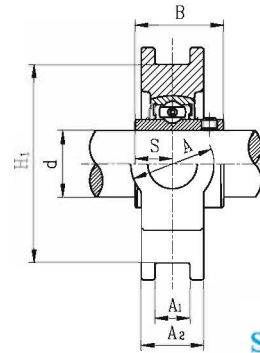
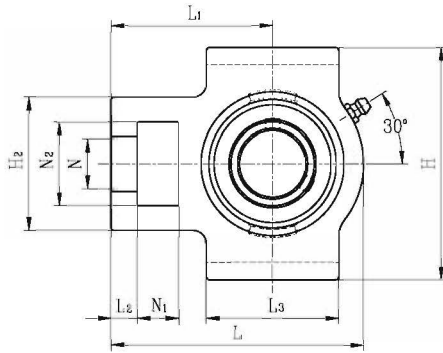

**UCST2**  
Setscrew type

Unit No.	Shaft Dia.		Dimensions(mm).															Bearing No.	Housing No.	Mass (kg)
	d (in.)	d (mm)	N1	L2	H2	N2	N	L3	A1	H1	H	L	A	A2	L1	B	S			
UCST201		12																UC201		0.77
201-8	1/2	15																201-8		0.75
202																		202		0.74
202-10	5/8	17	16	10	51	32	19	51	13.5	76	89	94	32	21	61	31	12.7	202-10	ST204	0.74
203																		203		0.72
203-11	11/16	20																203-11		0.72
204-12	3/4																	204-12		0.72
204																		204		0.72
UCST205-14	7/8																	UC205-14		
205-15	15/16	25	16	10	51	32	19	51	13.5	76	89	97	32	24	62	34	14.3	205-15	ST205	0.81
205																		205		
205-16	1																	205-16		
UCST206-18	1-1/8	30	16	10	56	37	22	57	13.5	89	102	113	37	28	70	38.1	15.9	UC206-18		
206																		206	ST206	1.23
206-19	1-3/16																	206-19		
206-20	1-1/4																	206-20		
UCST207-20	1-1/4																	UC207-20		
207-21	1-5/16	35	16	13	64	37	22	64	13.5	89	102	129	37	30	78	42.9	17.5	207-21	ST207	1.61
207-22	1-3/8																	207-22		
207																		207		
207-23	1-7/16																	207-23		
UCST208-24	1-1/2																	UC208-24		
208-25	1-9/16	40	19	16	83	49	29	83	17.5	102	114	144	49	33	88	49.2	19	208-25	ST208	2.28
208																		208		
UCST209-26	1-5/8																	UC209-26		
209-27	1-11/16	45	19	16	83	49	29	83	17.5	102	117	144	49	35	87	49.2	19	209-27	ST209	2.27
209-28	1-3/4																	209-28		
209																		209		
UCST210-30	1-7/8																	UC210-30		
210-31	1-15/16	50	19	16	83	49	29	86	17.5	102	117	149	49	37	90	51.6	19	210-31	ST210	2.40
210																		210		
UCST211-32	2																	UC211-32		
211-34	2-1/8	55	25	19	102	64	35	95	27	130	146	171	64	38	106	55.6	22.2	211-34	ST211	3.65
211																		211		
211-35	2-3/16																	211-35		
UCST212-36	2-1/4																	UC212-36		
212		60	32	19	102	64	35	102	27	130	146	194	64	42	119	65.1	25.4	212	ST212	4.59
212-38	2-3/8																	212-38		
212-39	2-7/16																	212-39		



# TAKE-UP UNITS

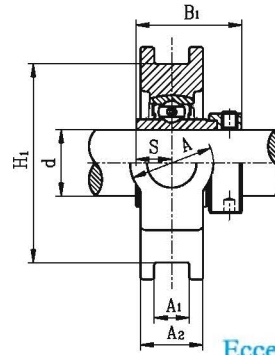
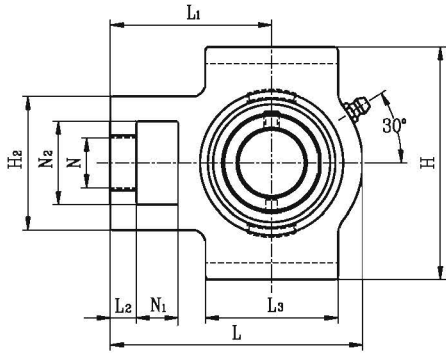

**NAT2**  
Eccentric locking collar type

Unit No.	Shaft Dia.		Dimensions(mm).														Bearing No.	Housing No.	Mass (kg)	
	d		N1	L2	H2	N2	N	L3	A1	H1	H	L	A	A2	L1	B1				S
	(in.)	(mm)																		
NAT201S 201-8S 202S 202-10S 203S 203-11S	1/2 5/8 11/16	12 15 17	15	9	46	31	18	46	12	70	82	88	30	21	58	37.3	13.9	NA 201S 201-8S 202S 202-10S 203S 203-11S	T203	0.73 0.72 0.70
NAT201 201-8 202 202-10 203 203-11 204-12 204	1/2 5/8 11/16 3/4 20	12 15 17 17 20	16	10	51	32	19	51	12	76	89	94	32	21	61	43.5	17	NA 201 201-8 202 202-10 203 203-11 204-12 204	T204	0.85 0.82 0.81 0.78
NAT205-14 205-15 205 205-16	7/8 15/16 1	25	16	10	51	32	19	51	12	76	89	97	32	24	62	44.3	17.4	NA 205-14 205-15 205 205-16	T205	0.87
NAT206-18 206 206-19 206-20	1-1/8 1-3/16 1-1/4	30	16	10	56	37	22	57	12	89	102	113	37	28	70	48.3	18.2	NA 206-18 206 206-19 206-20	T206	1.30
NAT207-20 207-21 207-22 207 207-23	1-1/4 1-5/16 1-3/8 1-7/16	35	16	13	64	37	22	64	12	89	102	129	37	30	78	51.1	18.8	NA 207-20 207-21 207-22 207 207-23	T207	1.68
NAT208-24 208-25 208	1-1/2 1-9/16	40	19	16	83	49	29	83	16	102	114	144	49	33	88	56.3	21.4	NA 208-24 208-25 208	T208	2.45
NAT209-26 209-27 209-28 209	1-5/8 1-11/16 1-3/4	45	19	16	83	49	29	83	16	102	117	144	49	35	87	56.3	21.4	NA 209-26 209-27 209-28 209	T209	2.45
NAT210-30 210-31 210	1-7/8 1-15/16	50	19	16	83	49	29	86	16	102	117	149	49	37	90	62.7	24.6	NA 210-30 210-31 210	T210	2.65
NAT211-32 211-34 211 211-35	2 2-1/8 2-3/16	55	25	19	102	64	35	95	22	130	146	171	64	38	106	71.3	27.7	NA 211-32 211-34 211 211-35	T211	4.04
NAT212-36 212 212-38 212-39	2-1/4 2-3/8 2-7/16	60	32	19	102	64	35	102	22	130	146	194	64	42	119	77.7	30.9	NA 212-36 212 212-38 212-39	T212	4.89
NAT213-40 213	2-1/2	65	32	21	111	70	41	121	26	151	167	224	70	44	137	85.7	34.1	NA 213-40 213	T213	7.01
NAT214-44 214	2-3/4	70	32	21	111	70	41	121	26	151	167	224	70	46	137	85.7	34.1	NA 214-44 214	T214	6.80
NAT215 215-48	3	75	32	21	111	70	41	121	26	151	167	232	70	48	140	92.1	37.3	NA 215 215-48	T215	7.64
NAT216		80	32	21	111	70	41	121	26	165	184	235	70	51	140	95.2	37.3	NA 216	T216	9.02
NAT217-52 217	3-1/4	85	38	29	124	73	48	157	30	173	198	260	73	54	162	73.2	23.4	NA 217-52 217	T217	10.9
NAT218-56 218	3-1/2	90	40	30	130	80	48	140	30	190	215	275	80	55	170	72.5	24.5	NA 218-56 218	T218	11.5



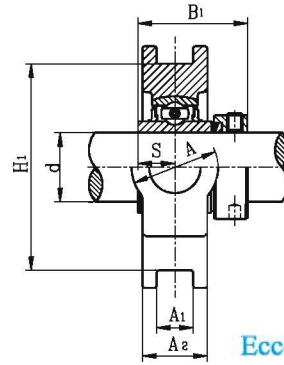
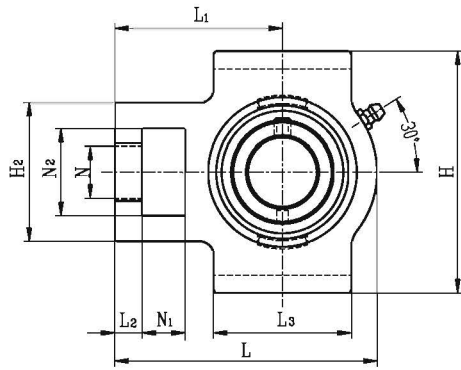

**NAT3**  
Eccentric locking collar type

Unit No.	Shaft Dia.		Dimensions(mm).														Bearing No.	Housing No.	Mass (kg)	
	d		N <sub>1</sub>	L <sub>2</sub>	H <sub>2</sub>	N <sub>2</sub>	N	L <sub>3</sub>	A <sub>1</sub>	H <sub>1</sub>	H	L	A	A <sub>2</sub>	L <sub>1</sub>	B <sub>1</sub>				S
	(in.)	(mm)																		
NAT305-14 305-15 305 305-16	7/8 15/16	25	16	14	62	36	26	65	12	80	89	122	36	26	76	46.8	16.7	NA305-14 305-15 305 305-16	T305	1.32
NAT306-18 306 306-19	1-1/8 1-3/16	30	18	16	70	41	28	74	16	90	100	137	41	28	85	50	17.5	NA306-18 306 306-19	T306	1.93
NAT307-20 307-21 307-22 307	1-1/4 1-5/16 1-3/8	35	20	17	75	45	30	80	16	100	111	150	45	32	94	51.6	18.3	NA307-20 307-21 307-22 307	T307	2.43
NAT308-24 308-25 308	1-1/2 1-9/16	40	22	19	83	50	32	89	18	112	124	162	50	34	100	57.1	19.8	NA308-24 308-25 308	T308	3.13
NAT309-26 309-27 309-28 309	1-5/8 1-11/16 1-3/4	45	24	20	90	55	34	97	18	125	138	178	55	38	110	58.7	19.8	NA309-26 309-27 309-28 309	T309	4.06
NAT310-30 310-31 310	1-7/8 1-15/16	50	27	22	98	61	37	106	20	140	151	192	61	40	118	66.6	24.6	NA310-30 310-31 310	T310	5.25
NAT311-32 311-34 311 311-35	2 2-1/8 2-3/16	55	29	23	105	66	39	115	22	150	163	207	66	44	127	73	27.8	NA311-32 311-34 311 311-35	T311	6.44
NAT312-36 312 312-38 312-39	2-1/4 2-3/8 2-7/16	60	31	25	113	71	41	123	22	160	178	220	71	46	135	79.4	29.5	NA312-36 312 312-38 312-39	T312	7.79
NAT313-40 313	2-1/2	65	32	27	116	70	43	134	26	170	190	238	80	50	146	85.7	32.5	NA313-40 313	T313	10.0
NAT314-44 314	2-3/4	70	36	27	130	85	46	140	26	180	202	252	90	52	155	92.1	34.15	NA314-44 314	T314	11.6
NAT315 315-48	3	75	36	27	132	85	46	150	26	192	216	262	90	55	160	100	37.3	NA315 315-48	T315	13.7
NAT316		80	42	30	150	98	53	160	30	204	230	282	102	60	174	106.4	40.5	NA316	T316	17.2
NAT317-52 317	3-1/4	85	42	32	152	98	53	170	32	214	240	298	102	64	183	109.5	42	NA317-52 317	T317	19.7
NAT318-56 318	3-1/2	90	46	32	160	106	57	175	32	228	255	312	110	66	192	115.9	43.6	NA318-56 318	T318	22.8
NAT319 319-60	3-3/4	95	46	33	165	106	57	180	35	240	270	322	110	72	197	122.3	46.8	NA319 319-60	T319	26.1
NAT320 320-64	4	100	48	34	175	115	59	200	35	260	290	345	120	75	210	128.6	50	NA320 320-64	T320	32.5

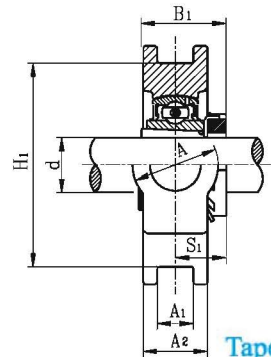
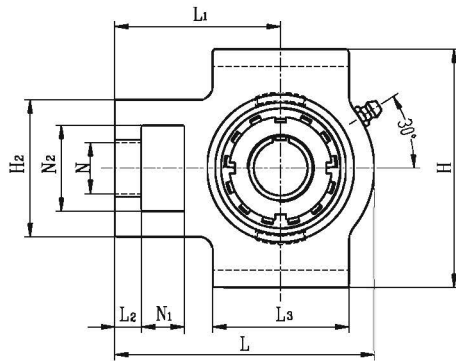

**UKT2+H**  
Tapered bore, adapter type

Unit No.	Shaft Dia.		Dimensions(mm).														Bearing No.	Housing No.	Adapter No.	Mass (kg)	
	d		N <sub>1</sub>	L <sub>2</sub>	H <sub>2</sub>	N <sub>2</sub>	N	L <sub>3</sub>	A <sub>1</sub>	H <sub>1</sub>	H	L	A	A <sub>2</sub>	L <sub>1</sub>	B <sub>1</sub>					S <sub>1</sub>
	(in.)	(mm)																			
UKT205+HE2305 205+H2305	3/4	20	16	10	51	32	19	51	12	76	89	97	32	24	62	35	18.5	UK205	T205	HE2305 H2305	0.86
UKT206+HS2306 206+HA2306 206+H2306 206+HE2306	7/8 15/16 1	25	16	10	56	37	22	57	12	89	102	113	37	28	70	38	20.5	UK206	T206	HS2306 HA2306 H2306 HE2306	1.30
UKT207+HS2307 207+H2307 207+HA2307	1-1/8 1-3/16	30	16	13	64	37	22	64	12	89	102	129	37	30	78	43	22.5	UK207	T207	HS2307 H2307 HA2307	1.66
UKT208+HE2308 208+HS2308 208+H2308	1-1/4 1-3/8	35	19	16	83	49	29	83	16	102	114	144	49	33	88	46	24.5	UK208	T208	HE2308 HS2308 H2308	2.40
UKT209+HA2309 209+HE2309 209+H2309	1-7/16 1-1/2	40	19	16	83	49	29	83	16	102	117	144	49	35	87	50	26	UK209	T209	HA2309 HE2309 H2309	2.44
UKT210+HS2310 210+HA2310 210+HE2310 210+H2310	1-5/8 1-11/16 1-3/4	45	19	16	83	49	29	86	16	102	117	149	49	37	90	55	27.5	UK210	T210	HS2310 HA2310 HE2310 H2310	2.66
UKT211+HS2311 211+HA2311 211+H2311 211+HE2311	1-7/8 1-15/16 2	50	25	19	102	64	35	95	22	130	146	171	64	38	106	59	28.5	UK211	T211	HS2311 HA2311 H2311 HE2311	3.95
UKT212+HS2312 212+H2312	2-1/8	55	32	19	102	64	35	102	22	130	146	194	64	42	119	62	31	UK212	T212	HS2312 H2312	4.71
UKT213+HA2313 213+HE2313 213+H2313 213+HS2313	2-3/16 2-1/4 2-3/8	60	32	21	111	70	41	121	26	151	167	224	70	44	137	65	32	UK213	T213	HA2313 HE2313 H2313 HS2313	6.70
UKT215+HA2315 215+HE2315 215+H2315	2-7/16 2-1/2	65	32	21	111	70	41	121	26	151	167	232	70	48	140	73	35.5	UC215	T215	HA2315 HE2315 A2315	7.55
UKT216+HA2316 216+HE2316 216+H2316	2-11/16 2-3/4	70	32	21	111	70	41	121	26	165	184	235	70	51	140	78	39	UC216	T216	HA2316 HE2316 H2316	8.87
UKT217+H2317		75	38	29	124	73	48	157	30	173	198	260	73	54	162	82	40	UC217	T217	H2317	11.1
UKT218+H2318		80	40	30	130	80	48	140	30	190	215	275	80	55	170	86	42	UK218	T218	H2318	12.2

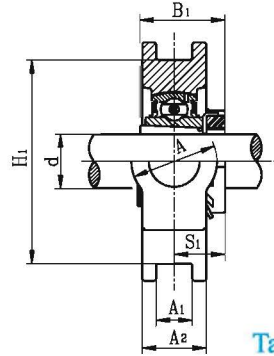
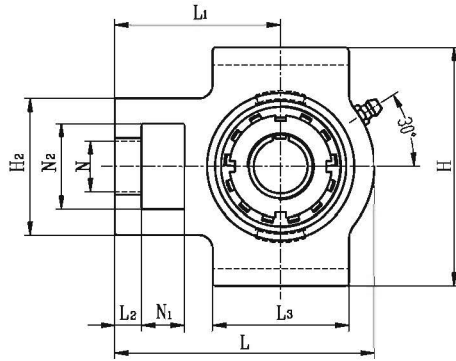

**UKT3+H**  
Tapered bore, adapter type

Unit No.	Shaft Dia.		Dimensions(mm).															Bearing No.	Housing No.	Adapter No.	Mass (kg)
	d		N <sub>1</sub>	L <sub>2</sub>	H <sub>2</sub>	N <sub>2</sub>	N	L <sub>3</sub>	A <sub>1</sub>	H <sub>1</sub>	H	L	A	A <sub>2</sub>	L <sub>1</sub>	B <sub>1</sub>	S <sub>1</sub>				
	(in.)	(mm)																			
UKT305+HE2305 305+H2305	3/4	20	16	14	62	36	26	65	12	80	89	122	36	26	76	35	21.5	UK305	T305	HE2305 H2305	1.30
UKT306+HS2306 306+HA2306 306+H2306 306+HE2306	7/8 15/16 1	25	18	16	70	41	28	74	16	90	100	137	41	28	85	38	23	UK306	T306	HS2306 HA2306 H2306 HE2306	1.84
UKT307+HS2307 307+H2307 307+HA2307	1-1/8 1-3/16	30	20	17	75	45	30	80	16	100	111	150	45	32	94	43	25.5	UK307	T307	HS2307 H2307 HA2307	2.38
UKT308+HE2308 308+HS2308 308+H2308	1-1/4 1-3/8	35	22	19	83	50	32	89	18	112	124	162	50	34	100	46	27.5	UK308	T308	HE2308 HS2308 H2308	3.04
UKT309+HA2309 309+HE2309 309+H2309	1-7/16 1-1/2	40	24	20	90	55	34	97	18	125	138	178	55	38	110	50	30	UK309	T309	HA2309 HE2309 H2309	4.07
UKT310+HS2310 310+HA2310 310+HE2310 310+H2310	1-5/8 1-11/16 1-3/4	45	27	22	98	61	37	106	20	140	151	192	61	40	118	55	32	UK310	T310	HS2310 HA2310 HE2310 H2310	5.07
UKT311+HS2311 311+HA2311 311+H2311 311+HE2311	1-7/8 1-15/16 2	50	29	23	105	66	39	115	22	150	163	207	66	44	127	59	33.5	UK311	T311	HS2311 HA2311 H2311 HE2311	6.21
UKT312+HS2312 312+H2312	2-1/8	55	31	25	113	71	41	123	22	160	178	220	71	46	135	62	36.5	UK312	T312	HS2312 H2312	7.48
UKT313+HA2313 313+HE2313 313+H2313 313+HS2313	2-3/16 2-1/4 2-3/8	60	32	27	116	70	43	134	26	170	190	238	80	50	146	65	38.5	UK313	T313	HA2313 HE2313 H2313 HS2313	9.44
UKT315+HA2315 315+HE2315 315+H2315	2-7/16 2-1/2	65	36	27	132	85	46	150	26	192	216	262	90	55	160	73	42.5	UC315	T315	HA2315 HE2315 H2315	13.0
UKT316+HA2316 316+HE2316 316+H2316	2-11/16 2-3/4	70	42	30	150	98	53	160	30	204	230	282	102	60	174	78	44.5	UC316	T316	HA2316 HE2316 H2316	16.3
UKT317+HA2317 317+H2317 317+HE2317	2-15/16 3	75	42	32	152	98	53	170	32	214	240	298	102	64	183	82	48	UC317	T317	HA2317 H2317 HE2317	18.6
UKT318+H2318		80	46	32	160	106	57	175	32	228	255	312	110	66	192	86	48	UK318	T318	H2318	21.5
UKT319+HE2319 319+H2319	3-1/4	85	46	33	165	106	57	180	35	240	270	322	110	72	197	90	52	UK319	T319	HE2319 H2319	24.5
UKT320+HE2320 320+H2320	3-1/2	90	48	34	175	115	59	200	35	260	290	345	120	75	210	97	54	UK320	T320	HE2320 H2320	30.2
UKT322		100	52	40	185	125	65	215	38	285	320	385	130	80	235	105	61	UK322	T322	H2322	40.2
UKT324		110	60	44	210	140	70	230	45	320	355	432	140	90	267	112	65.5	UK324	T324	H2324	54.6
UKT326		115	65	47	220	150	75	240	50	350	385	465	150	100	285	121	68	UK326	T326	H2326	68.8
UKT328		125	70	52	230	160	80	255	50	380	415	515	155	100	315	131	73	UK328	T328	H2328	83.5



# CYLINDRICAL CARTRIDGE UNITS

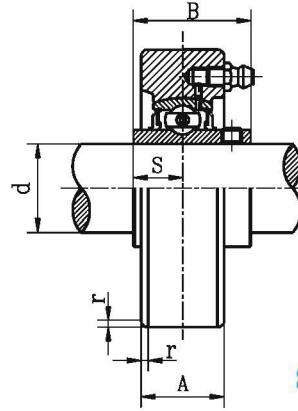
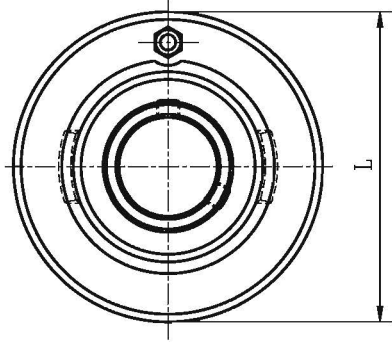

**UCC2**  
Setscrew type

Unit No.	Shaft Dia.		Dimensions(mm).					Bearing No.	Housing No.	Mass (kg)
	d		L	A	S	B	r			
(in.)	(mm)									
UCC201S 201-8S 202S 202-10S 203S 203-11S	1/2 5/8 11/16	12 15 17	67	20	11.5	27.4	1.5	UC 201S 201-8S 202S 202-10S 203S 203-11S	C203	0.43 0.42 0.41
UCC201 201-8 202 202-10 203 203-11 204-12 204	1/2 5/8 11/16 3/4 20	12 15 17 20	72	20	12.7	31	1.5	UC 201 201-8 202 202-10 203 203-11 204-12 204	C204	0.53 0.51 0.50 0.48
UCC205-14 205-15 205 205-16	7/8 15/16 1	25	80	22	14.3	34	1.5	UC 205-14 205-15 205 205-16	C205	0.64
UCC206-18 206 206-19 206-20	1-1/8 1-3/16 1-1/4	30	85	27	15.9	38.1	1.5	UC 206-18 206 206-19 206-20	C206	0.79
UCC207-20 207-21 207-22 207 207-23	1-1/4 1-5/16 1-3/8 1-7/16	35	90	28	17.5	42.9	1.5	UC 207-20 207-21 207-22 207 207-23	C207	0.92
UCC208-24 208-25 208	1-1/2 1-9/16	40	100	30	19	49.2	1.5	UC 208-24 208-25 208	C208	1.20
UCC209-26 209-27 209-28 209	1-5/8 1-11/16 1-3/4	45	110	31	19	49.2	2	UC 209-26 209-27 209-28 209	C209	1.47
UCC210-30 210-31 210 210-32	1-7/8 1-15/16 2	50	120	33	19	51.6	2	UC 210-30 210-31 210 210-32	C210	1.90
UCC211-32 211-34 211 211-35	2 2-1/8 2-3/16	55	125	35	22.2	55.6	2	UC 211-32 211-34 211 211-35	C211	2.12
UCC212-36 212 212-38 212-39	2-1/4 2-3/8 2-7/16	60	130	38	25.4	65.1	2	UC 212-36 212 212-38 212-39	C212	2.51
UCC213-40 213	2-1/2	65	140	40	25.4	65.1	2	UC 213-40 213	C213	2.90
UCC214-44 214	2-3/4	70	150	44	30.2	74.6	2.5	UC 214-44 214	C214	3.72
UCC215-47 215 UCC215-48	2-15/16 3	75	160	44	33.3	77.8	2.5	UC 215-47 215 UC 215-48	C215	4.39
UCC216		80	170	48	33.3	82.6	2.5	UC 216	C216	5.28



# CYLINDRICAL CARTRIDGE UNITS

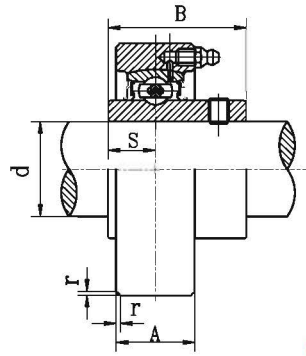
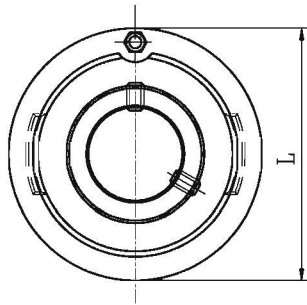

UCC3  
Setscrew type

Unit No.	Shaft Dia.		Dimensions(mm).					Bearing No.	Housing No.	Mass (kg)
	d		L	A	S	B	r			
	(in.)	(mm)								
UCC305-14 305-15 305 305-16	7/8 15/16 1	25	90	26	15	38	2.5	UC305-14 305-15 305 305-16	C305	0.96
UCC306-18 306 306-19	1-1/8 1-3/16	30	100	28	17	43	2.5	UC306-18 306 306-19	C306	1.36
UCC307-20 307-21 307-22 307	1-1/4 1-5/16 1-3/8	35	110	32	19	48	3	UC307-20 307-21 307-22 307	C307	1.72
UCC308-24 308-25 308	1-1/2 1-9/16	40	120	34	19	52	3	UC308-24 308-25 308	C308	2.17
UCC309-26 309-27 309-28 309	1-5/8 1-11/16 1-3/4	45	130	38	22	57	3.5	UC309-26 309-27 309-28 309	C309	2.69
UCC310-30 310-31 310	1-7/8 1-15/16	50	140	40	22	61	3.5	UC310-30 310-31 310	C310	3.32
UCC311-32 311-34 311 311-35	2 2-1/8 2-3/16	55	150	44	25	66	3.5	UC311-32 311-34 311 311-35	C311	4.01
UCC312-36 312 312-38 312-39	2-1/4 2-3/8 2-7/16	60	160	46	26	71	3.5	UC312-36 312 312-38 312-39	C312	4.73
UCC313-40 313	2-1/2	65	170	50	30	75	3.5	UC313-40 313	C313	5.62
UCC314-44 314	2-3/4	70	180	52	31	78	2.5	UC314-44 314	C314	6.55
UCC315 315-48	3	75	190	55	32	82	2.5	UC315 315-48	C315	7.92
UCC316		80	200	60	34	86	2.5	UC316	C316	8.93
UCC317-52 317	3-1/4	85	215	64	40	96	4	UC317-52 317	C317	11.2
UCC318-56 318	3-1/2	90	225	66	40	96	4	UC318-56 318	C318	12.4
UCC319 319-60	3-3/4	95	240	72	41	103	4	UC319 319-60	C319	15.6
UCC320 320-64	4	100	260	75	42	108	4	UC320 320-64	C320	19.3
UCC322		110	300	80	46	117	5	UC322	C322	29.0
UCC324		120	320	90	51	126	5	UC324	C324	36.0
UCC326		130	340	100	54	135	5	UC326	C326	43.0
UCC328		140	360	100	59	145	5	UC328	C328	49.7



# FLANGE BRACKET UNITS

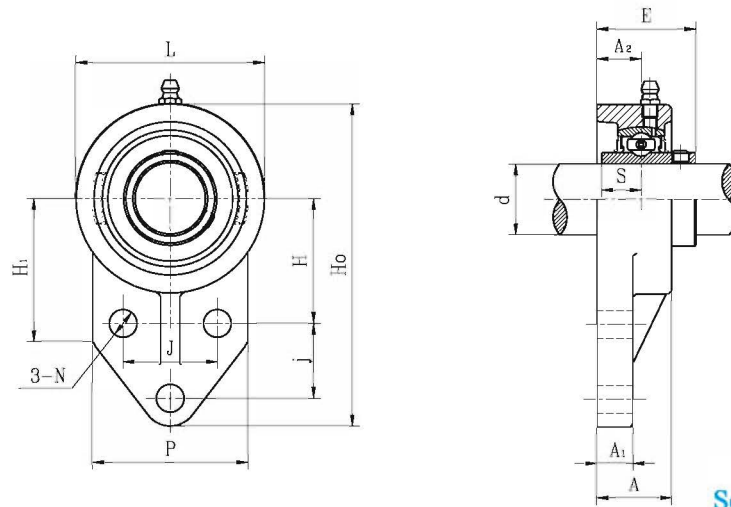

**UCFB2**  
Setscrew type

Unit No.	Shaft Dia.		Dimensions(mm).													Bolt Size	Bearing No.	Housing No.	Mass (kg)
	d		Ho	L	H1	P	H	j	J	A	A1	A2	N	E	S				
	(in.)	(mm)																	
UCFB201S 201-8S 202S 202-10S 203S 203-11S	1/2 5/8 11/16	12 15 17	104	55	50	49	40	27	30	23.5	10	14	10	29.9	11.5	M8	UC201S 201-8S 202S 202-10S 203S 203-11S	FB203	0.42 0.41 0.40
UCFB201 201-8 202 202-10 203 203-11 204-12 204	1/2 5/8 11/16 3/4 20	12 15 17 20	109	60	52	52	42	27	32	25.5	11	15	10	33.3	12.7	M8	UC201 201-8 202 202-10 203 203-11 204-12 204	FB204	0.52 0.50 0.49 0.47
UCFB205-14 205-15 205 205-16	7/8 15/16 1	25	116	68	52	56	45	27	34	27	13	16	10	35.7	14.3	M8	UC205-14 205-15 205 205-16	FB205	0.66
UCFB206-18 206 206-19 206-20	1-1/8 1-3/16 1-1/4	30	132	80	55	65	50	29	40	31	13	18	10	40.2	15.9	M8	UC206-18 206 206-19 206-20	FB206	0.95
UCFB207-20 207-21 207-22 207 207-23	1-1/4 1-5/16 1-3/8 1-7/16	35	144	90	62	70	55	32	46	33	14	19	10	44.4	17.5	M8	UC207-20 207-21 207-22 207 207-23	FB207	1.27
UCFB208-24 208-25 208	1-1/2 1-9/16	40	164	100	72	78	60	41	50	35	17	21	12	51.2	19	M10	UC208-24 208-25 208	FB208	1.71
UCFB209-26 209-27 209-28 209	1-5/8 1-11/16 1-3/4	45	175	108	76	80	65	43	54	38	16	22	12	52.2	19	M10	UC209-26 209-27 209-28 209	FB209	1.97
UCFB210-30 210-31 210 210-32	1-7/8 1-15/16 2	50	184	114	82	86	68	46	58	39	16	22	12	54.6	19	M10	UC210-30 210-31 210 210-32	FB210	2.26
UCFB211-32 211-34 211 211-35	2 2-1/8 2-3/16	55	207	128	86	90	78	50	62	42.5	18	25	14	58.4	22.2	M12	UC211-32 211-34 211 211-35	FB211	2.94
UCFB212-36 212 212-38 212-39	2-1/4 2-3/8 2-7/16	60	224	140	90	94	84	55	66	47.5	19	29	14	68.7	25.4	M12	UC212-36 212 212-38 212-39	FB212	4.04
UCFB213-40 213	2-1/2	65	244	152	95	102	92	60	70	49	20	30	14	69.7	25.4	M12	UC213-40 213	FB213	4.76

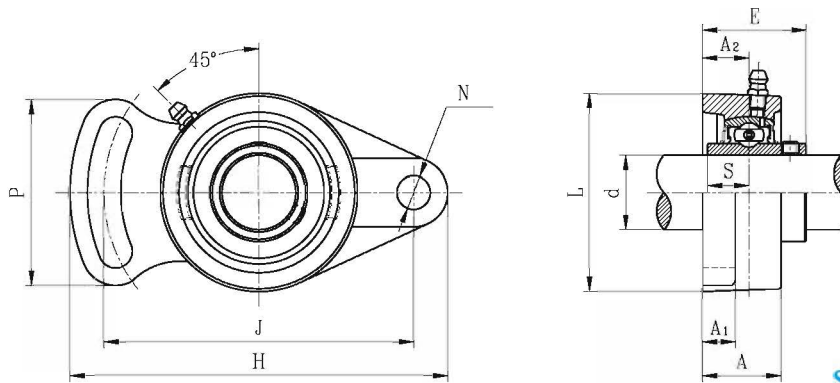

**UCFA2**  
Setscrew type

Unit No.	Shaft Dia.		Dimensions(mm).									Bolt Size	Bearing No.	Housing No.	Mass (kg)	
	d		H	J	L	P	A1	A2	A	N	E					S
	(in.)	(mm)														
UCFA201S 201-8S 202S 202-10S 203S 203-11S	1/2 5/8 11/16	12 15 17	95	75	57	47	9	13	22	10	28.9	11.5	M8	UC201S 201-8S 202S 202-10S 203S 203-11S	FA203	0.36 0.35 0.34
UCFA201 201-8 202 202-10 203 203-11 204-12 204	1/2 5/8 11/16 3/4	12 15 17 20	98	78	59	50	11	13.74	24	10	32.04	12.7	M8	UC201 201-8 202 202-10 203 203-11 204-12 204	FA204	0.43 0.41 0.40 0.38
UCFA205-14 205-15 205 205-16	7/8 15/16 1	25	122	96	70	64	13	16	27	12	35.7	14.3	M10	UC205-14 205-15 205 205-16	FA205	0.65
UCFA206-18 206 206-19 206-20	1-1/8 1-3/16 1-1/4	30	141	115	80	68	14	18	30.5	12	40.2	15.9	M10	UC206-18 206 206-19 206-20	FA206	0.96
UCFA207-20 207-21 207-22 207 207-23	1-1/4 1-5/16 1-3/8 1-7/16	35	155	128	92	75	15	19	33	13	44.4	17.5	M12	UC207-20 207-21 207-22 207 207-23	FA207	1.27
UCFA208-24 208-25 208	1-1/2 1-9/16	40	171	144	105	84	14	21	38	13	51.2	19	M12	UC208-24 208-25 208	FA208	1.80
UCFA209-26 209-27 209-28 209	1-5/8 1-11/16 1-3/4	45	178	146	108	88	16	22	38	16	52.2	19	M14	UC209-26 209-27 209-28 209	FA209	1.91
UCFA210-30 210-31 210 210-32	1-7/8 1-15/16 2	50	188	155	114	92	16	22	39	16	54.6	19	M14	UC210-30 210-31 210 210-32	FA210	2.09
UCFA211-32 211-34 211 211-35	2 2-1/8 2-3/16	55	216	182	128	102	18	25	42.5	16	58.4	22.2	M14	UC211-32 211-34 211 211-35	FA211	2.98
UCFA212-36 212 212-38 212-39	2-1/4 2-3/8 2-7/16	60	238	202	140	122	19	29	47.5	18	68.7	25.4	M16	UC212-36 212 212-38 212-39	FA212	4.14
UCFA213-40 213	2-1/2	65	248	210	152	126	20	30	49	18	69.7	25.4	M16	UC213-40 213	FA213	4.82

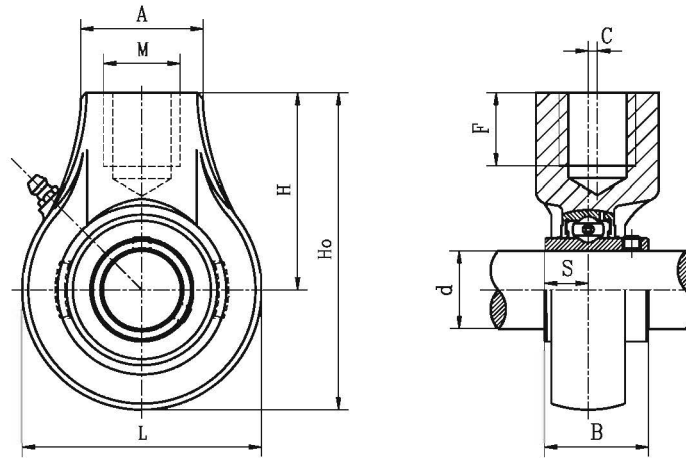

**UCHA2**  
Setscrew type

Unit No.	Shaft Dia.		Dimensions(mm).									Bearing No.	Housing No.	Mass (kg)
	d		Ho	L	C	H	A	F	M	B	S			
	(in.)	(mm)												
UCHA201S 201-8S 202S 202-10S 203S 203-11S	1/2 5/8 11/16	12 15 17	88.5	57	0	60	38	19	G3/4	27.4	11.5	UC 201S 201-8S 202S 202-10S 203S 203-11S	HA203	0.47 0.46 0.45
UCHA201 201-8 202 202-10 203 203-11 204-12 204	1/2 5/8 11/16 3/4	12 15 17 20	96	64	0	64	40	19	G3/4	31	12.7	UC 201 201-8 202 202-10 203 203-11 204-12 204	HA204	0.69 0.67 0.66 0.64
UCHA205-14 205-15 205 205-16	7/8 15/16 1	25	103	78	0	64	40	19	G3/4	34	14.3	UC205-14 205-15 205 205-16	HA205	0.81
UCHA206-18 206 206-19 206-20	1-1/8 1-3/16 1-1/4	30	103	78	0	64	40	19	G3/4	38.1	15.9	UC206-18 206 206-19 206-20	HA206	0.79
UCHA207-20 207-21 207-22 207 207-23	1-1/4 1-5/16 1-3/8 1-7/16	35	116	92	0	70	40	19	G3/4	42.9	17.5	UC207-20 207-21 207-22 207 207-23	HA207	1.16
UCHA208-24 208-25 208	1-1/2 1-9/16	40	121	96	2	73	40	19	G3/4	49.2	19	UC208-24 208-25 208	HA208	1.26
UCHA209-26 209-27 209-28 209	1-5/8 1-11/16 1-3/4	45	136	108	5	82	48	21	G1	49.2	19	UC209-26 209-27 209-28 209	HA209	1.74
UCHA210-30 210-31 210 210-32	1-7/8 1-15/16 2	50	140.5	115	5	83	48	21	G1	51.6	19	UC210-30 210-31 210 210-32	HA210	1.89
UCHA211-32 211-34 211 211-35	2 2-1/8 2-3/16	55	150	126	7	87	60	24	G1-1/4	55.6	22.2	UC211-32 211-34 211 211-35	HA211	2.52
UCHA212-36 212 212-38 212-39	2-1/4 2-3/8 2-7/16	60	173	142	9	102	60	28	G1-1/4	65.1	25.4	UC212-36 212 212-38 212-39	HA212	3.54
UCHA213-40 213	2-1/2	65	200	166	9.5	117	70	32	G1-1/2	65.1	25.4	UC213-40 213	HA213	5.33
UCHA214-44 214	2-3/4	70	200	166	9.5	117	70	32	G1-1/2	74.6	30.2	UC214-44 214	HA214	5.46
UCHA215-47 215 215-48	2-15/16 3	75	200	166	9.5	117	70	32	G1-1/2	77.8	33.2	UC215-47 215 215-48	HA215	5.33





# PRESSED HOUSING AGRICULTURAL DISK BEARINGS

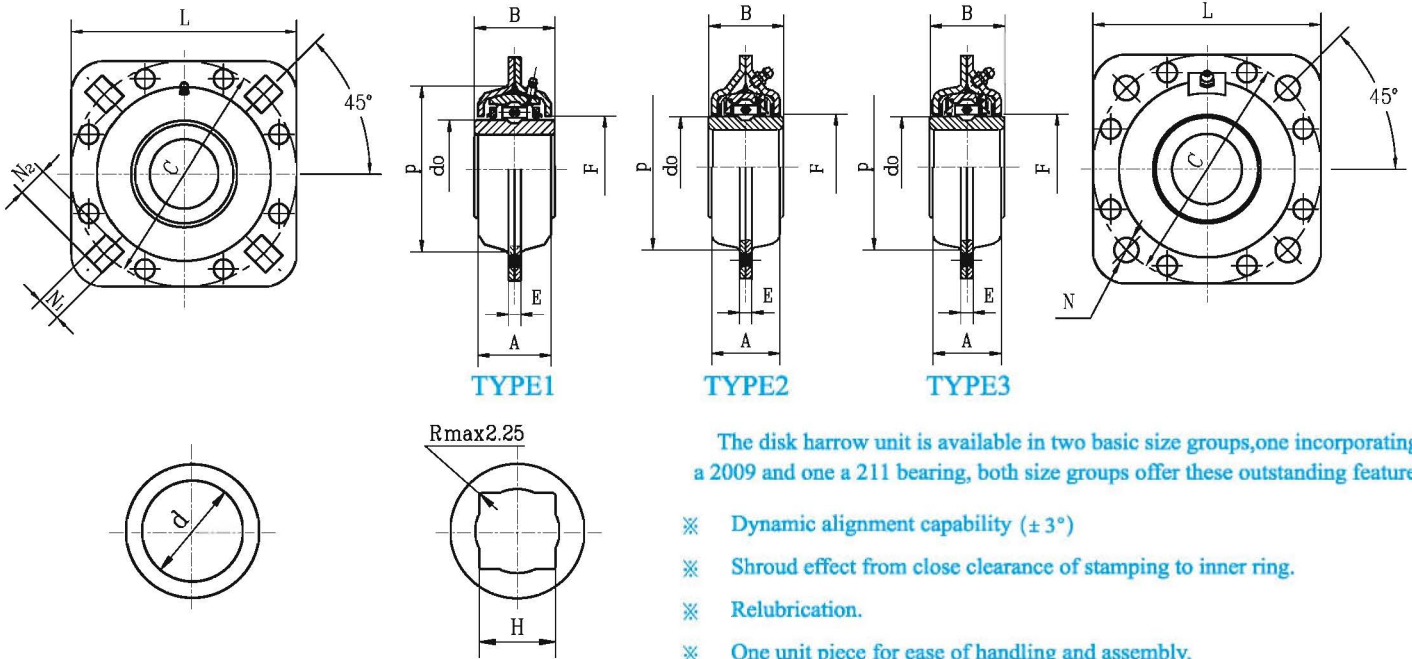

ROUND BORE(RD)

SQUARE BORE(SQ)

The disk harrow unit is available in two basic size groups, one incorporating a 209 and one a 211 bearing, both size groups offer these outstanding features.

- ※ Dynamic alignment capability ( $\pm 3^\circ$ )
- ※ Shroud effect from close clearance of stamping to inner ring.
- ※ Relubrication.
- ※ One unit piece for ease of handling and assembly.
- ※ Fitting flange mates with outer ring milled recess, preventing possibility of outer ring circumferential movement.

209 Series

Unit No.	TYPE	Bearing Bore Size (mm)		Dimensions(mm).									Basic Dynamic Load Rating (N).	Basic Static Load Rating (N).										
		H (SQ)	d (RD)	L	P	B	A	F	do	E	C	N(N1×N2)												
ST491A	1	--	45	127	98	42.8	42	60	57.547	7	127	Φ 13.5	31850	17500										
ST491A-I	2	--					37																	
ST491A-II	3	--					42																	
DHU45R-209	1	--	38.86				127								98	42.8	42	60	57.547	7	127	13.5×16.7	31850	17500
ST491B	1	--															37					Φ 13.5		
ST491B-I	2	--															42					13.5×16.7		
ST491B-II	3	--	37																					
ST209-1 1/8	1	--	42																					
ST209-1 1/8-I	2	29.972	--														127					98		
ST209-1 1/8-II	3	--	37																					

211 Series

Unit No.	TYPE	Bearing Bore Size (mm)		Dimensions(mm).									Basic Dynamic Load Rating (N).	Basic Static Load Rating (N).								
		H (SQ)	d (RD)	L	P	B	A	F	do	E	C	N(N1×N2)										
DHU55R-211	1	--	55	139.7	113.5	55.5	46.4	73	69	9	139.7	Φ 13.5	43550	25000								
DHU55R-211-I	2	--					51	42							71	8						
ST211-1 3/4	1	--	45.212				55.5	46.4							73	69	9	139.7	13.5×15.1			
ST211-2 3/16	1	--	55.575																	42	71	8
ST211-2 3/16-I	2	--	42																	71	8	
DHU40S-211	1	40.878	--				139.7	113.5							55.5	46.4	73	69	9	139.7	13.5×15.1	43550
FD211-1 1/2	2	38.89	--	51	42	71			8													



# BALL BEARING INSERTS

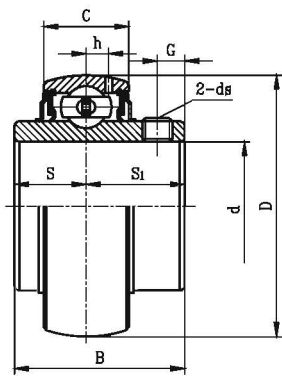

**UC2**  
Setescrew type

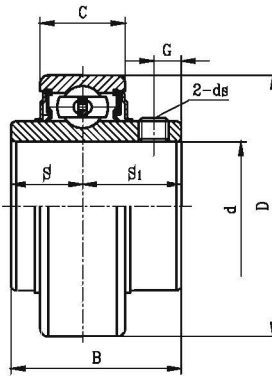

**RB2**  
Cylindrical O.D.

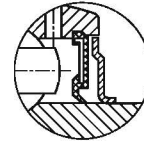

Dual seals

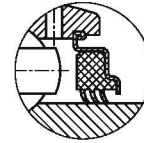

Tripple-lip seal  
(+Suffix-R3)

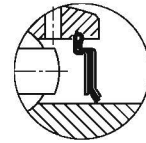

F seal  
(+Suffix-F)

Unit No.	Shaft Dia.		Dimensions(mm)/(in.)								Basic load rating (N)		Mass(kg)	
	d		D	B	C	S	S <sub>1</sub>	G	h	d <sub>s</sub>	Dynamic C <sub>r</sub>	Static C <sub>or</sub>	UC	RB
	(in.)	(mm)												
UC201S RB201-8S 202S 202-10S 203S 203-11S	1/2 5/8 11/16	12 15 17	40 1.5748	27.4 1.0787	14 0.5512	11.5 0.4528	15.9 0.6260	4.2 0.1654	3.5 0.1378	M5X0.8 10 #-32UNF	9550	4780	0.12 0.12 0.11 0.11 0.10 0.10	--
UC201 RB201-8 202 202-10 203 203-11 204-12 204	1/2 5/8 11/16 3/4 20	12 15 17 20	47 1.8504	31 1.2205	16 0.6299	12.7 0.5000	18.3 0.7205	4.7 0.1850	4.4 0.1732	M6X1 1/4-28UNF	12800	6650	0.21 0.20 0.21 0.19 0.20 0.19 0.18 0.19 0.17 0.18 0.16	0.22 0.21 0.20 0.20 0.19 0.19 0.18 0.17 0.18 0.17
UC205-14 RB205-15 205 205-16	7/8 15/16 1	25	52 2.0472	34 1.3386	17 0.6693	14.3 0.5630	19.7 0.7756	5.5 0.2165	4.3 0.1693	M6X1 1/4-28UNF	14000	7880	0.23 0.21 0.20 0.19	0.24 0.22 0.21 0.20
UC206-18 RB206 206-19 206-20	1-1/8 1-3/16 1-1/4	30	62 2.4409	38.1 1.5000	19 0.7480	15.9 0.6260	22.2 0.8740	5.5 0.2165	5 0.1969	M6X1 1/4-28UNF	19500	11200	0.33 0.31 0.31 0.29	0.34 0.32 0.32 0.30
UC207-20 RB207-21 207-22 207 207-23	1-1/4 1-5/16 1-3/8 207 1-7/16	35	72 2.8346	42.9 1.6890	20 0.7874	17.5 0.6890	25.4 1.0000	6.5 0.2559	5.8 0.2283	M8X1 5/16-24UNF	25700	15200	0.53 0.50 0.48 0.48 0.45	0.55 0.52 0.50 0.50 0.47
UC208-24 RB208-25 208	1-1/2 1-9/16	40	80 3.1496	49.2 1.9370	21 0.8268	19 0.7480	30.2 1.1890	8 0.3150	6.3 0.2480	M8X1 5/16-24UNF	29600	18200	0.68 0.65 0.63	0.70 0.67 0.65
UC209-26 RB209-27 209-28 209	1-5/8 1-11/16 1-3/4	45	85 3.3465	49.2 1.9370	22 0.8661	19 0.7480	30.2 1.1890	8 0.3150	6.8 0.2677	M8X1 5/16-24UNF	31850	20800	0.77 0.74 0.69 0.68	0.79 0.76 0.71 0.70
UC210-30 RB210-31 210 210-32	1-7/8 1-15/16 2	50	90 3.5433	51.6 2.0315	23 0.9055	19 0.7480	32.6 1.2835	9 0.3543	6.5 0.2559	M10X1.25 3/8-24UNF	35100	23200	0.82 0.79 0.75 0.72	0.85 0.82 0.78 0.75
UC211-32 RB211-34 211 211-35	2 2-1/8 2-3/16	55	100 3.9370	55.6 2.1890	25 0.9843	22.2 0.8740	33.4 1.3150	9 0.3543	7.2 0.2835	M10X1.25 3/8-24UNF	43550	29200	1.19 1.08 1.04 1.02	1.22 1.11 1.07 1.05
UC212-36 RB212 212-38 212-39	2-1/4 2-3/8 2-7/16	60	110 4.3307	65.1 2.5630	27 1.0630	25.4 1.0000	39.7 1.5630	10.5 0.4134	8.2 0.3228	M10X1.25 3/8-24UNF	47800	32800	1.54 1.41 1.39 1.32	1.58 1.45 1.43 1.36
UC213-40 213	2-1/2	65	120 4.7244	65.1 2.5630	28 1.1024	25.4 1.0000	39.7 1.5630	12 0.4724	8 0.3150	M12X1.25 3/8-24UNF	57200	40000	1.84 1.76	---
UC214-44 214	2-3/4	70	125 4.9213	74.6 2.9370	30 1.1811	30.2 1.1890	44.4 1.7480	12 0.4724	9 0.3543	M12X1.25 7/16-20UNF	60800	45000	2.01 2.00	---
UC215-47 215 215-48	2-15/16 3	75	130 5.1181	77.8 3.0630	30 1.1811	33.3 1.3110	44.5 1.7520	12 0.4724	9 0.3543	M12X1.25 7/16-20UNF	66000	49500	2.22 2.20 2.11	---
UC216		80	140 5.5118	82.6 3.2520	33 1.2992	33.3 1.3110	49.3 1.9410	14 0.5512	10.3 0.4055	M12X1.25 7/16-20UNF	71500	54200	2.73	---
UC217-52 217	3-1/4	85	150 5.9055	85.7 3.3740	35 1.3780	34.1 1.3425	51.6 2.0315	14 0.5512	11 0.4331	M12X1.25 7/16-20UNF	83200	63800	3.58 3.39	---
UC218-56 218	3-1/2	90	160 6.2992	96 3.7795	37 1.4567	39.7 1.5630	56.3 2.2165	14 0.5512	12 0.4724	M12X1.25 1/2-20UNF	95900	71500	4.23 4.11	---
UC220 220-64	4	100	180 7.0866	108 4.2520	40 1.5748	42 1.6535	66 2.5984	16 0.6299	12.1 0.4764	M16X1.5 5/8-18UNF	122000	92800	6.11 5.90	---



# BALL BEARING INSERTS

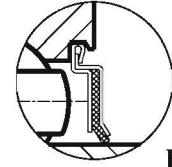
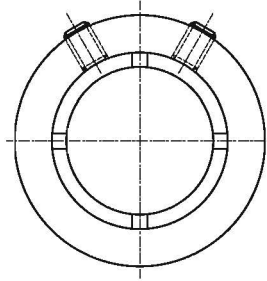
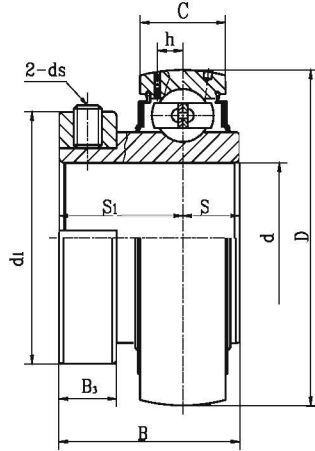

F seal

## UC2T Centric locking collar type

Unit No.	Shaft Dia.		Dimensions(mm)/(in.)									Basic load rating (N)		Mass (kg)
	d (in.)	d (mm)	D	B	C	S	S <sub>1</sub>	B <sub>3</sub>	h	d <sub>1</sub> (mm)	d <sub>s</sub>	Dynamic C <sub>r</sub>	Static C <sub>or</sub>	
UC204-12T 204T	3/4	20	47 1.8504	31 1.2205	16 0.6299	12.7 0.5000	18.3 0.7205	8.0 0.3150	4.4 0.1732	34.9	M5X0.8 10#-32UNF	12800	6650	0.20
UC205-13T 205-14T 205-15T 205T 205-16T	13/16 7/8 15/16 1	25	52 2.0472	34 1.3386	17 0.6693	14.3 0.5630	19.7 0.7756	8.8 0.3465	4.3 0.1693	34.9 39.7 39.7 39.7	M6×1 1/4-28UNF	14000	7880	0.24
UC206-16T 206-17T 206-18T 206T 206-19T 206-20T	1 1-1/16 1-1/8 206T 1-3/16 1-1/4	30	62 2.4409	38.1 1.5000	19 0.7480	15.9 0.6260	22.2 0.8740	8.8 0.3465	5 0.1969	46.0 46.0 46.0 50.8 50.8 50.8	M6×1 1/4-28UNF	19500	11200	0.35
UC207-19T 207-20T 207-21T 207-22T 207T 207-23T	1-3/16 1-1/4 1-5/16 1-3/8 1-7/16	35	72 2.8346	42.9 1.6890	20 0.7874	17.5 0.6890	25.4 1.0000	11.2 0.4409	5.8 0.2283	50.8 50.8 57.2 57.2 57.2	M8X1 5/16-24UNF	25700	15200	0.55
UC208-23T 208-24T 208-25T 208T 208-26T	1-7/16 1-1/2 1-9/16 1-5/8	40	80 3.1496	49.2 1.9370	21 0.8268	19 0.7480	30.2 1.1890	11.2 0.4409	6.3 0.2480	63.5	M8X1 5/16-24UNF	29600	18200	0.72
UC209-24T 209-26T 209-27T 209-28T 209T 209-29T	1-1/2 1-5/8 1-11/16 1-3/4 1-13/16	45	85 3.3465	49.2 1.9370	22 0.8661	19 0.7480	30.2 1.1890	11.2 0.4409	6.8 0.2677	63.5 63.5 68.3 68.3 68.3 68.3	M8X1 5/16-24UNF	31850	20800	0.82
UC210-27T 210-28T 210-29T 210-30T 210-31T 210T 210-32T	1-11/16 1-3/4 1-13/16 1-7/8 1-15/16 2	50	90 3.5433	51.6 2.0315	23 0.9055	19 0.7480	32.6 1.2835	14.2 0.5591	6.5 0.2559	69.9 69.9 69.9 73.0 73.0 73.0 73.0	M10X1.25 3/8-24UNF	35100	23200	0.95
UC211-31T 211-32T 211-33T 211-34T 211T 211-35T 211-36T	1-15/16 2 2-1/16 2-1/8 2-3/16 2-1/4	55	100 3.9370	55.6 2.1890	25 0.9843	22.2 0.8740	33.4 1.3150	14.2 0.5591	7.2 0.2835	73.0 73.0 79.4 79.4 79.4 79.4 79.4	M10X1.25 3/8-24UNF	43550	29200	1.35
UC212-35T 212-36T 212-37T 212T 212-38T 212-39T	2-3/16 2-1/4 2-5/16 2-3/8 2-7/16	60	110 4.3307	65.1 2.5630	27 1.0630	25.4 1.0000	39.7 1.5630	14.2 0.5591	8.2 0.3228	79.4 79.4 85.7 85.7 85.7 85.7	M10X1.25 3/8-24UNF	47800	32800	1.72
UC214-40T 214-42T 214-43T 214T	2-1/2 2-5/8 2-11/16	70	125 4.9213	74.6 2.9370	30 1.1811	30.2 1.1890	44.4 1.7480	14.2 0.5591	9 0.3543	100	M10X1.25 3/8-24UNF	60800	45000	2.20
UC215-44T 215-45T 215-46T 215-47T 215T	2-3/4 2-13/16 2-7/8 2-15/16	75	130 5.1181	77.8 3.0630	30 1.1811	33.3 1.3110	44.5 1.7520	14.2 0.5591	9 0.3543	100.0 106.4 106.4 106.4 106.4	M10X1.25 3/8-24UNF	66000	49500	2.50



# BALL BEARING INSERTS

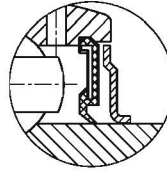
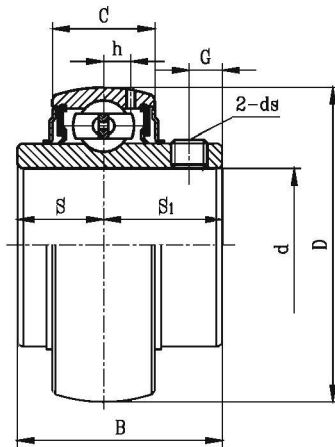

Dual seals

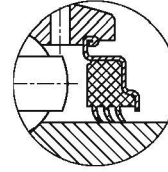

Tripple-lip seal  
(+Suffix-R3)

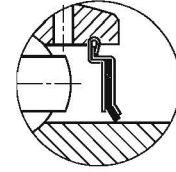

F seal  
(+Suffix-F)

## UCX Setscrew type

Unit No.	Shaft Dia.		Dimensions(mm)/(in.)								Basic load rating(N)		Mass (kg)
	d (in.)	d (mm)	D	B	C	S	S <sub>1</sub>	G	h	ds	Dynamic Cr	Static Cor	
UCX05-14 X05-15 X05 X05-16	7/8 15/16 1	25	62 2.4409	38.1 1.5000	19 0.7480	15.9 0.6260	22.2 0.8740	6 0.2362	5 0.1969	M6X1 1/4-28UNF	19500	11200	0.41 0.40 0.38 0.37
UCX06-18 X06 X06-19 X06-20	1-1/8 1-3/16 1-1/4	30	72 2.8346	42.9 1.6890	20 0.7874	17.5 0.6890	25.4 1.0000	6.5 0.2559	5.8 0.2283	M8X1 5/16-24UNF	25700	15200	0.57 0.55 0.55 0.52
UCX07-22 X07 X07-23	1-3/8 1-7/16	35	80 3.1496	49.2 1.9370	21 0.8268	19 0.7480	30.2 1.1890	8 0.3150	6.3 0.2480	M8X1 5/16-24UNF	29600	18200	0.75 0.75 0.72
UCX08-24 X08-25 X08	1-1/2 1-9/16	40	85 3.3465	49.2 1.9370	22 0.8661	19 0.7480	30.2 1.1890	8 0.3150	6.8 0.2677	M8X1 5/16-24UNF	31850	20800	0.84 0.80 0.79
UCX09-26 X09-27 X09-28 X09	1-5/8 1-11/16 1-3/4	45	90 3.5433	51.6 2.0315	23 0.9055	19 0.7480	32.6 1.2835	9 0.3543	6.5 0.2559	M10X1.25 3/8-24UNF	35100	23200	0.82 0.78 0.74 0.72
UCX10-30 X10-31 X10 X10-32	1-7/8 1-15/16 2	50	100 3.9370	55.6 2.1890	25 0.9843	22.2 0.8740	33.4 1.3150	9 0.3543	7.2 0.2835	M10X1.25 3/8-24UNF	43550	29200	1.30 1.24 1.22 1.19
UCX11-34 X11 X11-35 X11-36	2-1/8 2-3/16 2-1/4	55	110 4.3307	65.1 2.5630	27 1.0630	25.4 1.0000	39.7 1.5630	10.5 0.4134	8.2 0.3228	M10X1.25 3/8-24UNF	47800	32800	1.67 1.63 1.61 1.53
UCX12 X12-38 X12-39	2-3/8 2-7/16	60	120 4.7244	65.1 2.5630	28 1.1024	25.4 1.0000	39.7 1.5630	12 0.4724	8 0.3150	M12X1.25 3/8-24UNF	57200	40000	1.99 1.97 1.91
UCX13-40 X13	2-1/2	65	125 4.9213	74.6 2.9370	30 1.1811	30.2 1.1890	44.4 1.7480	12 0.4724	9 0.3543	M12X1.25 7/16-20UNF	60800	45000	2.39 2.31
UCX14-44 X14	2-3/4	70	130 5.1181	77.8 3.0630	30 1.1811	33.3 1.3110	44.5 1.7520	12 0.4724	9 0.3543	M12X1.25 7/16-20UNF	66000	49500	2.54 2.53
UCX15 X15-48	3	75	140 5.5118	82.6 3.2520	33 1.2992	33.3 1.3110	49.3 1.9410	14 0.5512	10.3 0.4055	M12X1.25 7/16-20UNF	71500	54200	3.11 3.03
UCX16		80	150 5.9055	85.7 3.3740	35 1.3780	34.1 1.3425	51.6 2.0315	14 0.5512	11 0.4331	M12X1.25 7/16-20UNF	83200	63800	3.83
UCX17-52 X17	3-1/4	85	160 6.2992	96 3.7795	37 1.4567	39.7 1.5630	56.3 2.2165	14 0.5512	12 0.4724	M12X1.25 7/16-20UNF	95900	71500	4.87 4.63
UCX18-56 X18	3-1/2	90	170 6.6929	104 4.0945	39 1.5354	42.9 1.6890	61.1 2.4055	14 0.5512	12.1 0.4764	M14X1.5 9/16-18UNF	109000	82800	5.72 5.59
UCX20 X20-64	4	100	190 7.4803	117.5 4.6260	44 1.7323	49.2 1.9370	68.3 2.6890	16 0.6299	13.7 0.5394	M16X1.5 5/8-18UNF	133000	105000	8.06 7.83



# BALL BEARING INSERTS

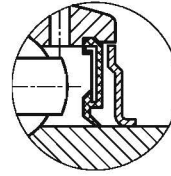
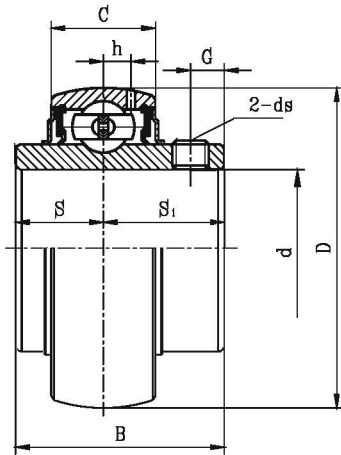

Dual seals

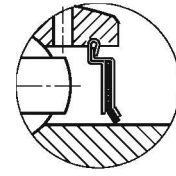

F seal  
(+Suffix-F)

UC3  
Setscrew type

Unit No.	Shaft Dia.		Dimensions(mm)/(in.)								Basic load rating(N)		Mass (kg)
	d		D	B	C	S	S <sub>1</sub>	G	h	ds	Dynamic C <sub>r</sub>	Static C <sub>or</sub>	
	(in.)	(mm)											
UC305-14 305-15 305 305-16	7/8 15/16 1	25	62 2.4409	38 1.4961	21 0.8268	15 0.5906	23 0.9055	6 0.2362	6.2 0.2441	M6X1 1/4-28UNF	22360	11500	0.37 0.35 0.34 0.34
UC306-18 306 306-19	1-1/8 1-3/16	30	72 2.8346	43 1.6929	24 0.9449	17 0.6693	26 1.0236	6 0.2362	6.5 0.2559	M6X1 1/4-28UNF	27000	15200	0.56 0.54 0.54
UC307-20 307-21 307-22 307	1-1/4 1-5/16 1-3/8	35	80 3.1496	48 1.8898	25 0.9843	19 0.7480	29 1.1417	8 0.3150	7.2 0.2835	M8X1 5/16-24UNF	33500	19200	0.73 0.70 0.67 0.67
UC308-24 308-25 308	1-1/2 1-9/16	40	90 3.5433	52 2.0472	28 1.1024	19 0.7480	33 1.2992	10 0.3937	8.5 0.3346	M10X1.25 3/8-24UNF	40560	24000	1.01 0.99 0.98
UC309-26 309-27 309-28 309	1-5/8 1-11/16 1-3/4	45	100 3.9370	57 2.2441	30 1.1811	22 0.8661	35 1.3780	10 0.3937	9 0.3543	M10X1.25 3/8-24UNF	53000	31800	1.335 1.30 1.26 1.24
UC310-30 310-31 310	1-7/8 1-15/16	50	110 4.3307	61 2.4016	32 1.2598	22 0.8661	39 1.5354	12 0.4724	9.9 0.3898	M12X1.25 7/16-20UNF	61750	37800	1.71 1.65 1.62
UC311-32 311-34 311 311-35	2 2-1/8 2-3/16	55	120 4.7244	66 2.5984	34 1.3386	25 0.9843	41 1.6142	12 0.4724	10.6 0.4173	M12X1.25 7/16-20UNF	71500	44800	2.22 2.10 2.05 2.02
UC312-36 312 312-38 312-39	2-1/4 2-3/8 2-7/16	60	130 5.1181	71 2.7953	36 1.4173	26 1.0236	45 1.7717	12 0.4724	11.3 0.4449	M12X1.25 7/16-20UNF	81600	51800	2.68 2.54 2.52 2.44
UC313-40 313	2-1/2	65	140 5.5118	75 2.9528	38 1.4961	30 1.1811	45 1.7717	12 0.4724	12.1 0.4764	M12X1.25 7/16-20UNF	93860	60500	3.16 3.07
UC314-44 314	2-3/4	70	150 5.9055	78 3.0709	40 1.5748	31 1.2205	47 1.8504	12 0.4724	12.8 0.5039	M12X1.25 7/16-20UNF	104260	68000	3.75 3.74
UC315 315-48	3	75	160 6.2992	82 3.2283	42 1.6535	32 1.2598	50 1.9685	14 0.5512	13.5 0.5315	M14X1.5 1/2-20UNF	113360	76800	4.45 4.37
UC316		80	170 6.6929	86 3.3858	44 1.7323	34 1.3386	52 2.0472	14 0.5512	14.5 0.5709	M14X1.5 1/2-20UNF	122850	86500	5.33
UC317-52 317	3-1/4	85	180 7.0866	96 3.7795	46 1.8110	40 1.5748	56 2.2047	16 0.6299	15.5 0.6102	M16X1.5 5/8-18UNF	132600	96500	6.66 6.42
UC318-56 318	3-1/2	90	190 7.4803	96 3.7795	48 1.8898	40 1.5748	56 2.2047	16 0.6299	16.5 0.6496	M16X1.5 5/8-18UNF	143000	108000	7.32 7.20
UC319 319-60	3-3/4	95	200 7.8740	103 4.0551	50 1.9685	41 1.6142	62 2.4409	18 0.7087	16.7 0.6574	M16X1.5 5/8-18UNF	156000	122000	8.70 8.67
UC320 320-64	4	100	215 8.4646	108 4.2520	54 2.2160	42 1.6535	66 2.5984	18 0.7087	19 0.7480	M18X1.5 5/8-18UNF	171600	140000	10.5 10.3
UC322		110	240 9.4488	117 4.6063	60 2.3622	46 1.8110	71 2.7953	18 0.7087	21 0.8268	M18X1.5	158000	178000	14.5
UC324		120	260 10.2362	126 4.9606	64 2.5197	51 2.0079	75 2.9528	18 0.7087	22 0.8661	M18X1.5	175000	208000	18.5
UC326		130	280 11.0236	135 5.3150	68 2.6772	54 2.1260	81 3.1890	20 0.7874	23 0.9055	M20X1.5	195000	242000	23.0
UC328		140	300 11.8110	145 5.7087	72 2.8346	59 2.3228	86 3.3858	20 0.7874	25 0.9843	M20X1.5	212000	272000	28.2

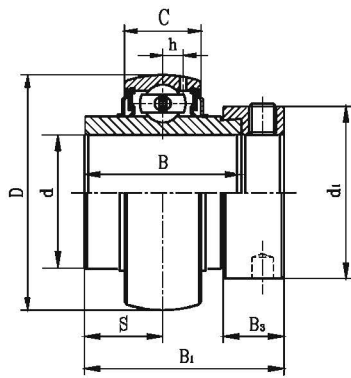

NA2

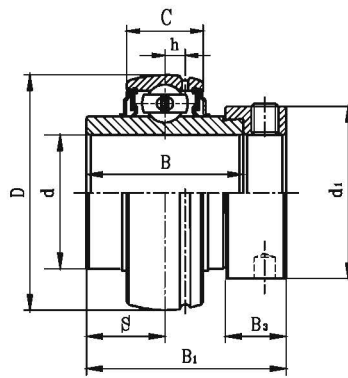

HC2

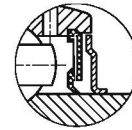

Dual seals

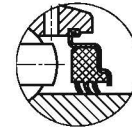

Triple-lip seal  
(+Suffix-R3)

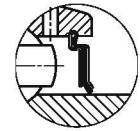

F seal  
(+Suffix-F)

Eccentric locking collar type

Unit No.	Shaft Dia.		Dimensions(mm)/(in.)								Eccentric collar	Basic load rating(N)		Mass (kg)
	d		D	C	B	S	B <sub>1</sub>	B <sub>3</sub>	h	d <sub>1</sub>		Dynamic Cr	Static Cor	
	(in.)	(mm)												
NA201S HC201-8S 202S 202-10S 203S 203-11S	1/2 5/8 11/16	12 15 17	40 1.5748	14 0.5512	27.8 1.0945	13.9 0.5472	37.3 1.4685	13.5 0.5315	3.5 0.1378	27.2 1.0709	A201S 201-8S 202S 202-10S 203S 203-11S	9550	4780	0.23 0.23 0.22 0.21 0.20 0.19
NA201 HC201-8 202 202-10 203 203-11 204-12 204	1/2 5/8 11/16 3/4	12 15 17 20	47 1.8540	16 0.6299	34 1.3386	17 0.6693	43.5 1.7126	13.5 0.5315	4.4 0.1732	32.4 1.2756	A201 201-8 202 202-10 203 203-11 204-12 204	12800	6650	0.28 0.27 0.25 0.25 0.24 0.24 0.22 0.21
NA205-14 HC205-15 205 205-16	7/8 15/16 1	25	52 2.0472	17 0.6693	34.8 1.3701	17.4 0.6850	44.3 1.7441	13.5 0.5315	4.3 0.1693	37.4 1.4724	A205-14 205-15 205 205-16	14000	7880	0.29 0.27 0.25 0.24
NA206-18 HC206 206-19 206-20	1-1/8 1-3/16 1-1/4	30	62 2.4409	19 0.7480	36.4 1.4331	18.2 0.7165	48.3 1.9016	15.9 0.6260	5 0.1969	44.1 1.7362	A206-18 206 206-19 206-20	19500	11200	0.40 0.38 0.38 0.35
NA207-20 HC207-21 207-22 207 207-23	1-1/4 1-5/16 1-3/8 1-7/16	35	72 2.8346	20 0.7874	37.6 1.4803	18.8 0.7402	51.1 2.0118	17.5 0.6890	5.8 0.2283	51.1 2.0118	A207-20 207-21 207-22 207 207-23	25700	15200	0.62 0.59 0.55 0.55 0.52
NA208-24 HC208-25 208	1-1/2 1-9/16	40	80 3.1496	21 0.8268	42.8 1.6850	21.4 0.8425	56.3 2.2165	18.3 0.7205	6.3 0.2480	58 2.2835	A208-24 208-25 208	29600	18200	0.79 0.75 0.74
NA209-26 HC209-27 209-28 209	1-5/8 1-11/16 1-3/4	45	85 3.3465	22 0.8661	42.8 1.6850	21.4 0.8425	56.3 2.2165	18.3 0.7205	6.8 0.2677	63.5 2.5000	A209-26 209-27 209-28 209	31850	20800	0.90 0.86 0.81 0.80
NA210-30 HC210-31 210	1-7/8 1-15/16	50	90 3.5433	23 0.9055	49.2 1.9370	24.6 0.9685	62.7 2.4685	18.3 0.7205	6.5 0.2559	67.2 2.6457	A210-30 210-31 210	35100	23200	1.01 0.95 0.92
NA211-32 HC211-34 211 211-35	2 2-1/8 2-3/16	55	100 3.9370	25 0.9843	55.4 2.1811	27.7 1.0906	71.3 2.8071	20.7 0.8150	7.2 0.2835	74.5 2.9331	A211-32 211-34 211 211-35	43550	29200	1.50 1.34 1.29 1.27
NA212-36 HC212 212-38 212-39	2-1/4 2-3/8 2-7/16	60	110 4.3307	27 1.0630	61.8 2.4331	30.9 1.2165	77.7 3.0591	22.3 0.8780	8.2 0.3228	82 3.2283	A212-36 212 212-38 212-39	47800	32800	1.85 1.69 1.67 1.58
NA213-40 HC213	2-1/2	65	120 4.7244	28 1.1024	68.2 2.6850	34.1 1.3425	85.7 3.3740	23.5 0.9252	8 0.3150	86 3.3858	A213-40 213	57200	40000	2.25 2.15
NA214-44 HC214	2-3/4	70	125 4.9213	30 1.1811	68.2 2.6850	34.1 1.3425	85.7 3.3740	23.5 0.9252	9 0.3543	96.8 3.8110	A214-44 214	60800	45000	2.42 2.04
NA215 HC215-48	3	75	130 5.1181	30 1.1811	74.6 2.9370	37.3 1.4685	92.1 3.6260	23.9 0.9409	9 0.3543	102 4.0160	A215 215-48	66000	49500	2.66 2.60
NA HC216		80	140 5.5118	33 1.2992	74.6 2.9370	37.3 1.4685	95.2 3.7480	27 1.0630	10.3 0.4055	110 4.3307	A216	71500	54200	3.35
NA217-52 HC217	3-1/4	85	150 5.9055	35 1.3780	53.2 2.0945	23.4 0.9213	73.2 2.8819	27 1.0630	11 0.4331	119 4.6850	A217-52 217	83200	63800	3.78 3.60
NA218-56 HC218	3-1/2	90	160 6.2992	37 1.4567	55 2.1654	24.5 0.9646	72.5 2.8543	24 0.9449	12 0.4724	120 4.7244	A218-56 218	95900	71500	3.86 3.77
NA HC 220		100	180 7.0866	40 1.5748	100 3.9370	50 1.9685	125.4 4.9370	31.8 1.2519	12.1 0.4763	139.7 5.500	A220	122000	92800	7.45

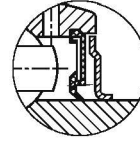
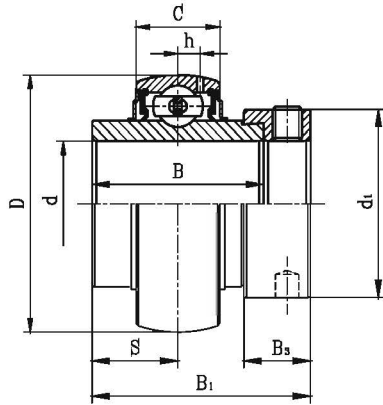

Dual seals

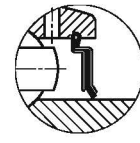

F seal  
(+Suffix-F)

### NA3 Eccentric locking collar type

Unit No.	Shaft Dia.		Dimensions(mm)/(in.)								Eccentric collar	Basic load rating(N)		Mass (kg)
	d		D	B	C	S	B <sub>1</sub>	B <sub>3</sub>	h	d <sub>1</sub>		Dynamic Cr	Static Cor	
	(in.)	(mm)												
NA305-14 305-15 305 305-16	7/8 15/16 1	25	62 2.4409	34.9 1.3740	21 0.8268	16.7 0.6575	46.8 1.8425	15.9 0.6260	6.2 0.2441	42.8 1.6850	A305-14 305-15 305 305-16	22360	11500	0.45 0.43 0.41 0.40
NA306-18 306 306-19	1-1/8 1-3/16	30	72 2.8346	36.5 1.4370	24 0.9449	17.5 0.6890	50 1.9685	17.5 0.6890	6.5 0.2559	50 1.9685	A306-18 306 306-19	27000	15200	0.71 0.68 0.68
NA307-20 307-21 307-22 307 307-23	1-1/4 1-5/16 1-3/8 1-7/16	35	80 3.1496	38.1 1.5000	25 0.9843	18.3 0.7205	51.6 2.0315	17.5 0.6890	7.2 0.2835	55 2.1654	A307-20 307-21 307-22 307 307-23	33500	19200	0.84 0.81 0.77 0.77 0.74
NA308-24 308-25 308	1-1/2 1-9/16	40	90 3.5433	41.3 1.6260	28 1.1024	19.8 0.7795	57.1 2.2480	20.6 0.8110	8.5 0.3346	63.5 2.5000	A308-24 308-25 308	40560	24000	1.17 1.13 1.12
NA309-26 309-27 309-28 309	1-5/8 1-11/16 1-3/4	45	100 3.9370	42.9 1.6890	30 1.1811	19.8 0.7795	58.7 2.3110	20.6 0.8110	9 0.3543	70 2.7559	A309-26 309-27 309-28 309	53000	31800	1.49 1.44 1.39 1.37
NA310-30 310-31 310	1-7/8 1-15/16	50	110 4.3307	49.2 1.9370	32 1.2598	24.6 0.9685	66.6 2.6220	22.2 0.8740	9.9 0.3898	76.2 3.0000	A310-30 310-31 310	61750	37800	1.93 1.87 1.84
NA311-32 311-34 311 311-35	2 2-1/8 2-3/16	55	120 4.7244	55.6 2.1890	34 1.3386	27.8 1.0945	73 2.8740	22.2 0.8740	10.6 0.4173	83 3.2677	A311-32 311-34 311 311-35	71500	44800	2.52 2.36 2.30 2.27
NA312-36 312 312-38 312-39	2-1/4 2-3/8 2-7/16	60	130 5.1181	61.9 2.4370	36 1.4173	30.95 1.2185	79.4 3.1260	23.9 0.9409	11.3 0.4449	89 3.5039	A312-36 312 312-38 312-39	81600	51800	3.01 2.85 2.83 2.74
NA313-40 313	2-1/2	65	140 5.5118	65.1 2.5630	38 1.4961	32.5 1.2795	85.7 3.3740	27 1.0630	12.1 0.4764	97 3.8189	A313-40 313	93860	60500	3.69 3.59
NA314-44 314	2-3/4	70	150 5.9055	68.3 2.6890	40 1.5748	34.15 1.3445	92.1 3.6260	30.2 1.1890	12.8 0.5039	102 4.0157	A314-44 314	104260	68000	4.42 4.40
NA315 315-48	3	75	160 6.2992	74.6 2.9370	42 1.6535	37.3 1.4685	100 3.9370	31.8 1.2520	13.5 0.5315	113 4.4488	A315 315-48	113360	76800	5.42 5.31
NA316		80	170 6.6929	81 3.1890	44 1.7323	40.5 1.5945	106.4 4.1890	31.8 1.2520	14.5 0.5709	119 4.6850	A316	122850	86500	6.45
NA317-52 317	3-1/4	85	180 7.0866	84.1 3.3110	46 1.8110	42 1.6535	109.5 4.3110	31.8 1.2520	15.5 0.6102	127 5.0000	A317-52 317	132600	96500	7.74 7.46
NA318-56 318	3-1/2	90	190 7.4803	87.3 3.4370	48 1.8898	43.6 1.7165	115.9 4.5630	36.5 1.4370	16.5 0.6496	133 5.2362	A318-56 318	143000	108000	8.76 8.61
NA319 319-60	3-3/4	95	200 7.8740	93.7 3.6890	50 1.9685	46.8 1.8425	122.3 4.8150	36.5 1.4370	16.7 0.6574	140 5.5118	A319 319-60	156000	122000	10.1 10.0
NA320 320-64	4	100	215 8.4646	100 3.9370	54 2.2160	50 1.9685	128.6 5.0630	36.5 1.4370	19 0.7480	146 5.7480	A320 320-64	171600	140000	12.9 12.6

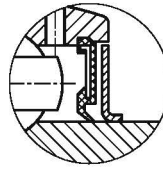
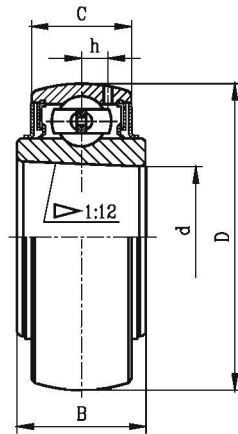

Dual seals

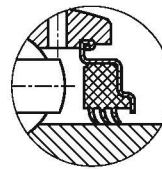

Tripple-lip seal  
(+Suffix-R3)

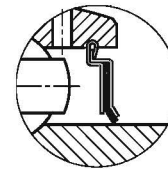

F seal  
(+Suffix-F)

## UK2 Tapered bore

Bearing No.	Dimensions(mm)/(in).					Basic load rating(N)		Mass (kg)
	d	D	B	C	h	Dynamic Cr	Static Cor	
UK205	25 0.9843	52 2.0472	21 0.8268	17 0.6693	4.3 0.1693	14000	7880	0.15
UK206	30 1.1811	62 2.4409	25 0.9843	19 0.7480	5 0.1969	19500	11200	0.25
UK207	35 1.3780	72 2.8346	27 1.0630	20 0.7874	5.8 0.2283	25700	15200	0.36
UK208	40 1.5748	80 3.1496	29 1.1417	21 0.8268	6.3 0.2480	29600	18200	0.47
UK209	45 1.7717	85 3.3465	30 1.1811	22 0.8661	6.8 0.2677	31850	20800	0.51
UK210	50 1.9685	90 3.5433	31 1.2205	23 0.9055	6.5 0.2559	35100	23200	0.57
UK211	55 2.1654	100 3.9370	33 1.2992	25 0.9843	7.2 0.2835	43550	29200	0.78
UK212	60 2.3622	110 4.3307	36 1.4173	27 1.0630	8.2 0.3228	47800	32800	1.03
UK213	65 2.5591	120 4.7244	36 1.4173	28 1.1024	8 0.3150	57200	40000	1.29
UK215	75 2.9528	130 5.1181	41 1.6142	30 1.1811	9 0.3543	66000	49500	1.52
UK216	80 3.1496	140 5.5118	44 1.7323	33 1.2992	10.3 0.4055	71500	54200	1.90
UK217	85 3.3465	150 5.9055	44 1.7323	35 1.3780	11 0.4331	83200	63800	2.33
UK218	90 3.5433	160 6.2992	48 1.8898	37 1.4567	12 0.4724	95900	71500	2.77





# BALL BEARING INSERTS

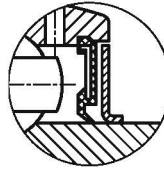
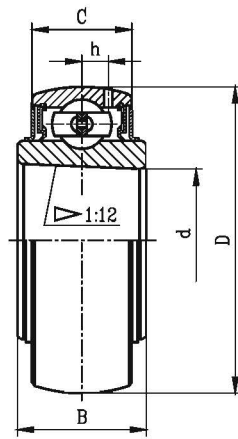

Dual seals

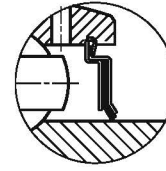

F seal  
(+Suffix-F)

UK3  
Tapered bore

Bearing No.	Dimensions(mm)/(in).					Basic load rating(N)		Mass (kg)
	d	D	B	C	h	Dynamic Cr	Static Cor	
UK305	25 0.9843	62 2.4409	27 1.0630	21 0.8268	6.2 0.2441	22360	11500	0.30
UK306	30 1.1811	72 2.8346	30 1.1811	24 0.9449	6.5 0.2559	27000	15200	0.46
UK307	35 1.3780	80 3.1496	33 1.2992	25 0.9843	7.2 0.2835	33500	19200	0.54
UK308	40 1.5748	90 3.5433	35 1.3780	28 1.1024	8.5 0.3346	40560	24000	0.81
UK309	45 1.7717	100 3.9370	38 1.4961	30 1.1811	9 0.3543	53000	31800	1.10
UK310	50 1.9685	110 4.3307	40 1.5748	32 1.2598	9.9 0.3898	61750	37800	1.30
UK311	55 2.1654	120 4.7244	43 1.6929	34 1.3386	10.6 0.4173	71500	44800	1.65
UK312	60 2.3622	130 5.1181	47 1.8504	36 1.4173	11.3 0.4449	81600	51800	2.06
UK313	65 2.5591	140 5.5118	49 1.9291	38 1.4961	12.1 0.4764	93860	60500	2.48
UK315	75 2.9528	160 6.2992	55 2.1654	42 1.6535	13.5 0.5315	113360	76800	3.70
UK316	80 3.1496	170 6.6929	55 2.1654	44 1.7323	14.5 0.5709	122850	86500	4.30
UK317	85 3.3465	180 7.0866	60 2.3622	46 1.8110	15.5 0.6102	132600	96500	5.00
UK318	90 3.5433	190 7.4803	60 2.3622	48 1.8898	16.5 0.6496	143000	108000	5.65
UK319	95 3.7402	200 7.8740	66 2.5984	50 1.9685	16.7 0.6574	156000	122000	6.58
UK320	100 3.9370	215 8.4646	68 2.6772	54 2.1260	19 0.7480	171600	140000	8.40
UK322	110 4.3307	240 9.4488	80 3.1496	60 2.3622	21 0.8268	158000	178000	11.7
UK324	120 4.7244	260 10.2362	87 3.4252	64 2.5196	22 0.8661	175000	208000	14.9
UK326	130 5.1181	280 11.0236	90 3.5433	68 2.6771	23 0.9055	195000	242000	18.2
UK328	140 5.5118	300 11.8110	98 3.8583	72 2.8346	25 0.9843	212000	272000	22.5



# BALL BEARING INSERTS

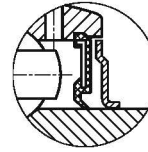
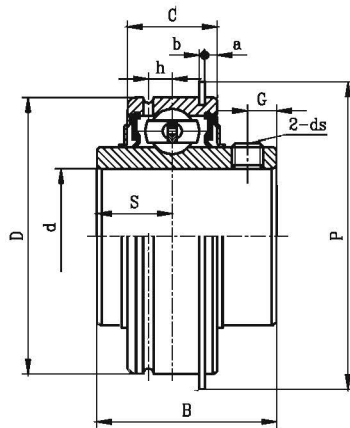

Dual seals

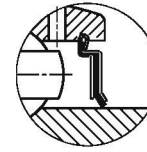

F seal  
(+Suffix-F)

## ER2 Setscrew type

Unit No.	Shaft Dia.		Dimensions(mm)/(in.)										Basic load rating (N)		Mass (kg)		
	d		D	B	C	S	a	b	p	G	h	ds	Dynamic Cr	Static Cor			
	(in.)	(mm)															
ER201		12													0.22		
201-8	1/2	15													0.21		
202		15													0.20		
202-10	5/8	17	47	31	15.9	12.7	2.38	1.07	52.7	4.7	4.4	M6X1	12800	6650	0.20		
203		17	1.8504	1.2205	0.6260	0.5000	0.0937	0.0421	2.0748	0.1850	0.1732	1/4-28UNF			0.19		
203-11	11/16	20															0.19
204-12	3/4	20															0.18
204		20													0.17		
ER205-14	7/8														0.25		
205-15	15/16														0.23		
205		25	52	34	19	14.3	2.38	1.07	57.9	5.5	4.5	M6X1	14000	7880	0.22		
205-16	1	25	2.0472	1.3386	0.7480	0.5630	0.0937	0.0421	2.2795	0.2165	0.1772	1/4-28UNF			0.21		
ER206-18	1-1/8														0.37		
206		30	62	38.1	22.2	15.9	3.18	1.65	67.7	5.5	5.3	M6X1	19500	11200	0.35		
206-19	1-3/16	30	2.4409	1.5000	0.8740	0.6260	0.1252	0.0650	2.6654	0.2165	0.2087	1/4-28UNF			0.35		
206-20	1-1/4	30															0.33
ER207-20	1-1/4																0.58
207-21	1-5/16														0.55		
207-22	1-3/8	35	72	42.9	23.8	17.5	3.18	1.65	78.6	6.5	5.8	M8X1	25700	15200	0.53		
207		35	2.8346	1.6890	0.9370	0.6890	0.1252	0.0650	3.0945	0.2559	0.2283	5/16-24UNF			0.53		
207-23	1-7/16	35															0.50
ER208-24	1-1/2																0.78
208-25	1-9/16														0.75		
208		40	80	49.2	27.8	19	3.18	1.65	86.6	8	6.3	M8X1	29600	18200	0.73		
ER209-26	1-5/8																0.86
209-27	1-11/16														0.83		
209-28	1-3/4	45	85	49.2	27.8	19	3.18	1.65	91.6	8	7.5	M8X1	31850	20800	0.78		
209		45	3.3465	1.9370	1.0945	0.7480	0.1252	0.0650	3.6063	0.3150	0.2953	5/16-24UNF			0.77		
ER210-30	1-7/8														0.91		
210-31	1-15/16														0.88		
210		50	90	51.6	28.6	19	3.18	2.41	96.5	9	6.8	M10X1.25	35100	23200	0.84		
ER211-32	2																1.31
211-34	2-1/8														1.20		
211		55	100	55.6	30.2	22.2	3.18	2.41	106.5	9	7.6	M10X1.25	43550	29200	1.16		
211-35	2-3/16	55	3.9370	2.1890	1.1890	0.8740	0.1252	0.0949	4.1929	0.3543	0.2992	3/8-24UNF			1.14		
ER212-36	2-1/4																1.67
212		60	110	65.1	31.8	25.4	3.18	2.41	116.6	10.5	8.4	M10X1.25			47800	32800	1.54
212-38	2-3/8	60	4.3307	2.5630	1.2520	1.0000	0.1252	0.0949	4.5906	0.4134	0.3307	3/8-24UNF	1.52				
212-39	2-7/16	60															1.45
ER214-40	2-1/2																2.57
214-43	2-11/16														2.28		
214		70	125	74.6	34.9	30.2	3.96	2.77	134.7	12	9	M12X1.25	60800	45000	2.17		
ER215-46	2-7/8																2.59
215-47	2-15/16														2.47		
215		75	130	77.8	38.1	33.3	3.96	2.77	139.7	12	9.5	M12X1.25	66000	49500	2.45		



# BALL BEARING INSERTS

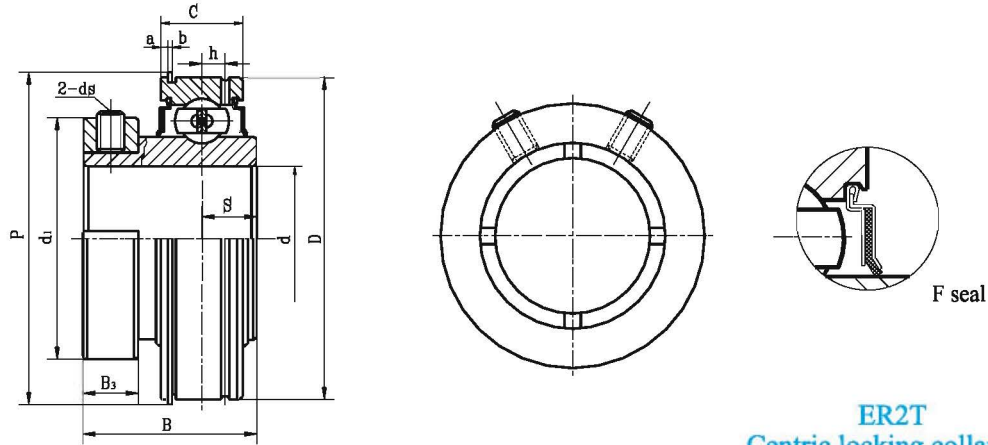

**ER2T**  
Centric locking collar type

Unit No.	Shaft Dia.		Dimensions(mm)/(in).											Basic load rating (N)		Mass (kg)
	(in.)	(mm)	D	B	C	S	a	b	p	B <sub>3</sub>	h	d <sub>1</sub> (mm)	d <sub>s</sub>	Dynamic Cr	Static Cor	
ER204-12T 204T	3/4	20	47 1.8504	31 1.2205	15.9 0.6260	10.3 0.4055	2.38 0.0937	1.07 0.0421	52.7 2.0748	8.0 0.3150	4.4 0.1732	34.9	M5X0.8 10#-32UNF	12800	6650	0.27
ER205-13T 205-14T 205-15T 205T 205-16T	13/16 7/8 15/16 1	25	52 2.0472	34.9 1.3740	19 0.7480	13.1 0.5157	2.38 0.0937	1.07 0.0421	57.9 2.2795	8.8 0.3465	4.5 0.1772	34.9 39.7 39.7 39.7	M6X1 1/4-28UNF	14000	7880	0.30
ER206-16T 206-17T 206-18T 206T 206-19T 206-20T	1 1-1/16 1-1/8 206T 1-3/16 1-1/4	30	62 2.4409	38.1 1.5000	22.2 0.8740	15.9 0.6260	3.18 0.1252	1.65 0.0650	67.7 2.6654	8.8 0.3465	5.3 0.2087	46.0 46.0 46.0 50.8 50.8	M6X1 1/4-28UNF	19500	11200	0.42
ER207-19T 207-20T 207-21T 207-22T 207T 207-23T	1-3/16 1-1/4 1-5/16 1-3/8 207T 1-7/16	35	72 2.8346	42.9 1.6890	23.8 0.9370	17.5 0.6890	3.18 0.1252	1.65 0.0650	78.6 3.0945	11.2 0.4409	5.8 0.2283	50.8 50.8 57.2 57.2 57.2	M8X1 5/16-24UNF	25700	15200	0.66
ER208-23T 208-24T 208-25T 208T 208-26T	1-7/16 1-1/2 1-9/16 208T 1-5/8	40	80 3.1496	49.2 1.9370	27.8 1.0945	19 0.7480	3.18 0.1252	1.65 0.0650	86.6 3.4094	11.2 0.4409	6.3 0.2480	63.5	M8X1 5/16-24UNF	29600	18200	0.86
ER209-24T 209-26T 209-27T 209-28T 209T 209-29T	1-1/2 1-5/8 1-11/16 1-3/4 209T 1-13/16	45	85 3.3465	49.2 1.9370	27.8 1.0945	19 0.7480	3.18 0.1252	1.65 0.0650	91.6 3.6063	11.2 0.4409	7.5 0.2953	63.5 63.5 68.3 68.3 68.3	M8X1 5/16-24UNF	31850	20800	0.95
ER210-27T 210-28T 210-29T 210-30T 210-31T 210T 210-32T	1-11/16 1-3/4 1-13/16 210-30T 1-7/8 1-15/16 210T 2	50	90 3.5433	51.6 2.0315	28.6 1.1260	19 0.7480	3.18 0.1252	2.41 0.0949	96.5 3.7992	14.2 0.5591	6.8 0.2677	69.9 69.9 69.9 73.0 73.0 73.0	M10X1.25 3/8-24UNF	35100	23200	1.03
ER211-31T 211-32T 211-33T 211-34T 211T 211-35T 211-36T	1-15/16 2 2-1/16 2-1/8 211T 2-3/16 2-1/4	55	100 3.9370	55.6 2.1890	30.2 1.1890	22.2 0.8740	3.18 0.1252	2.41 0.0949	106.5 4.1929	14.2 0.5591	7.6 0.2992	73.0 73.0 79.4 79.4 79.4 79.4	M10X1.25 3/8-24UNF	43550	29200	1.48
ER212-35T 212-36T 212-37T 212T 212-38T 212-39T	2-3/16 2-1/4 2-5/16 212T 2-3/8 2-7/16	60	110 4.3307	65.1 2.5630	31.8 1.2520	25.4 1.000	3.18 0.1252	2.41 0.0949	116.6 4.5906	14.2 0.5591	8.4 0.3307	79.4 79.4 85.7 85.7 85.7	M10X1.25 3/8-24UNF	47800	32800	2.02
ER214-40T 214-42T 214-43T 214T	2-1/2 2-5/8 2-11/16	70	125 4.9213	74.6 2.9370	34.9 1.3740	30.2 1.1890	3.96 0.1559	2.77 0.1091	134.7 5.3031	14.2 0.5591	9 0.3543	100	M10X1.25 3/8-24UNF	60800	45000	2.66
ER215-44T 215-45T 215-46T 215-47T 215T	2-3/4 2-13/16 2-7/8 2-15/16 215T	75	130 5.1181	77.8 3.0630	38.1 1.5000	33.3 1.3110	3.96 0.1559	2.77 0.1091	139.7 5.5000	14.2 0.5591	9.5 0.3740	100.0 106.4 106.4 106.4	M10X1.25 3/8-24UNF	66000	49500	3.10



# BALL BEARING INSERTS

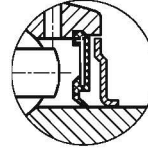
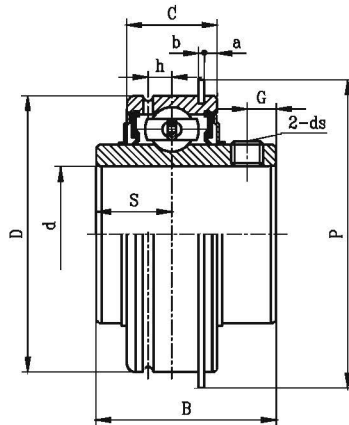

Dual seals

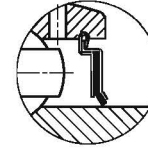

F seal  
(+Suffix-F)

## SER2 Setscrew type

Unit No.	Shaft Dia.		Dimensions(mm)/(in.)										Basic load rating (N)		Mass (kg)
	d		D	B	C	S	a	b	p	G	h	ds	Dynamic Cr	Static Cor	
	(in.)	(mm)													
SER201 201-8 202 202-10 203 203-11 204-12 204	1/2 5/8 11/16 3/4 20	12 15 17 19 20	47 1.8504	31 1.2205	15.9 0.6260	10.3 0.4055	2.38 0.0937	1.07 0.0421	52.7 2.0748	4.7 0.1850	4.4 0.1732	M6X1 1/4-28UNF	12800	6650	0.22 0.21 0.20 0.20 0.19 0.19 0.18 0.17
SER205-14 205-15 205 205-16	7/8 15/16 25 1	25	52 2.0472	34.9 1.3740	19 0.7480	13.1 0.5157	2.38 0.0937	1.07 0.0421	57.9 2.2795	5.5 0.2165	4.5 0.1772	M6X1 1/4-28UNF	14000	7880	0.25 0.23 0.22 0.21
SER206-18 206 206-19 206-20	1-1/8 1-3/16 1-1/4	30	62 2.4409	38.1 1.5000	22.2 0.8740	15.9 0.6260	3.18 0.1252	1.65 0.0650	67.7 2.6654	5.5 0.2165	5.3 0.2087	M6X1 1/4-28UNF	19500	11200	0.37 0.35 0.35 0.33
SER207-20 207-21 207-22 207 207-23	1-1/4 1-5/16 1-3/8 1-7/16	35	72 2.8346	42.9 1.6890	23.8 0.9370	17.5 0.6890	3.18 0.1252	1.65 0.0650	78.6 3.0945	6.5 0.2559	5.8 0.2283	M8X1 5/16-24UNF	25700	15200	0.58 0.55 0.53 0.53 0.50
SER208-24 208-25 208	1-1/2 1-9/16 40	40	80 3.1496	49.2 1.9370	27.8 1.0945	19 0.7480	3.18 0.1252	1.65 0.0650	86.6 3.4094	8 0.3150	6.3 0.2480	M8X1 5/16-24UNF	29600	18200	0.78 0.75 0.73
SER209-26 209-27 209-28 209	1-5/8 1-11/16 1-3/4 45	45	85 3.3465	49.2 1.9370	27.8 1.0945	19 0.7480	3.18 0.1252	1.65 0.0650	91.6 3.6063	8 0.3150	7.5 0.2953	M8X1 5/16-24UNF	31850	20800	0.86 0.83 0.78 0.77
SER210-30 210-31 210	1-7/8 1-15/16 50	50	90 3.5433	51.6 2.0315	28.6 1.1260	19 0.7480	3.18 0.1252	2.41 0.0949	96.5 3.7992	9 0.3543	6.8 0.2677	M10X1.25 3/8-24UNF	35100	23200	0.91 0.88 0.84
SER211-32 211-34 211 211-35	2 2-1/8 2-3/16	55	100 3.9370	55.6 2.1890	30.2 1.1890	22.2 0.8740	3.18 0.1252	2.41 0.0949	106.5 4.1929	9 0.3543	7.6 0.2992	M10X1.25 3/8-24UNF	43550	29200	1.31 1.20 1.16 1.14
SER212-36 212 212-38 212-39	2-1/4 2-3/8 2-7/16	60	110 4.3307	65.1 2.5630	31.8 1.2520	25.4 1.0000	3.18 0.1252	2.41 0.0949	116.6 4.5906	10.5 0.4134	8.4 0.3307	M10X1.25 3/8-24UNF	47800	32800	1.67 1.54 1.52 1.45
SER214-40 214-43 214	2-1/2 2-11/16 70	70	125 4.9213	74.6 2.9370	34.9 1.3740	30.2 1.1890	3.96 0.1559	2.77 0.1091	134.7 5.3031	12 0.4724	9 0.3543	M12X1.25 7/16-20UNF	60800	45000	2.57 2.28 2.17
SER215-46 215-47 215	2-7/8 2-15/16 75	75	130 5.1181	77.8 3.0630	38.1 1.5000	33.3 1.3110	3.96 0.1559	2.77 0.1091	139.7 5.5000	12 0.4724	9.5 0.3740	M12X1.25 7/16-20UNF	66000	49500	2.59 2.47 2.45



# BALL BEARING INSERTS

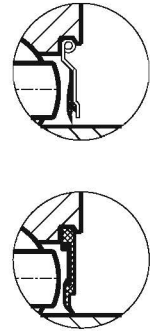
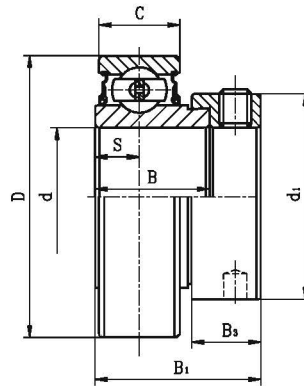
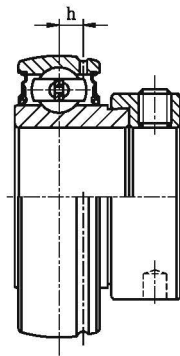
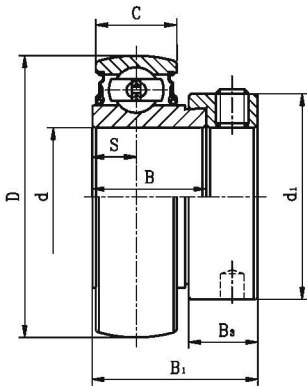

RS Seal  
(+Suffix-2RS)

## SA2

Eccentric locking collar type

## SA2G

Relubricatable type

## CSA2

Cylindrical O.D. type

Unit No.	Shaft Dia.		Dimensions(mm)/(in.)								Basic load rating(N)		Mass (kg)								
	d		D	C	B	B <sub>1</sub>	S	h	B <sub>3</sub>	d <sub>1</sub>	Dynamic Cr	Static Cor									
	(in.)	(mm)																			
SA201	1/2	12	40	12	19.1	28.6	6.5	3.6	13.5	27.2	9550	4780	0.13								
201-8		0.13																			
202		0.12																			
202-10		0.11																			
203		0.10																			
203-11	17	0.10																			
SA204-12	3/4	20	47	14	21.4	30.9	7.5	4	13.5	32.4	12800	6650	0.17								
204			1.8504	0.5512	0.8425	1.2165	0.2953	0.1575	0.5315	1.2756			0.16								
SA205-14	7/8	25	52	15	21.4	30.9	7.5	4.3	13.5	37.4	14000	7880	0.21								
205-15													0.20								
205													0.19								
205-16													1	0.19							
SA206-18	1-1/8	30	62	16	23.8	35.7	9	5	15.9	44.1	19500	11200	0.32								
206													0.30								
206-19													1-3/16	0.39							
206-20	1-1/4	0.28																			
SA207-20	1-1/4	35	72	17	25.4	38.9	9.5	5.7	17.5	51.1	25700	15200	0.51								
207-21													0.48								
207-22													1-3/8	0.45							
207													0.45								
207-23													1-7/16	0.43							
SA208-24	1-1/2	40	80	18	30.2	43.7	11	6.2	18.3	58	29600	18200	0.65								
208-25													1-9/16	0.62							
208													0.61								
SA209-26	1-5/8	45	85	19	30.2	43.7	11	6.5	18.3	63.5	31850	20800	0.75								
209-27													1-11/16	0.71							
209-28													1-3/4	0.67							
209													0.66								
SA210-30	1-7/8	50	90	20	30.2	43.7	11	6.5	18.3	67.2	35100	23200	0.76								
210-31													1-15/16	0.72							
210													0.70								
SA211-32	2	55	100	24	32.5	48.4	12	7.2	20.7	74.5	43550	29200	1.17								
211-34													2-1/8	1.07							
211													0.9449	1.04							
211-35													2-3/16	1.02							
SA212-36	2-1/4	60	110	24	33.4	49.3	12	8	22.3	82	47800	32800	1.36								
212													4.3307	0.9449	1.3150	1.9409	0.4724	0.3150	0.8780	3.2283	1.26
212-38													2-3/8	1.25							
212-39													2-7/16	1.19							

Note: Suffix "G"-Relub; Prefix "C"-Cylindrical O. D..

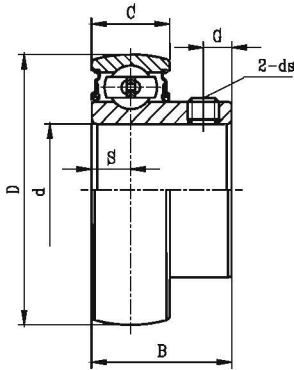

**SB2**  
Setscrew type

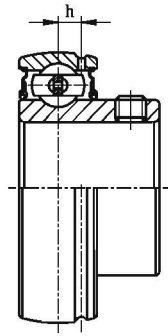

**SB2G**  
Relubricatable type

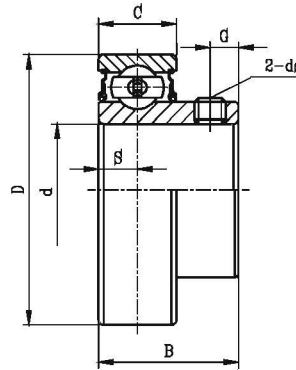

**CSB2**  
Cylindrical O.D. type

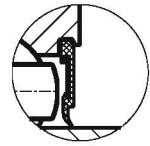
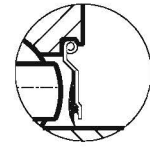

RS Seal  
(+Suffix-2RS)

Unit No.	Shaft Dia.		Dimensions(mm)/(in.)							Basic load rating(N)		Mass (kg)
	d		D	B	C	S	h	G	ds	Dynamic Cr	Static Cor	
	(in.)	(mm)										
SB201		12										0.11
201-8	1/2	15	40	22	12	6	3.6	4	M5X0.8	9550	4780	0.11
202		17	1.5748	0.8661	0.4724	0.2362	0.1417	0.1575	10#-32UNF			0.10
202-10	5/8											0.10
203		17										0.09
203-11	11/16											0.09
SB204-12	3/4	20	47	25	14	7	4	5	M6X1	12800	6650	0.14
204		20	1.8504	0.9843	0.5512	0.2756	0.1575	0.1969	1/4-28UNF			0.13
SB205-14	7/8									14000	7880	0.19
205-15	15/16	25	52	27	15	7.5	4.3	5.5	M6X1			0.18
205		25	2.0472	1.0630	0.5906	0.2953	0.1693	0.2165	1/4-28UNF			0.17
205-16	1											0.16
SB206-18	1-1/8	30	62	30	16	8	5	6	M6X1			19500
206		30	2.4409	1.1811	0.6299	0.3150	0.1969	0.2362	1/4-28UNF	0.25		
206-19	1-3/16									0.25		
206-20	1-1/4									0.23		
SB207-20	1-1/4									25700	15200	0.43
207-21	1-5/16											0.41
207-22	1-3/8	35	72	32	17	8.5	5.7	6.5	M6X1			0.39
207		35	2.8346	1.2598	0.6693	0.3346	0.2244	0.2559	1/4-28UNF			0.39
207-23	1-7/16											0.37
SB208-24	1-1/2									29600	18200	0.51
208-25	1-9/16	40	80	34	18	9	6.2	7	M8X1			0.49
208		40	3.1496	1.3386	0.7087	0.3543	0.2441	0.2756	5/16-24UNF			0.48
SB209-26	1-5/8									31850	20800	0.64
209-27	1-11/16											0.61
209-28	1-3/4	45	85	41.2	19	10.2	6.5	8.2	M8X1			0.57
209		45	3.3465	1.6220	0.7480	0.4016	0.2559	0.3228	5/16-24UNF			0.56
SB210-30	1-7/8									35100	23200	0.69
210-31	1-15/16											0.65
210		50	90	43.5	20	10.9	6.5	9.2	M8X1			0.63
SB211-32	2									43550	29200	1.04
211-34	2-1/8	55	100	45.3	23	11.8	7.2	9.8	M8X1			0.95
211		55	3.9370	1.7835	0.9055	0.4646	0.2835	0.3858	5/16-24UNF			0.92
211-35	2-3/16											0.90
SB212-36	2-1/4									47800	32800	1.28
212		60	110	53.7	24	14.9	8	9.8	M10X1.25			1.17
212-38		60	4.3307	2.1142	0.9449	0.5866	0.3150	0.3858	3/8-24UNF			1.17
212-39	2-7/16											1.16
												1.09

Note: Suffix "G" - Relub; Prefix "C" - Cylindrical O. D..

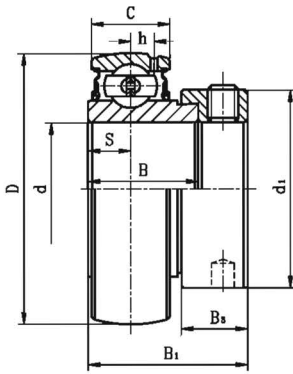

**GRA2**

Eccentric locking collar type

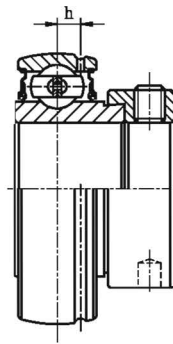

**GRA2G**

Relubricatable type

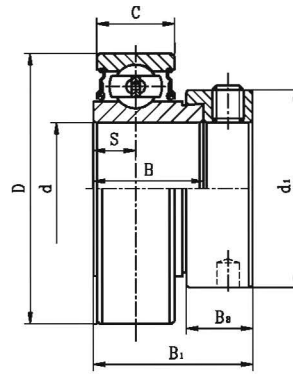

**RA2**

Cylindrical O.D. type

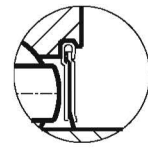
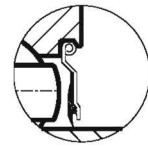

F Seal  
(+Suffix-F)

Unit No.	Shaft Dia.		Dimensions(mm)/(in.)								Basic load rating(N)		Mass (kg)
	d		D	C	h	S	B <sub>1</sub>	B	B <sub>2</sub>	d <sub>1</sub>	Dynamic Cr	Static Cor	
	(in.)	(mm)											
GRA201 RA201-8	1/2	12											0.13
202		15	40	12	3.6	6.5	28.6	19.1	13.5	27.2	9550	4780	0.13
202-10	5/8	17	1.5748	0.4724	0.1417	0.2559	1.1260	0.7520	0.5315	1.0709			0.12
203													0.11
203-11	11/16												0.10
GRA204-12 RA204	3/4	20	47	14	4	7.5	30.9	21.4	13.5	32.4	12800	6650	0.17
			1.8504	0.5511	0.1575	0.2953	1.2165	0.8425	0.5315	1.2756			0.16
GRA205-14 205-15	7/8		52	15	4.3	7.5	30.9	21.4	13.5	37.4	14000	7880	0.21
205	15/16	25	2.0472	0.5906	0.1693	0.2953	1.2165	0.8425	0.5315	1.4724			0.20
205-16	1												0.19
GRA206-18 RA206	1-1/8	30	62	18	5	9	35.7	23.8	15.9	44.1	19500	11200	0.33
206-19	1-3/16		2.4409	0.7087	0.1969	0.3543	1.4055	0.9370	0.6260	1.7362			0.31
206-20	1-1/4												0.31
GRA207-20 RA207-21	1-1/4		72	19	5.7	9.5	38.9	25.4	17.5	51.1	25700	15200	0.52
207-22	1-5/16	35	2.8346	0.7480	0.2244	0.3740	1.5315	1.0000	0.6890	2.0118			0.49
207	1-3/8												0.46
207-23	1-7/16												0.46
GRA208-24 RA208-25	1-1/2		80	21	6.3	11	43.7	30.2	18.3	58	29600	18200	0.67
208	1-9/16	40	3.1496	0.8268	0.2480	0.4331	1.7205	1.1890	0.7205	2.2835			0.64
GRA209-26 RA209-27	1-5/8		85	22	6.8	11	43.7	30.2	18.3	63.5	31850	20800	0.77
209-28	1-11/16	45	3.3465	0.8661	0.2677	0.4331	1.7205	1.1890	0.7205	2.5000			0.73
209	1-3/4												0.69
GRA210-30 RA210-31	1-7/8		90	22	6.5	11	43.7	30.2	18.3	67.2	35100	23200	0.77
210	1-15/16	50	3.5433	0.8661	0.2559	0.4331	1.7205	1.1890	0.7205	2.6457			0.73
GRA211-32 RA211-34	2		100	24	7.2	12	48.4	32.5	20.7	74.5	43550	29200	1.17
211	2-1/8	55	3.9370	0.9449	0.2835	0.4724	1.9055	1.2795	0.8150	2.9331			1.04
211-35	2-3/16												1.02
GRA212-36 RA212	2-1/4	60	110	24	8	13.5	53.1	37.2	22.3	82	47800	32800	1.41
212-38	2-3/8		4.3307	0.9449	0.3150	0.5315	2.0906	1.4646	0.8780	3.2283			1.31
212-39	2-7/16												1.30



# BALL BEARING INSERTS

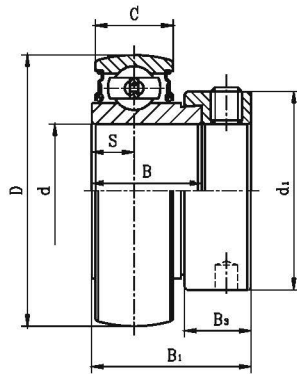

**SA0**  
Eccentric locking collar type

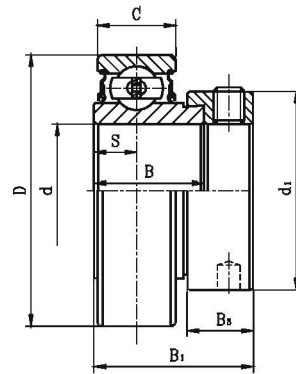

**CSA0**  
Cylindrical O.D. type

Unit No.	Shaft Dia.		Dimensions(mm)/(in.)							Basic load rating(N)		Mass (kg)
	d		D	C	B	B <sub>1</sub>	S	B <sub>3</sub>	d <sub>1</sub>	Dynamic Cr	Static Cor	
	(in.)	(mm)										
SA 004-12 004	3/4	20	42 1.6535	12 0.4724	16.7 0.6563	24.6 0.9688	6 0.2362	11.1 0.4375	29.8 1.1719	9380	5020	0.09
SA 005-14 005-15 005	7/8 15/16	25	47 1.8504	12 0.4724	17.5 0.6875	25.4 1.0000	6 0.2362	11.9 0.4688	36.1 1.4219	10000	5850	0.12
SA 005-16 005-16	1											
SA 006-18 006	1-1/8	30	55 2.1654	13 0.5118	18.5 0.7283	26.5 1.0433	6.5 0.2559	11.9 0.4688	42.5 1.6719	13200	8300	0.17
SA 006-19 006-19	1-3/16											
SA 006-20 006-20	1-1/4											

Note: Prefix "C" -Cylindrical O. D.

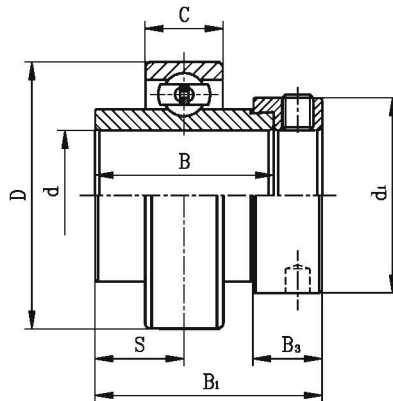

**NAA3**  
Cylindrical O.D., Eccentric locking collar type

Unit No.	Shaft Dia.		Dimensions(mm)/(in.)							Eccentric collar	Basic load rating(N)		Mass (kg)
	d		D	B	C	S	B <sub>1</sub>	B <sub>3</sub>	d <sub>1</sub>		Dynamic Cr	Static Cor	
	(in.)	(mm)											
NAA306-18 306	1-1/8	30	72 2.8346	36.5 1.4370	19 0.7480	17.5 0.6890	50 1.9685	17.5 0.6890	50 1.9685	A306-18 306 306-19	27000	15200	0.71 0.68 0.68
306-19	1-3/16												
NAA310-30 310-31 310	1-7/8 1-15/16	50	110 4.3307	49.2 1.9370	27 1.0630	24.6 0.9685	66.6 2.6220	22.2 0.8740	76.2 3.0000	A310-30 310-31 310	61750	37800	1.93 1.87 1.84





# BALL BEARING INSERTS

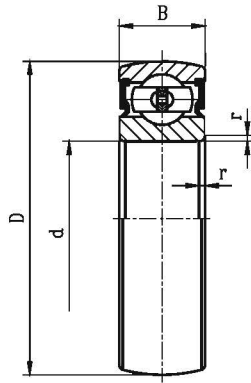

## CS2 Series

Unit No.	Dimensions(mm)/(in).				Basic load rating(N)		Mass (kg)
	d	D	B	r(min)	Dynamic Cr	Static Cor	
CS203	17	40	12	0.6	9580	4780	0.050
CS204	20	47	14	1	12800	6650	0.095
CS205	25	52	15	1	14000	7880	0.11
CS206	30	62	16	1	19500	11500	0.18
CS207	35	72	17	1.1	25500	15200	0.25
CS208	40	80	18	1.1	29500	18000	0.32
CS209	45	85	19	1.1	31500	20800	0.37
CS210	50	90	20	1.1	35000	23200	0.41

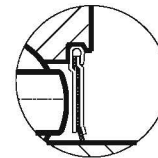
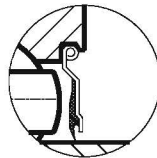
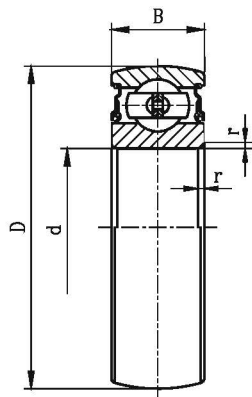

F seal  
(+suffix-F)

## ORAE Series

Unit No.	Dimensions(mm)/(in).				Basic load rating(N)		Mass (kg)
	d	D	B	r(min)	Dynamic Cr	Static Cor	
ORAE203	17	40	12	0.6	9580	4780	0.05
ORAE204	20	47	14	0.6	12800	6650	0.095
ORAE205	25	52	15	0.6	14000	7880	0.11
ORAE206	30	62	18	0.6	19500	11500	0.21
ORAE207	35	72	19	1.1	25700	15200	0.29
ORAE208	40	80	22	1.1	29500	18200	0.38
ORAE209	45	85	22	1.1	31850	20800	0.44



## Tri-Ply Seal Series Non-Relubricatable type

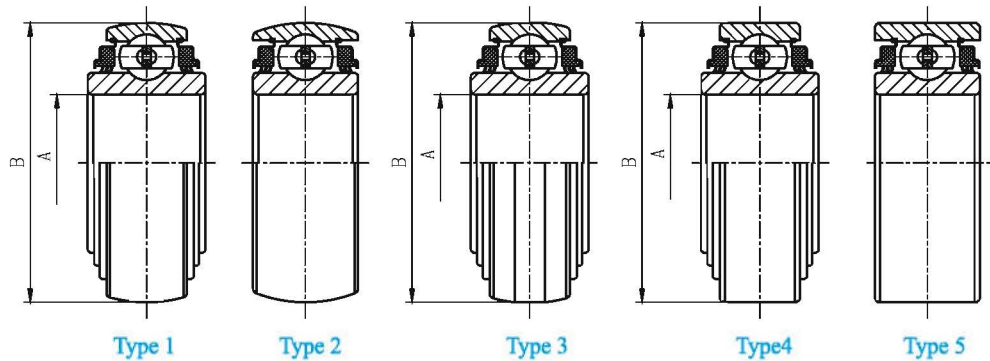

### ROUND BORE

Unit No.	Type	Bearing Bore Size		Outside Dia.		Ring Width			
		A		B		Inner Ring		Outer Ring	
		(in.)	(mm)	(in.)	(mm)	(in.)	(mm)	(in.)	(mm)
205PPB7	1	0.9375	23.813	2.0472	52	1.3748	34.92	0.591	15
W208PPB7	1	1.1880	30.175	3.1496	80	1.189	30.2	0.709	18
W208PP10	4	1.5005	38.113	3.1496	80	1.691	42.96	0.827	21
W208PPB23	1	1.5005	38.113	3.1496	80	1.691	42.96	1.189	30.2
W209PPB2	2	1.7717	45	3.3460	85	1.189	30.2	1.189	30.2
W209PPB4	2	1.5350	39	3.3460	85	1.189	30.2	1.189	30.2
W210PP2	5	1.9380	49.225	3.5433	90	1.189	30.2	1.189	30.2
W210PPB2	2	1.9380	49.225	3.5433	90	1.189	30.2	1.189	30.2
W211PP2	5	2.1880	55.575	3.9370	100	1.313	33.34	1.313	33.34
W211PPB2	2	2.1880	55.575	3.9370	100	1.313	33.34	1.313	33.34

### SQUARE BORE

Bearing No.	Type	Square Shaft Size	Square Bore Size	Outside Dia.		Ring Width			
				B		Inner Ring		Outer Ring	
				(in.)	(mm)	(in.)	(mm)	(in.)	(mm)
W208PPB13	1	7/8	23.117	3.1496	80	1.437	36.5	0.709	18
W208PPB6	1	1	26.162	3.1496	80	1.437	36.5	0.709	18
W208PP5	4	1-1/8	29.972	3.1496	80	1.437	36.5	0.709	18
W208PPB5	1	1-1/8	29.972	3.1496	80	1.437	36.5	0.709	18
W208PP8	4	1-1/8	29.972	3.1496	80	1.437	36.5	1.189	30.2
W208PPB8	1	1-1/8	29.972	3.1496	80	1.437	36.5	1.189	30.2
W208PPB11	3	7/8	23.117	3.3760	85.75	1.437	36.5	1.189	30.2
W208PPB12	3	1-1/8	29.972	3.3760	85.75	1.437	36.5	1.189	30.2
W209PPB5	1	1-1/4	32.766	3.3460	85	1.437	36.5	1.189	30.2
W210PP4	5	1-1/8	29.972	3.5433	90	1.189	30.2	1.189	30.2
W210PPB4	2	1-1/8	29.972	3.5433	90	1.189	30.2	1.189	30.2
W211PP3	5	1-1/2	38.89	3.9370	100	1.313	33.34	1.313	33.34
W211PPB3	2	1-1/2	38.89	3.9370	100	1.313	33.34	1.313	33.34
W211PP5	4	1-1/2	38.89	4.0000	101.6	1.750	44.45	1.438	36.52
W211PPB6	3	1-1/2	38.89	4.0772	103.56	1.750	44.45	1.438	36.52



## Tri-Ply Seal Series Relubricatable type

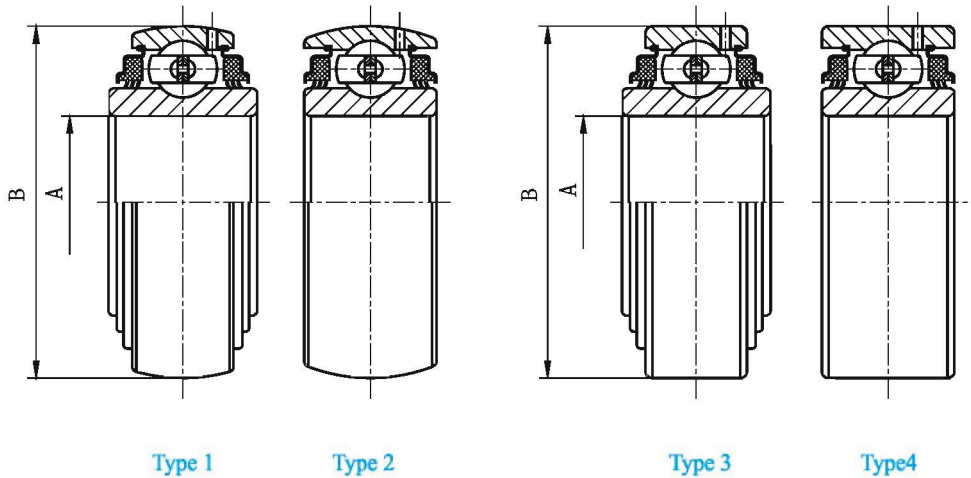

### ROUND BORE

Unit No.	Type	Bearing Bore Size		Outside Dia.		Ring Width			
		A		B		Inner Ring		Outer Ring	
		(in.)	(mm)	(in.)	(mm)	(in.)	(mm)	(in.)	(mm)
205PPB7G	1	0.9375	23.813	2.0472	52	1.375	34.92	0.591	15
GW209PPB4	2	1.5350	39	3.3465	85	1.189	30.2	1.189	30.2
GW209PPB2	2	1.7717	45	3.3465	85	1.189	30.2	1.189	30.2
GW209PPB11	1	1.7810	45.24	3.3465	85	1.437	36.5	0.866	22
GW210PPB2	2	1.9380	49.225	3.5433	90	1.189	30.2	1.189	30.2
GW211PPB2	2	2.1880	55.575	3.9370	100	1.313	33.34	1.313	33.34

### SQUARE BORE

Unit No.	Type	Square Shaft Size	Square Bore Size	Outside Dia.		Ring Width			
				B		Inner Ring		Outer Ring	
		(in.)	(mm)	(in.)	(mm)	(in.)	(mm)	(in.)	(mm)
GW208PPB5	1	1-1/8	29.972	3.1496	80	1.437	36.5	0.827	21
GW208PPB8	1	1-1/8	29.972	3.1496	80	1.437	36.5	1.189	30.2
GW208PPB17	1	1-1/8	29.972	3.3755	85.738	1.437	36.5	1.189	30.2
GW209PPB5	1	1-1/4	32.766	3.3465	85	1.437	36.5	1.189	30.2
GW209PPB8	1	1-1/4	32.766	3.3465	85	1.437	36.5	0.866	22
GW210PP4	4	1-1/8	29.972	3.5433	90	1.189	30.2	1.189	30.2
GW210PPB4	2	1-1/8	29.972	3.5433	90	1.189	30.2	1.189	30.2
GW211PP3	4	1-1/2	38.89	3.9370	100	1.313	33.34	1.313	33.34
GW211PPB3	2	1-1/2	38.89	3.9370	100	1.313	33.34	1.313	33.34
GW211PP17	3	1-1/2	38.89	3.9370	100	1.750	44.45	1.313	33.34

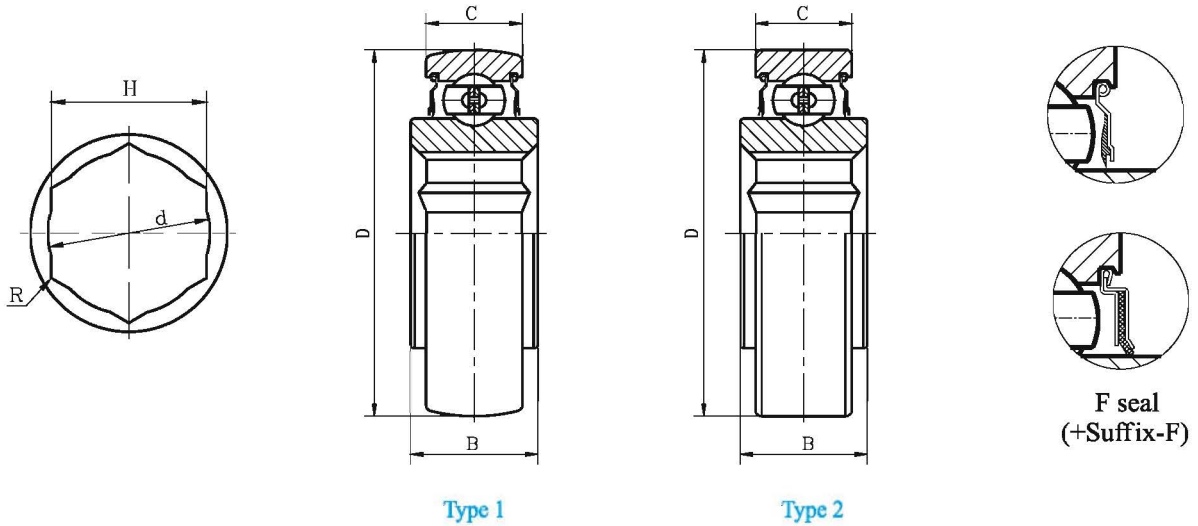

### Hex-bore

Unit No.	Type	Dimensions(mm)/(in).						Basic load rating (N)		Mass (kg)
		H	d	R	D	B	C	Dynamic Cr	Static Cor	
205NPPB AH02	1	22.25 0.8760	22.7 0.8937	0.2 0.0079	52 2.0472	25.4 1.0000	15 0.5906	14000	7880	0.20
206NPPB AH02	1	22.25 0.8760	22.7 0.8937	0.2 0.0079	62 2.4409	24 0.9449	18 0.7087	19500	11200	0.37
206NPPB AH04	1	25.43 1.0012	26 1.0236	0.2 0.0079	62 2.4409	24 0.9449	18 0.7087	19500	11200	0.35
207NPPB AH09	1	28.6 1.1260	29.4 1.1575	0.2 0.0079	72 2.8346	37.7 1.4843	17 0.6693	25700	15200	0.48
207KPP3	2	31.77 1.2508	32.5 1.2795	0.2 0.0079	72 2.8346	37.7 1.4843	17 0.6693	25700	15200	0.45
207KPP17	2	28.6 1.1260	29.4 1.1575	0.2 0.0079	72 2.8346	25 0.9843	17 0.6693	25700	15200	0.42
207KPPB3	1	31.77 1.2508	32.5 1.2795	0.2 0.0079	72 2.8346	25 0.9843	17 0.6693	25700	15200	0.40



# ECCENTRIC LOCKING COLLARS

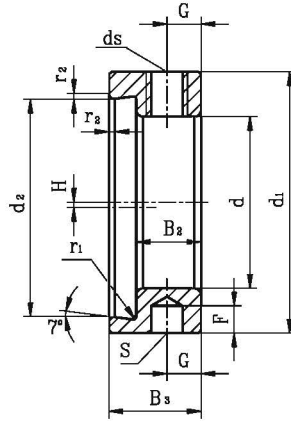

A200

Unit No.	Bore Dia of Collar		Dimensions(mm)/(in.)										
	d		d <sub>1</sub>	d <sub>2</sub>	B <sub>2</sub>	B <sub>3</sub>	H	r <sub>1</sub>	r <sub>2</sub>	G	F	S	d <sub>s</sub>
	(in.)	(mm)											
A201S 201-8S 202S 202-10S 203S 203-11S	1/2 5/8 11/16	12 15 17	27.2 1.0709	21.6 0.8504	9.5 0.3740	13.5 0.5315	0.8 0.0315	0.4 0.0157	0.8 0.0315	5 0.1969	3.5 0.1378	5 0.1969	M6x1 1/4-28UNF
A201 201-8 202 202-10 203 203-11 204-12 204	1/2 5/8 11/16 3/4	12 15 17 20	32.4 1.2756	26.6 1.0472	9.5 0.3740	13.5 0.5315	0.8 0.0315	0.4 0.0157	0.8 0.0315	5 0.1969	4 0.1575	5 0.1969	M6x1 1/4-28UNF
A205-14 205-15 205 205-16	7/8 15/16 1	25	37.4 1.4724	31.6 1.2441	9.5 0.3740	13.5 0.5315	0.8 0.0315	0.4 0.0157	0.8 0.0315	5 0.1969	4 0.1575	5 0.1969	M6x1 1/4-28 UNF
A206-18 206 206-19 206-20	1-1/8 1-3/16 1-1/4	30	44.1 1.7362	37.9 1.4921	11.9 0.4685	15.9 0.6260	0.8 0.0315	0.4 0.0157	0.8 0.0315	6 0.2362	4 0.1575	7 0.2756	M8x1 5/16-24 UNF
A207-20 207-21 207-22 207 207-23	1-1/4 1-5/16 1-3/8 1-7/16	35	51.1 2.0118	44.7 1.7598	13.5 0.5315	17.5 0.6890	0.8 0.0315	0.4 0.0157	0.8 0.0315	6.5 0.2559	5 0.1969	7 0.2756	M8x1 5/16-24 UNF
A208-24 208-25 208	1-1/2 1-9/16	40	58 2.2835	49.4 1.9449	13.5 0.5315	18.3 0.7205	1.6 0.0630	0.4 0.0157	1.2 0.0472	6.5 0.2559	5 0.1969	7 0.2756	M8x1 5/16-24UNF
A209-26 209-27 209-28 209	1-5/8 1-11/16 1-3/4	45	63.5 2.5000	54.4 2.1417	13.5 0.5315	18.3 0.7205	1.6 0.0630	0.4 0.0157	1.2 0.0472	6.5 0.2559	5 0.1969	7 0.2756	M8x1 5/16-24UNF
A210-30 210-31 210	1-7/8 1-15/16	50	67.2 2.6457	59 2.3228	13.5 0.5315	18.3 0.7205	1.6 0.0630	0.4 0.0157	1.2 0.0472	6.5 0.2559	5 0.1969	7 0.2756	M8x1 5/16-24UNF
A211-32 211-34 211 211-35	2 2-1/8 2-3/16	55	74.5 2.9331	65.8 2.5906	15.9 0.6260	20.7 0.8150	1.6 0.0630	0.6 0.0236	1.2 0.0472	8 0.3150	6 0.2362	8.4 0.3307	M10x1.25 3/8-24UNF
A212-36 212 212-38 212-39	2-1/4 2-3/8 2-7/16	60	82 3.2283	71.7 2.8228	15.9 0.6260	22.3 0.8780	1.6 0.0630	0.6 0.0236	1.6 0.0630	8 0.3150	6 0.2362	8.4 0.3307	M10x1.25 3/8-24UNF
A213-40 213	2-1/2	65	86 3.3858	79 3.1102	17.5 0.6890	23.5 0.9252	1.6 0.0630	0.6 0.0236	1.6 0.0630	8.5 0.3346	6 0.2362	8.4 0.3307	M10x1.25 3/8-24UNF
A214-44 214	2-3/4	70	96.8 3.8110	83.3 3.2795	17.1 0.6732	23.5 0.9252	1.6 0.0630	0.6 0.0236	1.6 0.0630	8.5 0.3346	6 0.2362	8.8 0.3465	M10x1.25 3/8-24UNF
A215 215-48	3	75	102 4.0157	88 3.4646	17.5 0.6890	23.9 0.9409	1.6 0.0630	0.4 0.0157	1.6 0.0630	8.5 0.3346	6 0.2362	8.8 0.3465	M10x1.25 3/8-24UNF
A216		80	110 4.3307	94.6 3.7244	20.6 0.8110	27 1.0630	1.6 0.0630	0.4 0.0157	1.6 0.0630	10.3 0.4055	7 0.2756	10.8 0.4252	M12x1.25
A217-52 217	3-1/4	85	119 4.6850	101 3.9764	20 0.7874	27 1.0630	1.6 0.0630	0.4 0.0157	1.6 0.0630	10 0.3937	8 0.3150	10.8 0.4252	M12x1.25 7/16-20 UNF
A218-56 218	3-1/2	90	120 4.7244	105.5 4.1535	17.5 0.6890	24 0.9449	2.4 0.0945	0.4 0.0157	1.6 0.0630	9.5 0.3740	8 0.3150	10.8 0.4252	M12x1.25 7/16-20 UNF
A220		100	139.7 5.5000	120.2 4.7323	25.4 1.0000	31.8 1.2519	2.4 0.0945	0.4 0.0157	2 0.0787	13 0.5118	10 0.3937	14.4 0.5669	M16x1.5



# ECCENTRIC LOCKING COLLARS

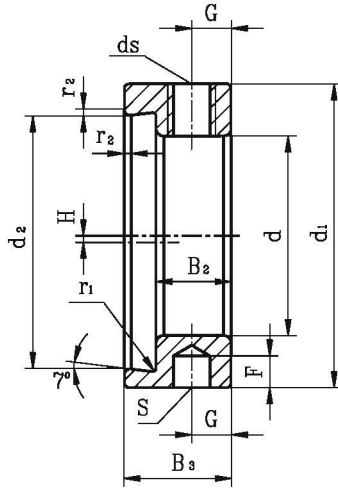

## A300

Unit No.	Bore Dia of Collar		Dimensions(mm)/(in).										
	d		d <sub>1</sub>	d <sub>2</sub>	B <sub>2</sub>	B <sub>3</sub>	H	r <sub>1</sub>	r <sub>2</sub>	G	F	S	d <sub>s</sub>
	(in.)	(mm)											
A305-14 305-15 305 305-16	7/8 15/16 1	25	42.8 1.6850	33.2 1.3071	11.9 0.4685	15.9 0.6260	0.8 0.0315	0.4 0.0157	0.8 0.0315	6 0.2362	5 0.1969	7 0.2756	M8x1 5/16-24UNF
A306-18 306 306-19	1-1/8 1-3/16	30	50 1.9685	42.4 1.6693	13.5 0.5315	17.5 0.6890	0.8 0.0315	0.4 0.0157	0.8 0.0315	6.7 0.2638	5 0.1969	7 0.2756	M8x1 5/16-24UNF
A307-20 307-21 307-22 307 307-23	1-1/4 1-5/16 1-3/8 1-7/16	35	55 2.1654	46.7 1.8386	13.5 0.5315	17.5 0.6890	0.8 0.0315	0.4 0.0157	0.8 0.0315	6.7 0.2638	5 0.1969	7 0.2756	M8x1 5/16-24UNF
A308-24 308-25 308	1-1/2 1-9/16	40	63.5 2.5000	52.7 2.0748	15.8 0.6220	20.6 0.8110	1.6 0.0630	0.4 0.0157	1.2 0.0472	8 0.3150	6 0.2362	8.4 0.3307	M10x1.25 3/8-24UNF
A309-26 309-27 309-28 309	1-5/8 1-11/16 1-3/4	45	70 2.7559	58 2.2835	15.8 0.6220	20.6 0.8110	1.6 0.0630	0.4 0.0157	1.2 0.0472	8 0.3150	6 0.2362	8.4 0.3307	M10x1.25 3/8-24UNF
A310-30 310-31 310	1-7/8 1-15/16	50	76.2 3.0000	64.9 2.5512	17.4 0.6850	22.2 0.8740	1.6 0.0630	0.4 0.0157	1.2 0.0472	8.7 0.3425	6 0.2362	8.4 0.3307	M10x1.25 3/8-24UNF
A311-32 311-34 311 311-35	2 2-1/8 2-3/16	55	83 3.2677	71.7 2.8228	17.4 0.6850	22.2 0.8740	1.6 0.0630	0.4 0.0157	1.2 0.0472	9 0.3543	6 0.2362	8.4 0.3307	M10x1.25 3/8-24UNF
A312-36 312 312-38 312-39	2-1/4 2-3/8 2-7/16	60	89 3.5039	76.2 3.0000	17.5 0.6890	23.9 0.9409	1.6 0.0630	0.4 0.0157	1.6 0.0630	9 0.3543	6 0.2362	8.4 0.3307	M10x1.25 3/8-24UNF
A313-40 313	2-1/2	65	97 3.8189	83.7 3.2953	20.6 0.8110	27 1.0630	1.6 0.0630	0.4 0.0157	1.6 0.0630	11.5 0.4528	8 0.3150	10.5 0.4134	M12x1.25 7/16-20UNF
A314-44 314	2-3/4	70	102 4.0157	90.2 3.5512	23.8 0.9370	30.2 1.1890	1.6 0.0630	0.4 0.0157	1.6 0.0630	12 0.4724	8 0.3150	10.5 0.4134	M12x1.25 7/16-20UNF
A315 315-48	3	75	113 4.4488	96.7 3.8071	25.4 1.0000	31.8 1.2520	1.6 0.0630	0.4 0.0157	1.6 0.0630	13 0.5118	10 0.3937	14.4 0.5669	M16x1.5 5/8-18UNF
A316		80	119 4.6850	102.5 4.0354	25.4 1.0000	31.8 1.2520	2.4 0.0945	0.4 0.0157	2 0.0787	13 0.5118	12 0.4724	14.4 0.5669	M16x1.5
A317-52 317	3-1/4	85	127 5.0000	108.1 4.2559	25.4 1.0000	31.8 1.2520	1.6 0.0630	0.4 0.0157	2 0.0787	13 0.5118	12 0.4724	14.4 0.5669	M16x1.5 5/8-18UNF
A318-56 318	3-1/2	90	133 5.2362	114.6 4.5118	28.6 1.1260	36.5 1.4370	2.4 0.0945	0.4 0.0157	2 0.0787	14.5 0.5709	12 0.4724	18.4 0.7244	M20x1.5 3/4-16UNF
A319 319-60	3-3/4	95	140 5.5118	121.1 4.7677	28.6 1.1260	36.5 1.4370	2.4 0.0945	0.4 0.0157	2 0.0787	14.5 0.5709	12 0.4724	18.4 0.7244	M20x1.5 3/4-16UNF
A320 320-64	4	100	146 5.7480	129.1 5.0827	28.6 1.1260	36.5 1.4370	2.4 0.0945	0.4 0.0157	2.5 0.0984	14.5 0.5709	12 0.4724	18.4 0.7244	M20x1.5 3/4-16UNF

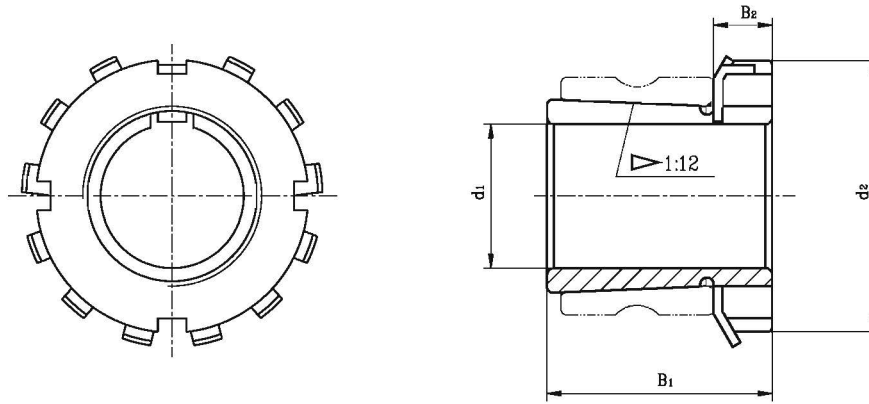

H2300

Adapter No.	Inside Dia.of Sleeve		Dimensions(mm)/(in.)			Sleeve No.	Lockunt No.	Washer No.	Mass (kg)
	d1		B1	d2	B2				
	(in.)	(mm)							
HE2305 H2305	3/4	20	35	38	8	AE2305 A2305	KM05	MB05	0.09
HS2306 HA2306 H2306 HE2306	7/8 15/16 1	25	38	45	8	AS2306 AA2306 A2306 AE2306	KM06	MB06	0.13
HS2307 H2307 HA2307	1-1/8 1-3/16	30	43	52	9	AS2307 A2307 AA2307	KM07	MB07	0.17
HE2308 HS2308 H2308	1-1/4 1-3/8	35	46	58	10	AE2308 AS2308 A2308	KM08	MB08	0.22
HA2309 HE2309 H2309	1-7/16 1-1/2	40	50	65	11	AA2309 AE2309 A2309	KM09	MB09	0.28
HS2310 HA2310 HE2310 H2310	1-5/8 1-11/16 1-3/4	45	55	70	12	AS2310 AA2310 AE2310 A2310	KM10	MB10	0.36
HS2311 HA2311 H2311 HE2311	1-7/8 1-15/16 2	50	59	75	12	AS2311 AA2311 A2311 AE2311	KM11	MB11	0.42
HS2312 H2312	2-1/8	55	62	80	13	AS2312 A2312	KM12	MB12	0.48
HA2313 HE2313 H2313 HS2313	2-3/16 2-1/4 2-3/8	60	65	85	14	AA2313 AE2313 A2313 AS2313	KM13	MB13	0.55
HA2315 HE2315 H2315	2-7/16 2-1/2	65	73	98	15	AA2315 AE2315 A2315	KM15	MB15	1.05
HA2316 HE2316 H2316	2-11/16 2-3/4	70	78	105	17	AA2316 AE2316 A2316	KM16	MB16	1.30
HA2317 H2317 HE2317	2-15/16 3	75	82	110	18	AA2317 A2317 AE2317	KM17	MB17	1.45
H2318		80	86	120	18	A2318	KM18	MB18	1.70
HE2319 H2319	3-1/4	85	90	125	19	AE2319 A2319	KM19	MB19	1.90
HE2320 H2320	3-1/2	90	97	130	20	AE2320 A2320	KM20	MB20	2.15
H2322		100	105	145	21	A2322	KM22	MB22	2.75
H2324		110	112	155	22	A2324	KM24	MB24	3.20
H2326		115	121	165	23	A2326	KM26	MB26	4.60
H2328		125	131	180	24	A2328	KM28	MB28	5.55



## Conversion factors for British and S.I.Units

Quantity	Conversions
Mass	1 lb = 0.4536kg 1 kg = 2.205lb
Force	1 lbf = 4.448N 1 N = 0.2248lbf
Torque	1 lbf.ft = 1.3558N.m 1 lbf.in = 0.1130N.m 1 N.m = 0.7376lbf.ft 1 N.m = 8.8850lbf.in

## Metric-inch conversion table

mm	0	10	20	30	40	50	60	70	80	90
0	inches	0.39370	0.78740	1.18110	1.57480	1.96850	2.36220	2.75591	3.14961	3.54331
1	0.03937	0.43307	0.82677	1.22047	1.61417	2.00787	2.40157	2.79528	3.18898	3.58268
2	0.07874	0.47244	0.86614	1.25984	1.65354	2.04724	2.44094	2.83465	3.22835	3.62205
3	0.11811	0.51181	0.90551	1.29921	1.69291	2.08661	2.48031	2.87402	3.26772	3.66142
4	0.15748	0.55118	0.94488	1.33858	1.73228	2.12598	2.51969	2.91339	3.30709	3.70079
5	0.19685	0.59055	0.98425	1.37795	1.77165	2.16535	2.55906	2.95276	3.34646	3.74016
6	0.23622	0.62992	1.02362	1.41732	1.81102	2.20472	2.59843	2.99213	3.38583	3.77953
7	0.27559	0.66929	1.06299	1.45669	1.85039	2.24409	2.63780	3.03150	3.42520	3.81890
8	0.31496	0.70866	1.10236	1.49606	1.88976	2.28346	2.67717	3.07087	3.46457	3.85827
9	0.35433	0.74803	1.14173	1.53543	1.92913	2.32283	2.71653	3.11024	3.50394	3.89764

mm	0	100	200	300
0	inches	3.93701	7.87402	11.8110
5	0.19685	4.13386	8.07087	12.0079
10	0.39370	4.33071	8.26772	12.2047
15	0.59055	4.52756	8.46457	12.4016
20	0.78740	4.72441	8.66142	12.5984

mm	inches	mm	inches	mm	inches
25	0.98425	4.92126	8.85827	12.7953	
30	1.18110	5.11811	9.05512	12.9921	0.001 0.000039
35	1.37795	8.31496	9.25197	13.1890	0.002 0.000079
40	1.57480	5.51181	9.44882	13.3858	0.003 0.000118
45	1.77165	5.70866	9.64567	13.5827	0.004 0.000157
					0.005 0.000197
50	1.96850	5.90551	9.84252	13.7795	
55	2.16535	6.10236	10.0394	13.9764	0.006 0.000236
60	2.36220	6.29921	10.2362	14.1732	0.007 0.000276
65	2.55906	6.49606	10.4331	14.3701	0.008 0.000315
70	2.75591	6.69291	10.6299	14.5669	0.009 0.000354
75	2.95276	6.88976	10.8268	14.7638	
80	3.14961	7.09661	11.0236	14.9606	
85	3.34646	7.28346	11.2205	15.1575	
90	3.54331	7.48031	11.4173	15.3543	
95	3.74016	7.67716	11.6142	15.5512	





# APPENDICES

## inch-mm Conversion table

1" = 25.4mm

inch		0	1	2	3	4	5	6	7	8	9	10
Fraction	Decimal	mm										
0	0.000000	0.000	25.400	50.800	76.200	101.600	127.000	152.400	177.800	203.200	228.600	254.000
1/64	0.015625	0.397	25.797	51.197	76.597	101.997	127.397	152.797	178.197	203.597	228.997	254.397
1/32	0.031250	0.794	26.194	51.594	76.994	102.394	127.794	153.194	178.594	203.994	229.394	254.794
3/64	0.046875	1.191	26.591	51.991	77.391	102.791	128.191	153.591	178.991	204.391	229.791	255.191
1/16	0.062500	1.588	26.988	52.388	77.788	103.188	128.588	153.988	179.388	204.788	230.188	255.588
5/64	0.078125	1.984	27.384	52.784	78.184	103.584	128.984	154.384	179.784	205.184	230.584	255.984
3/32	0.093750	2.381	27.781	53.181	78.581	103.981	129.381	154.781	180.181	205.581	230.981	256.381
7/64	0.109375	2.778	28.178	53.578	78.978	104.378	129.778	155.178	180.578	205.978	231.378	256.778
1/8	0.125000	3.175	28.575	53.975	79.375	104.775	130.175	155.575	180.975	206.375	231.775	257.175
9/64	0.140625	3.572	28.972	54.372	79.772	105.172	130.572	155.972	181.372	206.772	232.172	257.572
5/32	0.156250	3.969	29.369	54.769	80.169	105.569	130.969	156.369	181.769	207.169	232.569	257.969
11/64	0.171875	4.366	29.766	55.166	80.566	105.966	131.366	156.766	182.166	207.566	232.966	258.366
3/16	0.187500	4.762	30.163	55.563	80.963	106.363	131.763	157.163	182.563	207.963	233.363	258.763
13/64	0.203125	5.159	30.559	55.959	81.359	106.759	132.159	157.559	182.959	208.359	233.759	259.159
7/32	0.218750	5.556	30.956	56.356	81.756	107.156	132.556	157.956	183.356	208.756	234.156	259.556
15/64	0.234375	5.953	31.353	56.753	82.153	107.553	132.953	158.353	183.753	209.153	234.553	259.953
1/4	0.250000	6.350	31.750	57.150	82.550	107.950	133.350	158.750	184.150	209.550	234.950	260.350
17/64	0.265625	6.747	32.147	57.547	82.947	108.347	133.747	159.147	184.547	209.947	235.347	260.747
9/32	0.281250	7.144	32.544	57.944	83.344	108.744	134.144	159.544	184.944	210.344	235.744	261.144
19/64	0.296875	7.541	32.941	58.341	83.741	109.141	134.541	159.941	185.341	210.741	236.141	261.541
5/16	0.312500	7.938	33.338	58.738	84.138	109.538	134.938	160.338	185.738	211.138	236.538	261.938
21/64	0.328125	8.334	33.734	59.134	84.534	109.934	135.334	160.734	186.134	211.534	236.934	262.334
11/32	0.343750	8.731	34.131	59.531	84.931	110.331	135.731	161.131	186.531	211.931	237.331	262.731
23/64	0.359375	9.128	34.528	59.928	85.328	110.728	136.128	161.528	186.928	212.328	237.728	263.128
3/8	0.375000	9.525	34.925	60.325	85.725	111.125	136.525	161.925	187.325	212.725	238.125	263.525
25/64	0.390625	9.922	35.322	60.722	86.122	111.522	136.922	162.322	187.722	213.122	238.522	263.922
13/32	0.406250	10.319	35.719	61.119	86.519	111.919	137.319	162.719	188.119	213.519	238.919	264.319
27/64	0.421875	10.716	36.116	61.516	86.916	112.316	137.716	163.116	188.516	213.916	239.316	264.716
7/16	0.437500	11.113	36.513	61.913	87.313	112.713	138.113	163.513	188.913	214.313	239.713	265.113
29/64	0.453125	11.509	36.909	62.309	87.709	113.109	138.509	163.909	189.309	214.709	240.109	265.509
15/32	0.468750	11.906	37.306	62.706	88.106	113.506	138.906	164.306	189.706	215.106	240.506	265.906
31/64	0.484375	12.303	37.703	63.103	88.503	113.903	139.303	164.703	190.103	215.503	240.903	266.303
1/2	0.500000	12.700	38.100	63.500	88.900	114.300	139.700	165.100	190.500	215.900	241.300	266.700
33/64	0.515625	13.097	38.497	63.897	89.297	114.697	140.097	165.497	190.897	216.297	241.697	267.097
17/32	0.531250	13.494	38.894	64.294	89.694	115.094	140.494	165.894	191.294	216.694	242.094	267.494
35/64	0.546875	13.891	39.291	64.691	90.091	115.491	140.891	166.291	191.691	217.091	242.491	267.891
9/16	0.562500	14.288	39.688	65.088	90.488	115.888	141.288	166.688	192.088	217.488	242.888	268.288
37/64	0.578125	14.684	40.084	65.484	90.884	116.284	141.684	167.084	192.484	217.884	243.284	268.684
19/32	0.593750	15.081	40.481	65.881	91.281	116.681	142.081	167.481	192.881	218.281	243.681	269.081
39/64	0.609375	15.478	40.878	66.278	91.678	117.078	142.478	167.878	193.278	218.678	244.078	269.478
5/8	0.625000	15.875	41.275	66.675	92.075	117.475	142.875	168.275	193.675	219.075	244.475	269.875
41/64	0.640625	16.272	41.672	67.072	92.472	117.872	143.272	168.672	194.072	219.472	244.872	270.272
21/32	0.656250	16.669	42.069	67.469	92.869	118.269	143.669	169.069	194.469	219.869	245.269	270.669
43/64	0.671875	17.066	42.466	67.866	93.266	118.666	144.066	169.466	194.866	220.266	245.666	271.066
11/16	0.687500	17.463	42.863	68.263	93.663	119.063	144.463	169.863	195.263	220.663	246.063	271.463
45/64	0.703125	17.859	43.259	68.659	94.059	119.459	144.859	170.259	195.659	221.059	246.459	271.859
23/32	0.718750	18.256	43.656	69.056	94.456	119.856	145.256	170.656	196.056	221.456	246.856	272.256
47/64	0.734375	18.653	44.053	69.453	94.853	120.253	145.653	171.053	196.453	221.853	247.253	272.653
3/4	0.750000	19.050	44.450	69.850	95.250	120.650	146.050	171.450	196.850	222.250	247.650	273.050
49/64	0.765625	19.447	44.847	70.247	95.647	121.047	146.447	171.847	197.247	222.647	248.047	273.447
25/32	0.781250	19.844	45.244	70.644	96.044	121.444	146.844	172.244	197.644	223.044	248.444	273.844
51/64	0.796875	20.241	45.641	71.041	96.441	121.841	147.241	172.641	198.041	223.441	248.841	274.241
13/16	0.812500	20.638	46.038	71.438	96.838	122.238	147.638	173.038	198.438	223.838	249.238	274.638
53/64	0.828125	21.034	46.434	71.834	97.234	122.634	148.034	173.434	198.834	224.234	249.634	275.034
27/32	0.843750	21.431	46.831	72.231	97.631	123.031	148.431	173.831	199.231	224.631	250.031	275.431
55/64	0.859375	21.828	47.228	72.628	98.028	123.428	148.828	174.228	199.628	225.028	250.428	275.828
7/8	0.875000	22.225	47.625	73.025	98.425	123.825	149.225	174.625	200.025	225.425	250.825	276.225
57/64	0.890625	22.622	48.022	73.422	98.822	124.222	149.622	175.022	200.422	225.822	251.222	276.622
29/32	0.906250	23.019	48.419	73.819	99.219	124.619	150.019	175.419	200.819	226.219	251.619	277.019
59/64	0.921875	23.416	48.816	74.216	99.616	125.016	150.416	175.816	201.216	226.616	252.016	277.416
15/16	0.937500	23.813	49.213	74.613	100.013	125.413	150.813	176.213	201.613	227.013	252.413	277.813
61/64	0.953125	24.209	49.609	75.009	100.409	125.809	151.209	176.609	202.009	227.409	252.809	278.209
31/32	0.968750	24.606	50.006	75.406	100.806	126.206	151.606	177.006	202.406	227.806	253.206	278.606
63/64	0.984375	25.003	50.403	75.803	101.203	126.603	152.003	177.403	202.803	228.203	253.603	279.003



# APPENDICES

Temperature conversion table

$$C = \frac{5}{9}(F-32)$$

$$F = 32 + \frac{9}{5}C$$

°C		°F	°C		°F	°C		°F	°C		°F
-73.3	-100	-148.0	0.0	32	89.6	21.7	71	159.8	43.3	110	230
-62.2	-80	-112.0	0.6	33	91.4	22.2	72	161.6	46.1	115	239
-51.1	-60	-76.0	1.1	34	93.2	22.8	73	163.4	48.9	120	248
-40.0	-40	-40.0	1.7	35	95.0	23.3	74	165.2	51.7	125	257
-34.4	-30	-22.0	2.2	36	96.8	23.9	75	167.0	54.4	130	266
-28.9	-20	-4.0	2.8	37	98.6	24.4	76	168.8	57.2	135	275
-23.3	-10	14.0	3.3	38	100.4	25.0	77	170.6	60.0	140	284
-17.8	0	32.0	3.9	39	102.2	25.6	78	172.4	65.6	150	302
-17.2	1	33.8	4.4	40	104.0	26.1	79	174.2	71.1	160	320
-16.7	2	35.6	5.0	41	105.8	26.7	80	176.0	76.7	170	338
-16.1	3	37.4	5.6	42	107.6	27.2	81	177.8	82.2	180	356
-15.6	4	39.2	6.1	43	109.4	27.8	82	179.6	87.8	190	374
-15.0	5	41.0	6.7	44	111.2	28.3	83	181.4	93.3	200	392
-14.4	6	42.8	7.2	45	113.0	28.9	84	183.2	98.9	210	410
-13.9	7	44.6	7.8	46	114.8	29.4	85	185.0	104.4	220	428
-13.3	8	46.4	8.3	47	116.6	30.0	86	186.8	110.0	230	446
-12.8	9	48.2	8.9	48	118.4	30.6	87	188.6	115.6	240	464
-12.2	10	50.0	9.4	49	120.2	31.1	88	190.4	121.1	250	482
-11.7	11	51.8	10.0	50	122.0	31.7	89	192.2	148.9	300	572
-11.1	12	53.6	10.6	51	123.8	32.2	90	194.0	176.7	350	662
-10.6	13	55.4	11.1	52	125.6	32.8	91	195.8	204	400	752
-10.0	14	57.2	11.7	53	127.4	33.3	92	197.6	232	450	842
-9.4	15	59.0	12.2	54	129.2	33.9	93	199.4	260	500	932
-8.9	16	60.8	12.8	55	131.0	34.4	94	201.2	288	550	1022
-8.3	17	62.6	13.3	56	132.8	35.0	95	203.0	316	600	1112
-7.8	18	64.4	13.9	57	134.6	35.6	96	204.8	343	650	1202
-7.2	19	66.2	14.4	58	136.4	36.1	97	206.6	371	700	1292
-6.7	20	68.0	15.0	59	138.2	36.7	98	208.4	399	750	1382
-6.1	21	69.8	15.6	60	140.0	37.2	99	210.2	427	800	1472
-5.6	22	71.6	16.1	61	141.8	37.8	100	212.0	454	850	1562
-5.0	23	73.4	16.7	62	143.6	38.3	101	213.8	482	900	1652
-4.4	24	75.2	17.2	63	145.4	38.9	102	215.6	510	950	1742
-3.9	25	77.0	17.8	64	147.2	39.4	103	217.4	538	1 000	1832
-3.3	26	78.8	18.3	65	149.0	40.0	104	219.2	593	1 100	2012
-2.8	27	80.6	18.9	66	150.8	40.6	105	221.0	649	1 200	2192
-2.2	28	82.4	19.4	67	152.6	41.1	106	222.8	704	1 300	2372
-1.7	29	84.2	20.0	68	154.4	41.7	107	224.6	760	1 400	2552
-1.1	30	86.0	20.6	69	156.2	42.2	108	226.4	816	1 500	2732
-0.6	31	87.8	21.1	70	158.0	42.8	109	228.2	871	1 600	2912

(Method of using this table) for example, to convert 38° C into °F, read the figure in the right °F column adjacent to the 38 in the center column in the 2nd block. This means that 38° C is 100.4 °F. To convert 38 °F into °C, read the figure in the left °C column of the same row, which indicates that the answer is 3.3 °C.

## Kgf-N Conversion table

1 kgf = 9.80665 N  
1 N = 0.101972 kgf

kgf		N	kgf		N	kgf		N
0.1020	1	9.8066	3.4670	34	333.43	6.8321	67	657.04
0.2039	2	19.613	3.5690	35	343.23	6.9341	68	666.85
0.3059	3	29.420	3.6710	36	353.04	7.0361	69	676.66
0.4079	4	39.227	3.7730	37	362.85	7.1380	70	686.46
0.5099	5	49.033	3.8749	38	372.65	7.2400	71	696.27
0.6118	6	58.840	3.9769	39	382.46	7.3420	72	706.08
0.7138	7	68.646	4.0789	40	392.27	7.4440	73	715.88
0.8158	8	78.453	4.1808	41	402.07	7.5459	74	725.69
0.9177	9	88.260	4.2828	42	411.88	7.6479	75	735.50
1.0197	10	98.066	4.3848	43	421.68	7.7499	76	745.30
1.1217	11	107.87	4.4868	44	431.49	7.8518	77	755.11
1.2237	12	117.68	4.5887	45	441.30	7.9538	78	764.92
1.3256	13	127.49	4.6907	46	451.10	8.0558	79	774.72
1.4276	14	137.29	4.7927	47	460.91	8.1578	80	784.53
1.5296	15	147.10	4.8946	48	470.72	8.2597	81	794.34
1.6316	16	156.91	4.9966	49	480.52	8.3617	82	804.14
1.7335	17	166.71	5.0986	50	490.33	8.4637	83	813.95
1.8355	18	176.52	5.2006	51	500.14	8.5656	84	823.76
1.9375	19	186.33	5.3025	52	509.94	8.6676	85	833.56
2.0394	20	196.13	5.4045	53	519.75	8.7696	86	843.37
2.1414	21	205.94	5.5065	54	529.56	8.8716	87	853.18
2.2434	22	215.75	5.6085	55	539.36	8.9735	88	862.98
2.3454	23	225.55	5.7104	56	549.17	9.0755	89	872.79
2.4473	24	235.36	5.8124	57	558.98	9.1775	90	882.60
2.5493	25	245.17	5.9144	58	568.78	9.2794	91	892.40
2.6513	26	254.97	6.0163	59	578.59	9.3814	92	902.21
2.7532	27	264.78	6.1183	60	588.40	9.4834	93	912.02
2.8552	28	274.59	6.2203	61	598.20	9.5854	94	921.82
2.9572	29	284.39	6.3223	62	608.01	9.6873	95	931.63
3.0592	30	294.20	6.4242	63	617.82	9.7893	96	941.44
3.1611	31	304.01	6.5262	64	627.62	9.8913	97	951.24
3.2631	32	313.81	6.6282	65	637.43	9.9932	98	961.05
3.3651	33	323.62	6.7302	66	647.24	10.0952	99	970.86

(Method of using this table) for example, If you wish to convert 10 kgf to N's, locate unit 10 in the center column. Opposite in the N column is the answer, 10kgf equals ,98.066 N. To convert 10 N to kgfs follow the same procedure, 10 N equals 1. 0197kgf.











# APPENDICES













### Kg-lb Conversion table

1 kg = 2.2046226 lb  
1 lb = 0.45359237 kg

kg		lb	kg		lb	kg		lb
0.454	1	2.205	15.422	34	74.957	30.391	67	147.71
0.907	2	4.409	15.876	35	77.162	30.844	68	149.91
1.361	3	6.614	16.329	36	79.366	31.298	69	152.12
1.814	4	8.818	16.783	37	81.571	31.751	70	154.32
2.268	5	11.203	17.237	38	83.776	32.205	71	156.53
2.722	6	13.228	17.690	39	85.980	32.659	72	158.73
3.175	7	15.432	18.144	40	88.185	33.112	73	160.94
3.629	8	17.637	18.597	41	90.390	33.566	74	163.14
4.082	9	19.842	19.051	42	92.594	34.019	75	165.35
4.536	10	22.046	19.504	43	94.799	34.473	76	167.55
4.990	11	24.251	19.958	44	97.003	34.927	77	169.76
5.443	12	26.455	20.412	45	99.208	35.380	78	171.96
5.897	13	28.660	20.865	46	101.41	35.834	79	174.17
6.350	14	30.865	21.319	47	103.62	36.287	80	176.37
6.804	15	33.069	21.772	48	105.82	36.741	81	178.57
7.257	16	35.274	22.226	49	108.03	37.195	82	180.78
7.711	17	37.479	22.680	50	110.23	37.648	83	182.98
8.165	18	39.683	23.133	51	112.44	38.102	84	185.19
8.618	19	41.888	23.587	52	114.64	38.555	85	187.39
9.072	20	44.092	24.040	53	116.84	39.009	86	189.60
9.525	21	46.297	24.494	54	119.05	39.463	87	191.80
9.979	22	48.502	24.948	55	121.25	39.916	88	194.01
10.433	23	50.706	25.401	56	123.46	40.370	89	196.21
10.886	24	52.911	25.855	57	125.66	40.823	90	198.42
11.340	25	55.116	26.308	58	127.87	41.277	91	200.62
11.793	26	57.320	26.762	59	130.07	41.730	92	202.83
12.247	27	59.525	27.216	60	132.28	42.184	93	205.03
12.701	28	61.729	27.669	61	134.48	42.638	94	207.23
13.154	29	63.934	28.123	62	136.69	43.091	95	209.44
13.608	30	66.139	28.576	63	138.89	43.545	96	211.64
14.061	31	68.343	29.030	64	141.10	43.998	97	213.85
14.515	32	70.548	29.484	65	143.30	44.452	98	216.05
14.969	33	72.753	29.937	66	145.51	44.906	99	218.26

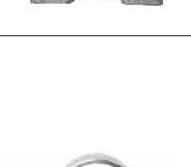



(Method of using this table) For example, to convert 10kg into lb, read the figure in the right lb column adjacent to the 10 in the center column in the 1st block. This means that 10kg is 22.046 lb. To convert 10lb into kg, read the figure in the left kg column of the same row, which indicates that the answer is 4.536kg.

							
	TR	UC	NA	UK	SA	SB	
	GB	UC	UEL	UK	UE	UB	
	NTN	UC..D1	UEL..D1W3	UK..D1	AEL..W3	AS	
	FYH	UC	NA	UK	SA	SB	
	NSK	UC	EW	UK	EN	UB	
	ASAHI	UC	UG..+ER	UK	KH..+ER	B	
	INA	G(N)YE..KRRB	G(N)E..KRRB		RAE..NPPB	AY..NPPB	
	SKF	YAR..2F	YEL..2F		YET		
	RHP	10..G	10..DECG	10..KG	12..EC	12	
PEER	UC	HC		FH	FHS		
	P2	TR	UCP2	NAP2	UKP2+H	SAP2	SBP2
	P2	GB	UCP2	UEL2	UKP2+H		
	P2..D1	NTN	UCP2..D1	UEL2..D1W3	UKP2..D1;H		
	P2	FYH	UCP2	NAP2	UKP2		
	P2	NSK	UCP2	EWP2	UKP2+H		UBP2..JG00
	P2	ASAHI	UCP2		UKP2+H		BP2
	ASE	INA	RASEY	RASE		PASE	PASEY
	SY	SKF	SY..TF	SY..WF		SY..FM	
	NP	RHP	NP	NP..DEC	NP10..K	NP..EC	NP..A
	P2	PEER	UCP2	HCP2	UKP2+H	FHP2	FHSP2
	PX	TR	UCPX				
	PX..D1	NTN	UCPX..D1				
	PX	FYH	UCPX				
	PX	ASAHI	UCPX				
	MP	RHP	MP				
	PX	PEER	UCPX				
	P3	TR	UCP3	NAP3	UKP3+H		
	P3	GB	UCP3	UEL3	UKP3+H		
	P3..D1	NTN	UCP3..D1	UEL3..D1W3	UKP3..D1;H		
	P3	FYH	UCP3		UKP3		
	P3	NSK	UCP3	EWP3	UKP3+H		
	P3	ASAHI	UCP3		UKP3+H		
	SAO	INA	RSAOY	RSAO			
	PK2	TR	UCPK2	NAPK2			
	PL2..D1	NTN	UCPL2..D1	UELPL2..D1W3			
	SL	FYH	SL2				
	PK2	NSK	UCPK2				
	LP2	ASAHI	UCLP2				
	SL	RHP	SL	SL..DEC			
	LP2	PEER	UCLP2	HCLP2			

							
	LP2	TR				SALP2	SBLP2
	LP2	FYH				ALP2	BLP2
	LP2	NSK				ENLP2	UBLP2
	LLP2	ASAHI					BLLP2
	PWC2	PEER				FHPWC2	FHSPWC2
	PH2	TR	UCPH2				
	PH2	GB	UCPH2				
	HP2..D1	NTN	UCHP2..D1				
	PH2	FYH	UCPH2				
	PH2	NSK	UCPH2				
	PH2	ASAHI	UCPH2				
	PA2	TR	UCPA2				
	PA2	GB	UCPA2				
	UP2..D1	NTN	UCUP2..D1				
	PA2	FYH	UCPA2				
	PA2	NSK	UCPA2				
	PA2	ASAHI	UCPA2				
	PA2	PEER	UCPA2				
	PA2..A	TR	UCPA2..A				
	SHE	INA	RSHEY				
	SYF	SKF	SYF..TF				
	SNP	RHP	SNP				
	PAS2	PEER	UCPAS2				
	PP2	TR				SAPP2	SBPP2
	PP2	GB				UEPP2	UBPP2
	PP2	NTN				AELPP2..W3	ASPP2
	PP2..F	FYH				SAPP2..F	SBPP2..F
	PP2	NSK				ENPP2	UBPP2
	PP2	ASAHI					BPP2
	GEH..BT	INA				PB	PBY
	P	SKF				P..FM	
	LPB	RHP				LPB..EC	LPB..A
	PP..Z-IL					FHPPZ..IL	FHSPPZ..IL
	F2	TR	UCF2	NAF2	UKF2+H	SAF2..G	SBF2
	F2..D1	NTN	UCF2..D1	UELF2..D1W3	UKF2..D1;H		
	F2	FYH	UCF2		UKF2		
	F2	NSK	UCF2	EWf2	UKF2+H		UBF2..JG00
	F2	ASAHI	UCF2		UKF2+H		BF2
	F2	PEER	UCF2			FHF2	FHSF2
	FX	TR	UCFX				
	FX..D1	NTN	UCFX..D1				
	FX	FYH	UCFX				
	FX	ASAHI	UCFX				
	MSF	RHP	MSF				
	F2	PEER	UCFX				



# A TABLE OF MOUNTED UNITS REFERENCES

							
	F3	TR	UCF3	NAF3	UKF3+H		
	FU3	GB	UCFU3	UELFU3	UKFU3+H		
	F3..D1	NTN	UCF3..D1	UELF3..D1W3	UKF3..D1;H		
	F3	FYH	UCF3		UKF3		
	F3	NSK	UCF3	EWF3	UKF3+H		
	F3	ASAHI	UCF3		UKF3+H		
	CJO	INA	RCJOY	RCJO			
	FU2	TR	UCFU2	NAFU2	(UKFU2+H)	SAFU2	(SBFU2)
	FU2	GB	UCFU2	UELFU2	UKFU2+H		
	FU2..D1	NTN		UELFU2..D1W3			
	NF2	FYH		NANF2			
	CJ	INA	RCJY	RCJ		PCJ	PCJY
	FY	SKF	FY..TF	FY..WM		FY..FM	
	SF	RHP	SF	SF..DEC	MSF..K	SF..EC	SF..A
	FS2	PEER		HCFS2			
	FS3	TR	UCFS3	NAFS3	UKFS3+H		
	FS3..D1	NTN	UCFS3..D1	UELFS3..D1W3	UKFS3..D1;H		
	FS3	FYH	UCFS3				
	FS3	NSK	UCFS3		UKFS3+H		
	FS3	ASAHI	UCFS3				
	FL2	TR	UCFL2	NAFL2	UKFL2+H	SAFL2	SBFL2
	FL2..D1	NTN	UCFL2..D1	UELFLU2..D1W3	UKFL2..D1;H		
	FL2	FYH	UCFL2		UKFL2		
	FL2	NSK	UCFL2	EWFL2	UKFL2+H		UBFL2..JG00
	FL2	ASAHI	UCFL2				BFL2
	FT2	PEER	UCFT2			FHFT2	FHSFT2
	FLX	TR	UCFLX				
	FLX..D1	NTN	UCFLX..D1				
	FLX	FYH	UCFLX				
	FLX	ASAHI	UCFLX				
	MSFT	RHP	MSFT				
	FTX	PEER	UCFTX				
	FL3	TR	UCFL3	NAFL3	UKFL3+H		
	FLU3	GB	UCFLU3	UELFLU3	UKFLU3+H		
	FL3..D1	NTN	UCFL3..D1	UELFL3..D1W3	UKFL3..D1;H		
	FL3	FYH	UCFL3		UKFL3		
	FL3	NSK	UCFL3	EWFL3	UKFL3+H		
	FL3	ASAHI	UCFL3				













# A TABLE OF MOUNTED UNITS REFERENCES

							
	FLU2	TR	UCFLU2	NAFLU2	(UKFLU2+H)	SAFLU2	(SBFLU2)
	FLU2	GB	UCFLU2	UELFLU2	UKFLU2+H		
	FLU2..D1	NTN		UELFLU2..D1W3			
	NFL2	FYH		NANFL2			
	CJT	INA	RCJTY	RCJT		PCJT	PCJTY
	FYTB	SKF	FYTB..TF	FYTB..WF		FYTB..FM	
	SFT	RHP	SFT	SFT..DEC	MSFT..K	SFT..EC	SFT..A
	FTS2	PEER		HCFTS2			
	LF2	TR				SALF2	SBLF2
	LF2	FYH				ALF2	BLF2
	LF2..BJ	NSK				ENLF2..BJ	UBLF2..BJ
	LF2	PEER				FHLF2	FHSLF2
	LFTC	TR				SALFTC2	SBLFTC2
	LCTE..K	ASAHI					BLCTE2..K
	LCTE	INA				FLCTE	FLCTEY
	LFTC	RHP				LFTC..EC	LFTC..A
	FD2	TR				SAFD2	SBFD2
	FD2	NTN				AELFD2..W3	ASFD2
	FD2	PEER				FHFD2	FHSFD2
		-					
	PFTD2	TR				SAPFTD2	SBPFTD2
	FX2	PEER				FHFX2	FHSFX2
		-					
	FCT2	TR				SAFCT2	SBFCT2
	F3X2	PEER				FHF3X2	FHSF3X2
		-					
		-					
	PFL2	TR				SAPFL2	SBPFL2
	PFL2	GB				UEPFL2	UBPFL2
	PFL2	NTN				ABLPFL2..W3	ASPFL2
	PFL2	FYH				SAPFL2	SBPFL2
	PFL2	NSK				ENPFL2	UBPFL2
	PFL2	ASAHI					BPFL2
	PLAN..MSB	INA				RAT	RATY
	PFT	SKF				PFT..FM	
	SLFL	RHP				SLFL..EC	SLFL..A
	PFL..R	PEER				FHPFLR2	FHSPFLR2
	FC2	TR	UCFC2	NAFC2	UKFC2+H		
	FC2	GB	UCFC2	UELFC2	UKFC2+H		
	FC2..D1	NTN	UCFC2..D1	UELFC2..D1W3	UKFC2..D1;H		
	FC2	FYH	UCFC2	NAFC2	UKFC2		
	FC2	NSK	UCFC2	EWFC2	UKFC2+H		
	FC2	ASAHI	UCFC2				
	FC2	PEER	UCFC2				





# A TABLE OF MOUNTED UNITS REFERENCES

							
	PF2	TR				SAPF2	SBPF2
	PF2	GB				UEPF2	UBPF2
	PF2	NTN				AELPF2..W3	ASPF2
	PF2	FYH					SBPF2
	PF2	NSK				ENPF2	UBPF2
	PF2	ASAHI				KHPF2	BPF2
	FLAN..MSB	INA				RA	RAY
	PF	SKF				PF..FM	PF..RM
	SLFE	RHP				SLFE..EC	SLFE..A
	PF..R	PEER				FHPFR2	FHSPFR2
	PFT2	TR				SAPFT2	SBPFT2
	PFT2	GB				UEPFT2	UBPFT2
	PFT2	ASAHI					BPFT2
	FLAN..MSTR	INA				RATR	RATRY
	PF2	SKF				PF2..FM	
	SLFT	RHP				SLFT..EC	SLFT..A
	PFT..Z	PEER				FHPFTZ2	
	T2	TR	UCT2	NAT2			
	T2..D1	NTN	UCT2..D1	UELT2..D1W3			
	T2	FYH	UCT2	NAT2			
	T2	NSK	UCT2	EWT2			
	T2	ASAHI	UCT2				
	TUE	INA	RTUEY	RTUE			
	ST2	TR	UCST2				
	K2	GB	UCK2				
	ST2	ASAHI	UCST2				
	TU	SKF	TU..TF				
	ST	RHP	ST				
	T2	PEER	UCT2				
	C2	TR	UCC2				
	C2	GB	UCC2				
	C2..D1	NTN	UCC2..D1				
	C2	FYH	UCC2				
	C2	NSK	UCC2				
	C2	ASAHI	UCC2				
	SLC	RHP	SLC				
	C2	PEER	UCC2				
	FB2	TR	UCFB2				
	FB2	GB	UCFB2				
	FH2..D1	NTN	UCFH2..D1				
	FB2	FYH	UCFB2				
	FK2	NSK	UCFK2				
	FK2	ASAHI	UCFK2				
	FB2	PEER	UCFB2				

							
	FA2	TR	UCFA2				
	FA2	GB	UCFA2				
	FA2..D1	NTN	UCFA2..D1				
	FA2	FYH	UCFA2				
	FA2	NSK	UCFA2				
	FA2	ASAHI	UCFA2				
	HA2	TR	UCHA2				
	HA2	GB	UCHA2				
	HB2..D1	NTN	UCHB2..D1				
	HA2	FYH	UCHA2				
	EH2	NSK	UCEH2				
	ECH2	ASAHI	UCECH2				
	SCHB	RHP	SCHB				
	HA2	PEER	UCHA2				